

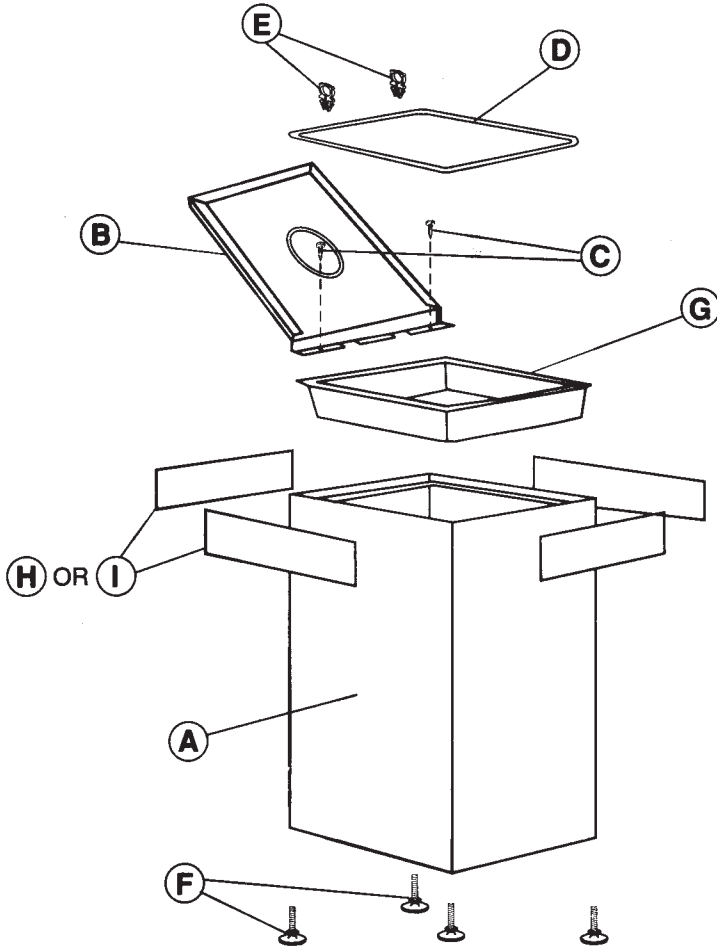

Public Square® Recycling Containers

Container: Models 2981GN, 2982BR, 2983BG, 2984BR
 Lid and Hardware Kit: Models 2987BL, 2988BL, 2989BL

Des. Pat. No. D332,681



Letter Code	A CONTAINER (one only)*		
Model Number	DESCRIPTION		
1002981	26" Base only, Green		
1002982	32" Base only, Brown		
1002983	38" Base only, Burgundy		
1002984	44" Base only, Brown		

* Each of the above Containers includes the following parts packed inside:

G	Plastic Tray	1	Z50719A6
---	--------------	---	----------

LID AND HARDWARE KITS

LETTER CODE	DESCRIPTION	QTY.	PART NO.
B	Black Lid w/2" wide slot	1	F72613A3
C	Screw	2	Z10310A3
D	Wire Hold-Down Ring	1	F52920A3
E	Plastic Clip	2	Z10425A5
F	Leveling Glide	4	Z30227A3
H	Label Set, 4 "Paper"	1	Z40736A6
I	Label Set, 4 "Newspaper"	1	Z40879A3

LETTER CODE	DESCRIPTION	QTY.	PART NO.
B	Black Lid w/4" round hole	1	F72615A1
C	Screw	2	Z10310A3
D	Wire Hold-Down Ring	1	F52920A3
E	Plastic Clip	2	Z10425A5
F	Leveling Glide	4	Z30227A3
H	Label Set, 4 "Cans"	1	Z40735A7
I	Label Set, 4 "Glass"	1	Z40734A8

LETTER CODE	DESCRIPTION	QTY.	PART NO.
B	Black Lid w/8" square opening	1	F72614A2
C	Screw	2	Z10310A3
D	Wire Hold-Down Ring	1	F52920A3
E	Plastic Clip	2	Z10425A5
F	Leveling Glide	4	Z30227A3
H	Label Set, 4 "Waste"	1	Z40733A9
I	Label Set, 4 "Plastic"	1	Z40880A0

TOOLS REQUIRED



PHILLIPS SCREWDRIVER

1 Select your preferred set of labels from the two sets supplied (**H** or **I**). Carefully remove the center strip of backing material from a label. Grasp label as shown and line up with top edge of **A** Container so that ends of label overhang container sides equally. Press down at center of label, peel the backing off one side of the label, and smooth out toward one end, pushing out any air bubbles for a smooth finish. Repeat for the other end; then apply the rest of the labels from this set to each remaining side in the same manner.

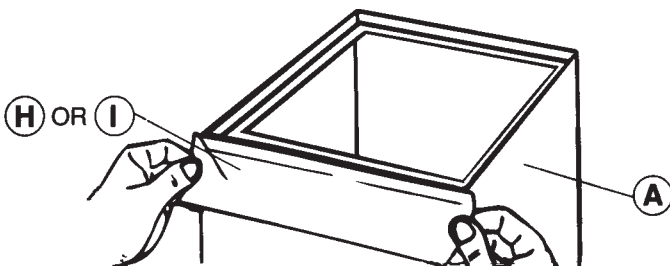

2 Thread four **F** Leveling Glides into the holes in the bottom of **A** Container. Turn the container upright and adjust glides until the container sits level without rocking.

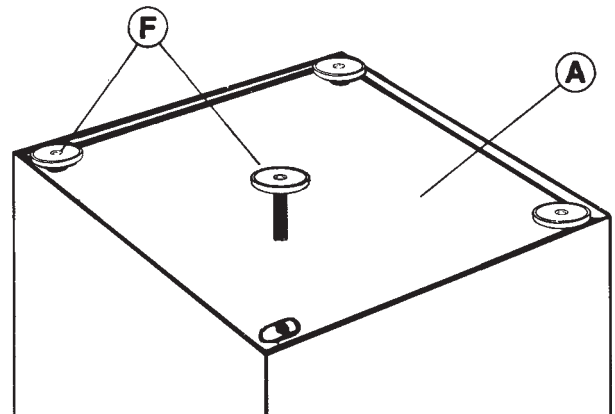

- 3** Line up set of holes in hinged flange of **B** Lid with outer set of holes in inside rim of **A** Container. Fasten with two **C** Screws.

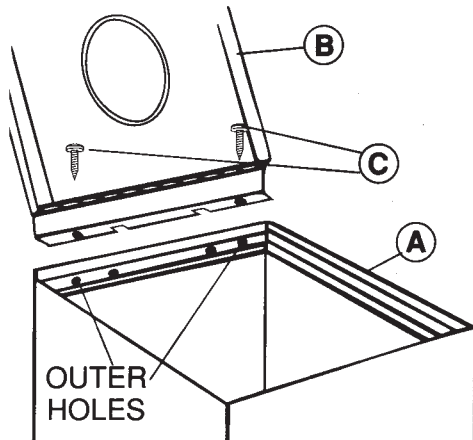

- 4** Slip two **E** Plastic Clips over the wire on welded side of **D** Wire Hold-Down Ring. Align clips with inner holes on inside rim flange, and press points of clips firmly into the holes.

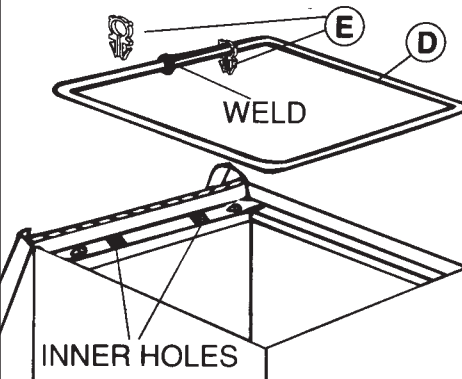

- 5** Insert **G** Plastic Tray into bottom of container to catch occasional drips or leaks.

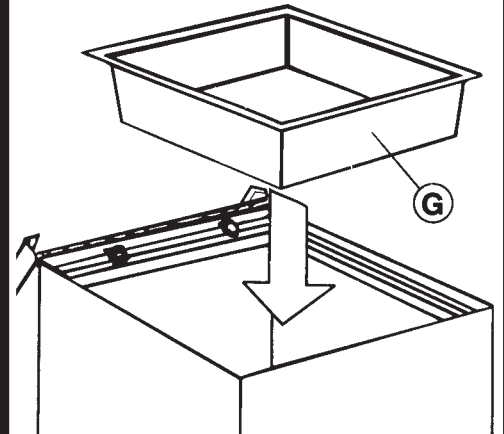

TO INSERT PLASTIC BAGS:

- 6** Open lid, lift wire hold-down ring. Insert bag into opening and fold top edge of bag over three sides of container (not wire/clip side)

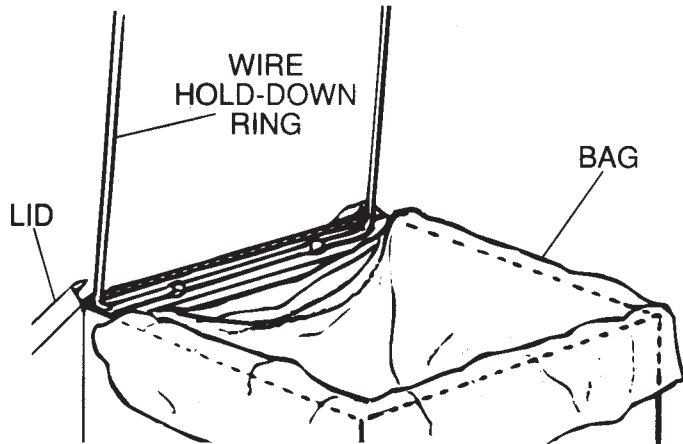

- 7** Pull two back corners of bag under corners of wire hold-down ring until bag is next to the plastic clips.

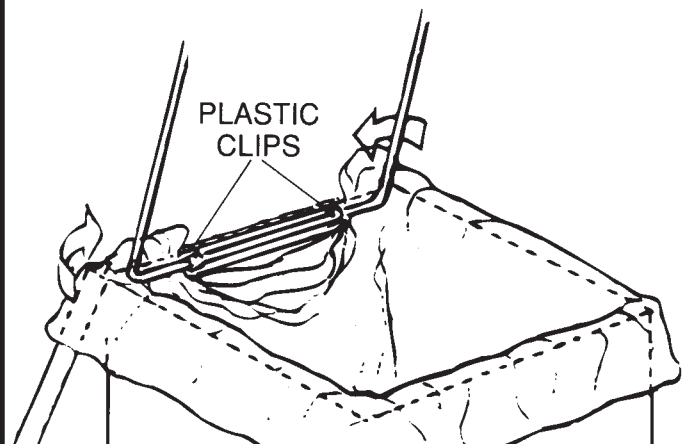

- 8** Lower wire hold-down ring into place, tuck all bag flaps neatly into inside of container (over the wire), and close the lid.

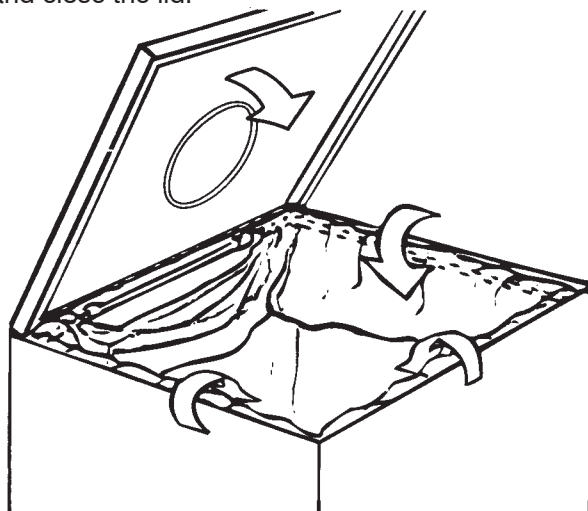

For questions or concerns, please call
Safco Consumer Hot Line 1-800-664-0042
 available Monday-Friday 7:30 AM to 5:00 PM
 (Central Time)
 (English-speaking operators)