

ASSEMBLY INSTRUCTIONS

Mercado Mid-Back Chair

Model No. 2547

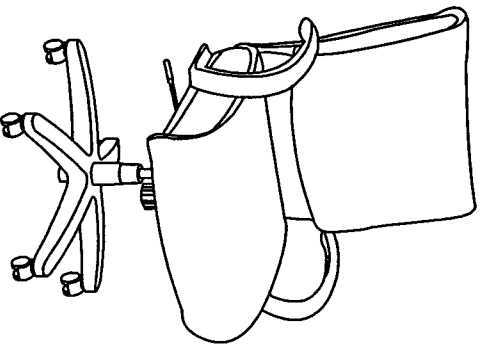

PARTS LIST 2547

When ordering components, specific color and/or size information may be required. Contact a Mayline Customer Service Representative. 1-800-822-8037

* Individual Items, Order by part number.
** Denotes Color Code.

Reference Letter	Quantity
A* 101708 Mechanism	1
B* 101713** Seat	2
C* 101714 Arms (pair)	5
D* 101400 Caster (5 per pack)	1
E* 2547SB Base	1
F* 2547GC Cylinder	1
F* 101715 Cylinder Cover	1

Part Number *	Quantity	Spare
101703 Hardware Bag		
G Screw 1/4-20 x 1"	4	1
H Screw 1/4-20 x 1-1/4"	2	1
J Allen Wrench	1	

1

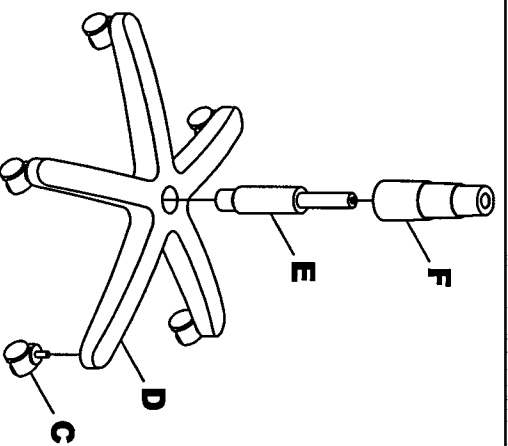

1. Place Base (D) upside down and push Casters (C) firmly into base. 5 places.
2. Turn Base right side up and Insert Cylinder (E) into center hole of Base.
3. Place Cylinder Cover (F) over Cylinder.

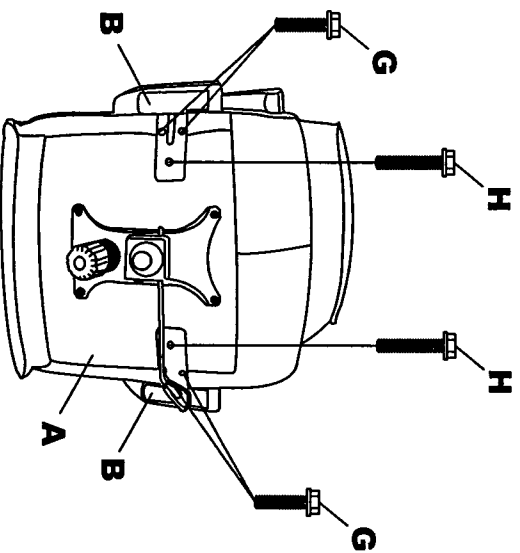

4. Assemble Arms (B) 2 places onto Seat (A) using Screws (H) 1 place each arm & Screws (G) 2 places each arm.

2

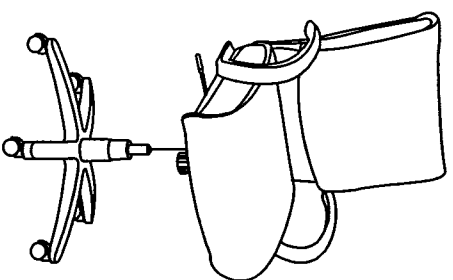

6. Carefully place chair assembly onto base assembly.

NOTE:

Periodically (Every 90 days) make sure screws are fully tightened.

OPERATING INSTRUCTIONS FOR CENTER PIVOT (BUTTERFLY) MECHANISM

1. **Seat Height Adjustment.**

To raise the seat, pull lever upward and raise your body up slightly to allow the chair to rise to the desired height.

To lower the seat, pull lever upward and apply weight downward on the seat.

Seat Upright Lock

To lock chair in upright position, lean forward and push knob toward chair.

To unlock chair in upright position, lean forward and pull knob away from chair.

2. **Tilt Tension Control Knob.**

Turn knob clockwise to increase tilt tension.

Turn knob counter-clockwise to decrease tilt tension.

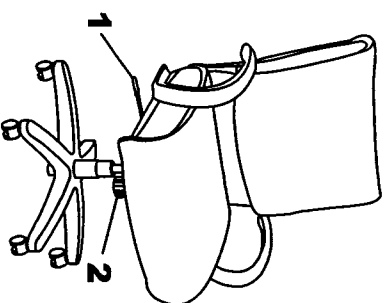

3