

ASSEMBLY INSTRUCTIONS
TECHNICAL SERIES
MULTI-TASK STOOL W/FOOTLOOP
MODEL NO. 2610

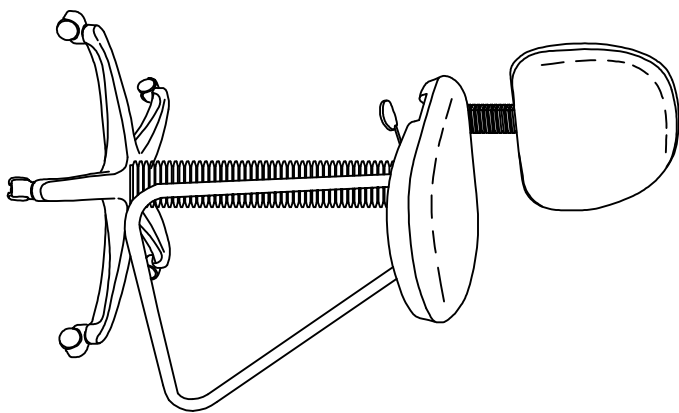













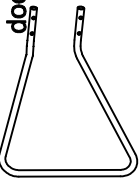
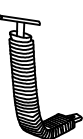

IMPORTANT!
Review ALL instructions before beginning assembly. These instructions are provided to avoid problems that may occur from improper assembly or installation. Mayline and/or its distributor are not responsible for failure resulting from improper assembly or installation of this product. Moreover, all warranties are void for failure to follow these assembly instructions.

Part No. 2610, Revision 03 05/28/10

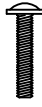

PARTS LIST 201U

When ordering components, specific color and/or size information may be required.
 Contact a Mayline Customer Service Representative. 1-800-822-8037
** Individual Items, Order by part number. ** Denotes Color Code*

Reference Letter A *	Quantity 1	Part Number CM407** Back	
Reference Letter B *	Quantity 1	Part Number CM417** Seat	
Reference Letter C *	Quantity 1	Part Number CM423 Mechanism	
Reference Letter D *	Quantity 5	Part Number CM210 Castor (5 per pack)	
Reference Letter E *	Quantity 1	Part Number CM202 Base	
Reference Letter F *	Quantity 1	Part Number CM432 Cylinder	
Reference Letter G *	Quantity 1	Part Number CM439 Cylinder Cover	
Reference Letter H *	Quantity 1	Part Number CM462 Footloop	
Reference Letter J *	Quantity 1	Part Number CM461 Back Post & Bellows	
Reference Letter K	Quantity 4	Part Number CM456 * Hardware Pack	
Reference Letter L	Quantity 2	Screw 1/4"-20 x 7/8"	
Reference Letter M	Quantity 4	Screw 1/4"-20 x 1-1/16"	
Reference Letter N	Quantity 1	Screw 1/4"-20 x 1-1/2"	
Reference Letter P	Quantity 1	Part Number CM462 Back Bracket (metal)	
Reference Letter R	Quantity 1	Part Number CM463 Back Bracket (plastic)	
Reference Letter S	Quantity 1	Knob of Mechanism	
Reference Letter S	Quantity 1	Allen Wrench	

(2)

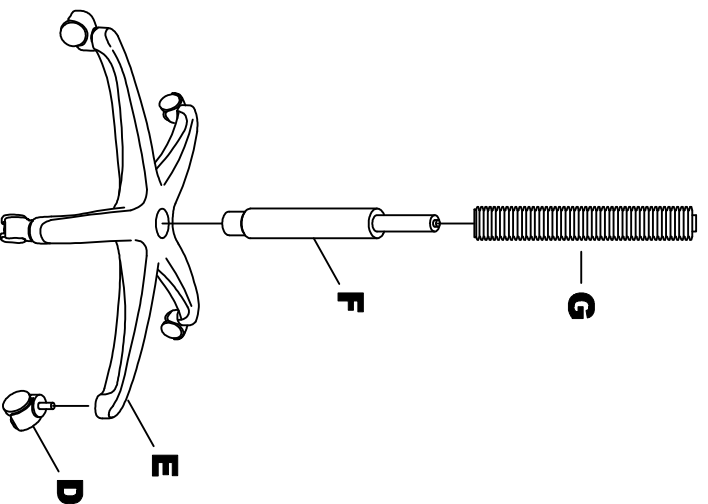

1. Place Base (E) upside down and push Casters (D) firmly into base. 5 places.
2. Turn Base right side up and insert Cylinder (F) into center hole of Base.
3. Place Cylinder Cover (G) over Cylinder.

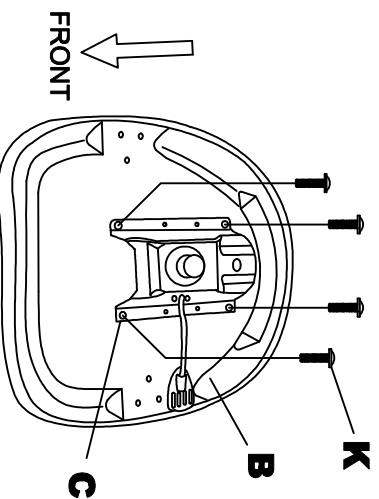

4. Assemble Mechanism (C) to Seat (B) using Screws (K) 4 places.

5. Assemble Footloop (H) to mechanism (C) using screws (M) 4 places.

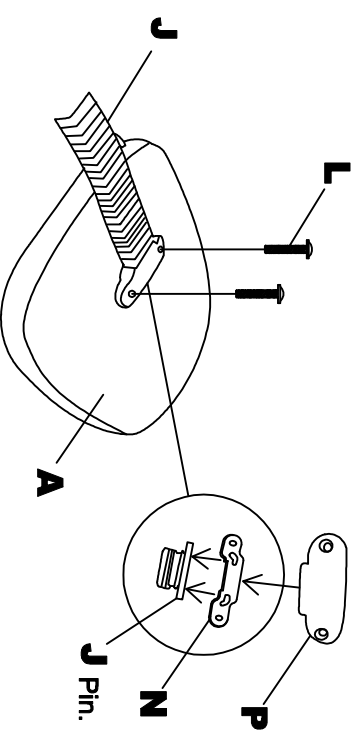
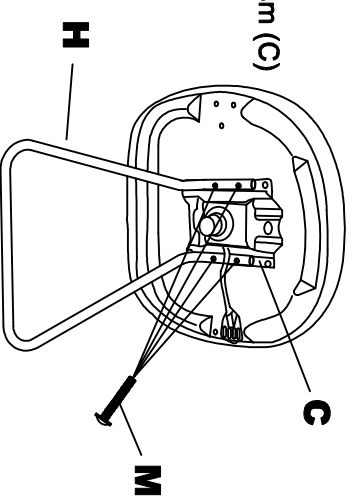

6. Assemble Pin of Back Post (J) into slots of Back Bracket (Metal) (N).
7. Assemble Back Post & Bellows (J) to Back (A) using Back Brackets (N & P) and attach using Screws (L) 2 places.

8. Assemble Back Assembly to Seat Assembly by sliding the Back Post (J) into Mechanism (C). Position to desired depth and tighten Knob (R).

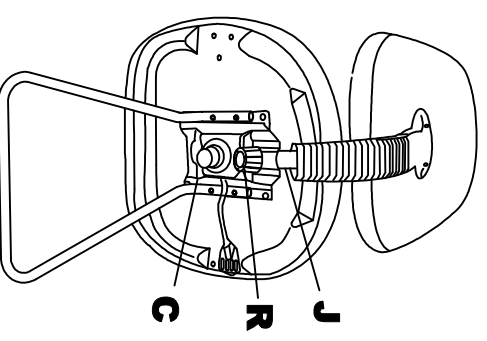

(4)

9. Carefully place seat assembly onto base assembly.

NOTE:
Periodically (Every 90 days) make sure all screws are fully tightened.

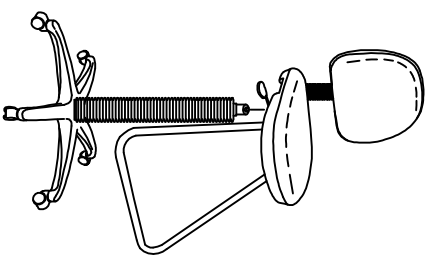

OPERATING INSTRUCTIONS FOR MECHANISM & CHAIR FEATURES

1. Seat Height Adjustment.

To raise the seat, pull lever upward and raise your body up slightly to allow the chair to rise to the desired height.

To lower the seat, pull lever upward and apply weight downward on the seat.

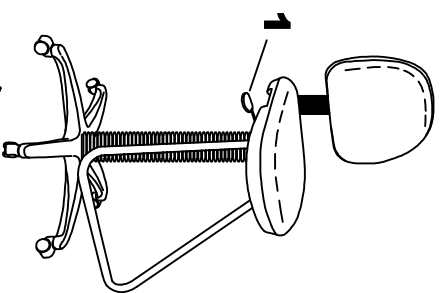

2. Seat Depth Adjustment.

To adjust the seat, loosen knob (counter-clockwise), Position to the desired depth and tighten knob (clockwise).

