

ASSEMBLY INSTRUCTIONS

TechWorks Organizer Frame





NOTE: Please count and inspect all pieces before disposing of any carton or packing materials.

COMPONENTS: When ordering components, specific color and/or size information may be required. Contact a Mayline Customer Service Representative. 1-800-822-8037

<u>REF. #</u>	<u>QTY.</u>	<u>DESCRIPTION</u>	<u>PART No.</u>	
1	4	CROSS WAY	CALL~~**	
2	4	UPRIGHT	CALL~~**	
3	2	CENTER UPRIGHT	CALL~~**	
4	1	L.H. FOOT	B7683**	** Denotes Color Code
5	1	R.H. FOOT	B7684**	~~Denotes Size
6	1	CONNECTOR	CALL~~**	
7	1	CONNECTOR COVER	CALL~~**	

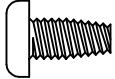
HARDWARE BAG (PART No. A7700)

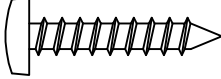
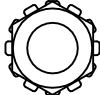
*for individual item, order that part number

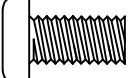
<u>REF. #</u>	<u>QTY</u>	<u>DESCRIPTION</u>	<u>PART No.</u>		
E1	6	#10-32 X 1/2 SCREW	X204*		
E2	21	#10 X 1 SCREW	X12*		
E3	4	5/16-18 KEPS NUT	T108*		
E4	60	5/16-18 X 3/4 SCREW	X410*		

1. Laying on a non-scatching surface, place Uprights (2 and 3) in Crossway (1) and attach using Screws (E4). Do not tighten Screws.

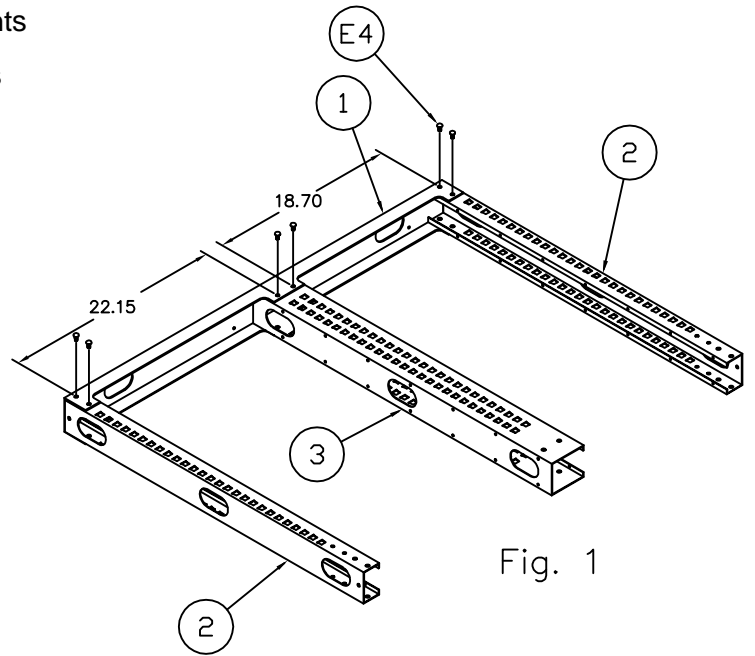

Fig. 1

*Be sure all upright trapezoidal holes are orientated in the same direction.



2. Place remaining Crossway (1) onto the opposite end of the Uprights (2 and 3) and attach using Screws (E4). Do not tighten.

3. Square the assembly by measuring diagonally.

4. Tighten all Screws (E4).

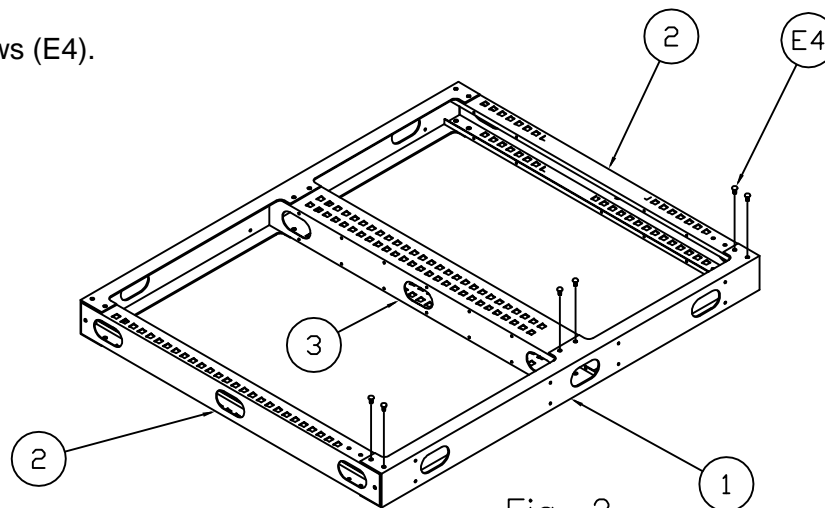

Fig. 2

5. Flip assembly over and install Screws (E4).

6. Repeat Steps 1, 2 & 3.

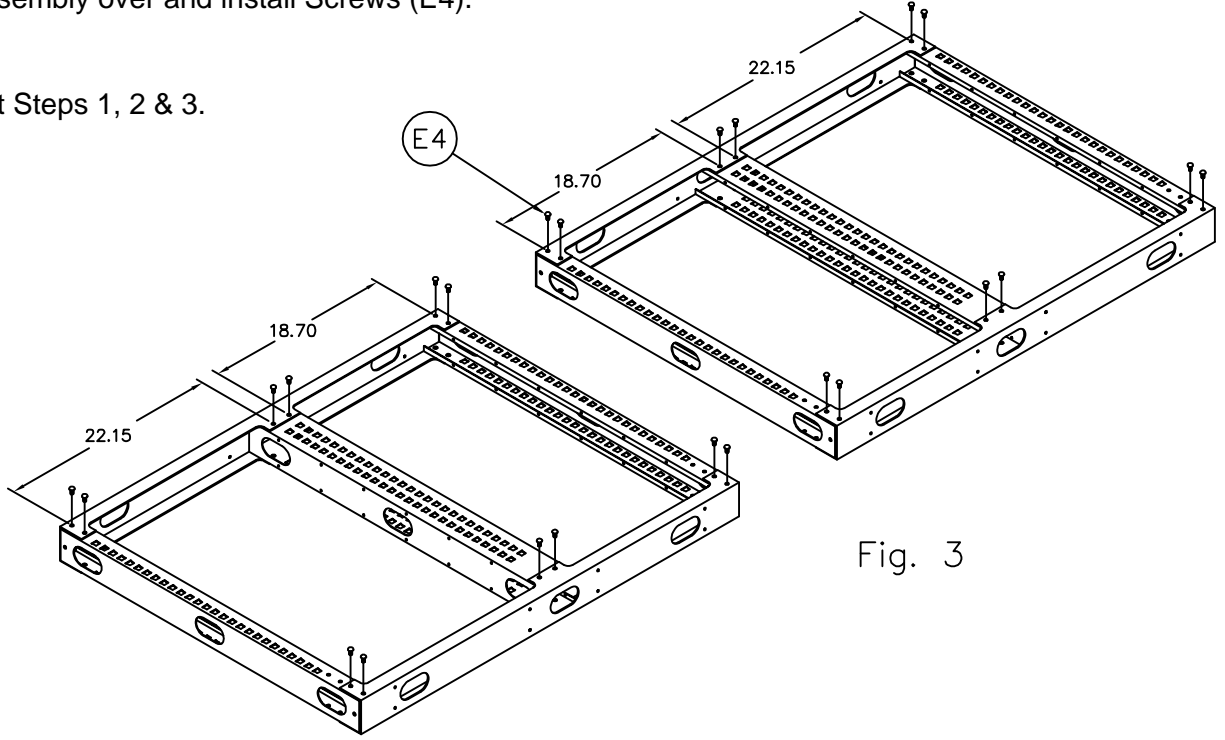

Fig. 3

7. Remove grommets from top of worksurface.

8. Place Organizer Frame Assembly onto worksurface and align grommet holes in Crossway (1) and attach using Screws (E2).

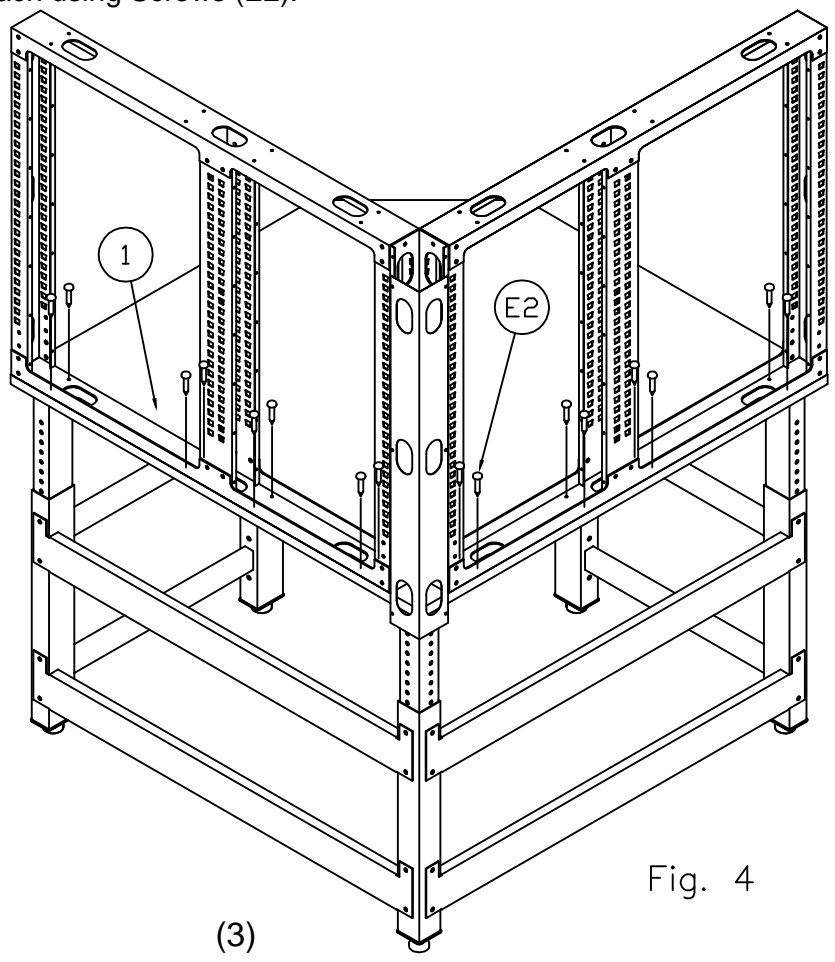

Fig. 4

(3)

9. Place Connector (6) against corner uprights and secure using Screws (E3) and Nuts (E4).

10. Place Connector Cover (7) over Connector and attach with Screws (E1).
See Fig. 5

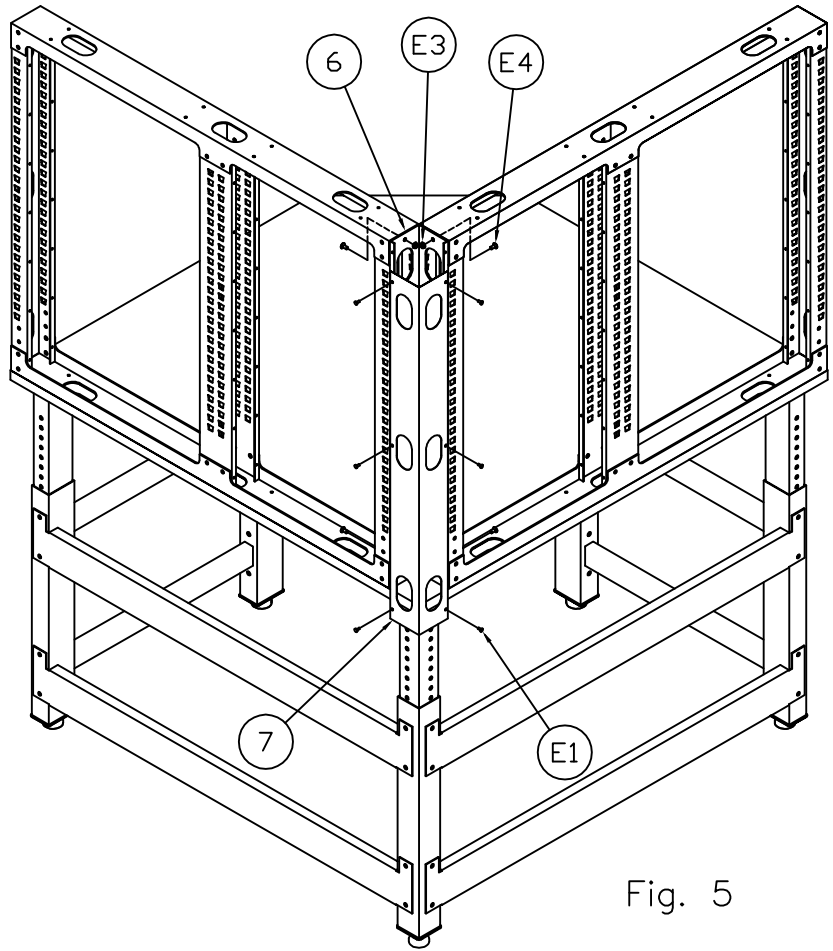

Fig. 5

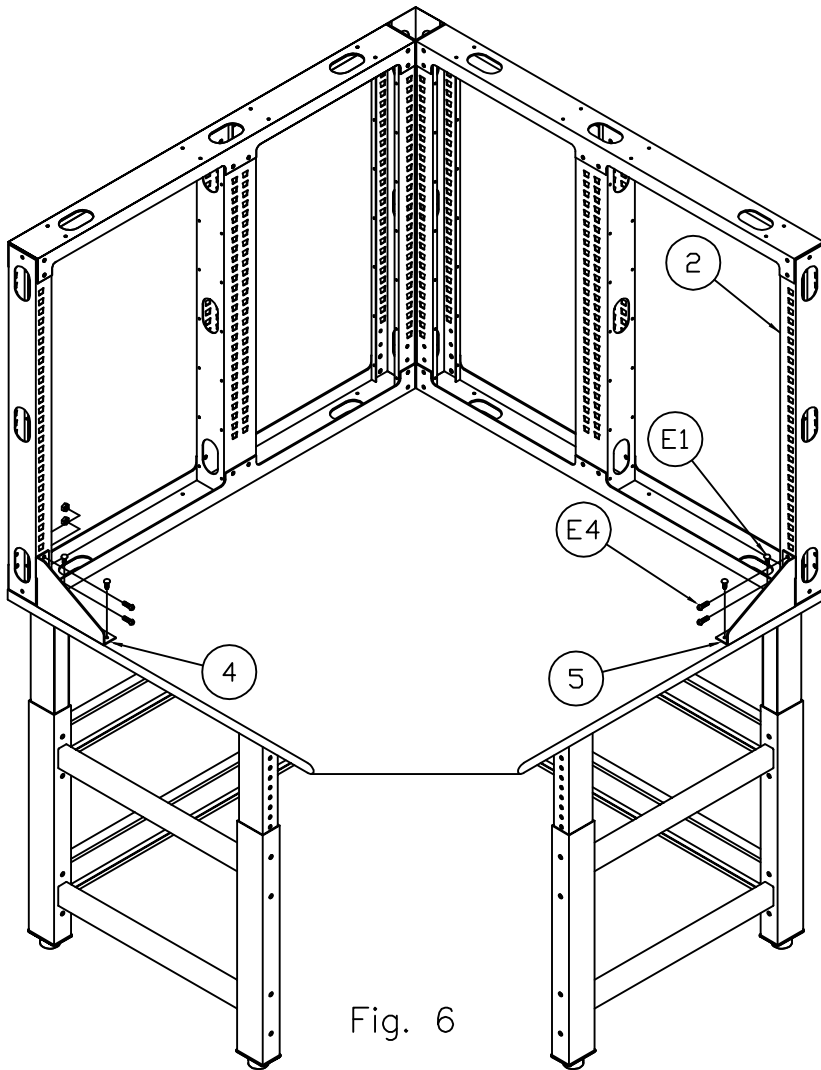

Fig. 6

11. Attach Feet (4 and 5) to outer Uprights (2) using Screws (E4). Do Not Tighten.

12. Using Screws (E1) attach feet to worksurface by pushing feet tight against the upright. Making sure upright is perpendicular to floor.

13. Tighten Screws (E4).

14. Replace grommets into holes.