

# ASSEMBLY INSTRUCTIONS CSII RECEPTION COUNTER

---

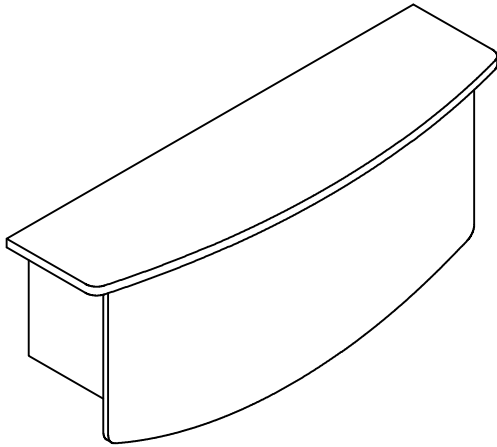

Product No.: CS2RC

## COMPONENTS:

<u>REF. #</u>	<u>QTY.</u>	<u>DESCRIPTION</u>	<u>PART No.</u>
1	1	TOP	L6667**
2	1	RIGHT SIDE PANEL	L6668**
3	1	LEFT SIDE PANEL	L6669**
4	1	FRONT PANEL	L6666**

\*\* Denotes Color Code

## HARDWARE BAG (A7895)

*\* for individual item, order that part number*

<u>REF. #</u>	<u>QTY</u>	<u>DESCRIPTION</u>	<u>PART NUMBER</u>
E1	11	Rafix-SE housing	X415*
E2	11	Rafix Bolt	X416*
E3	2	TAPE	E515*



**NOTE:** Please count and inspect all pieces before disposing of any carton or packing materials.

When ordering components, specific color and/or size information may be required.  
Contact a Mayline Customer Service Representative. 1-800-822-8037

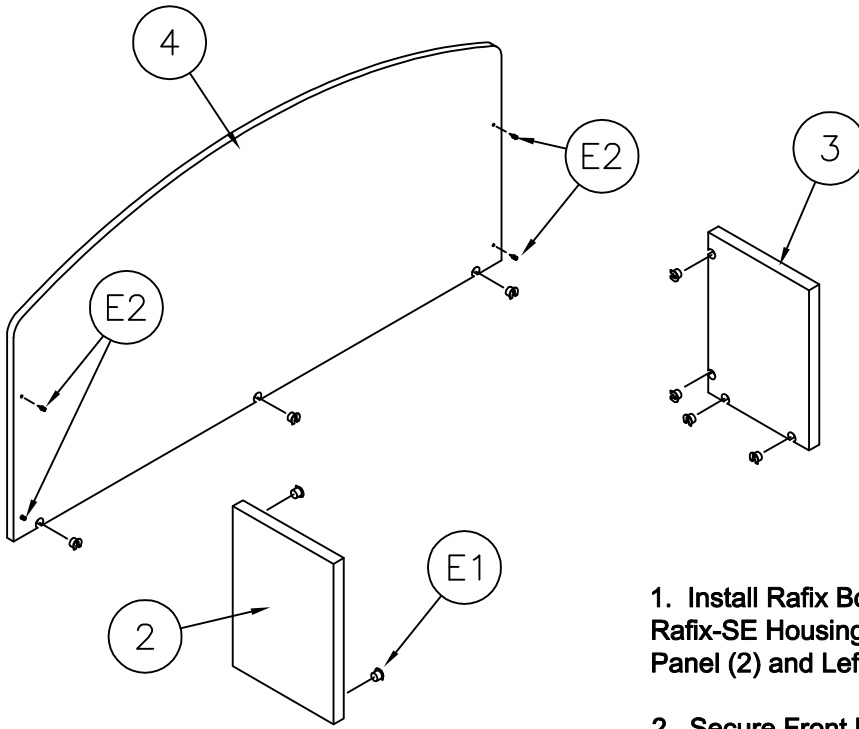

1. Install Rafx Bolt (E2) into the Front Panel (4). Insert Rafx-SE Housings (E1) into Front Panel (4), Right Side Panel (2) and Left Side Panel (3).

2. Secure Front Panel (4) to Side Panels (2 & 3) by turning screw in each Rafx-SE Housing (E1).

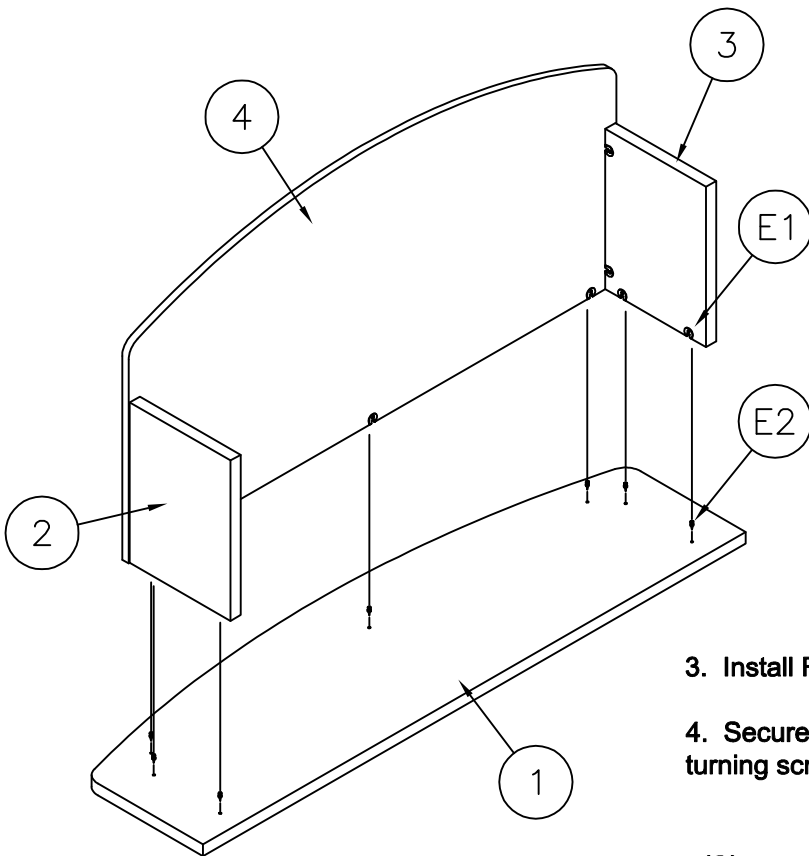

3. Install Rafx Bolt (E2) into the Top Panel (1).

4. Secure Front Panel / Side Panel assembly to Top (1) by turning screw in each Rafx-SE Housing (E1).

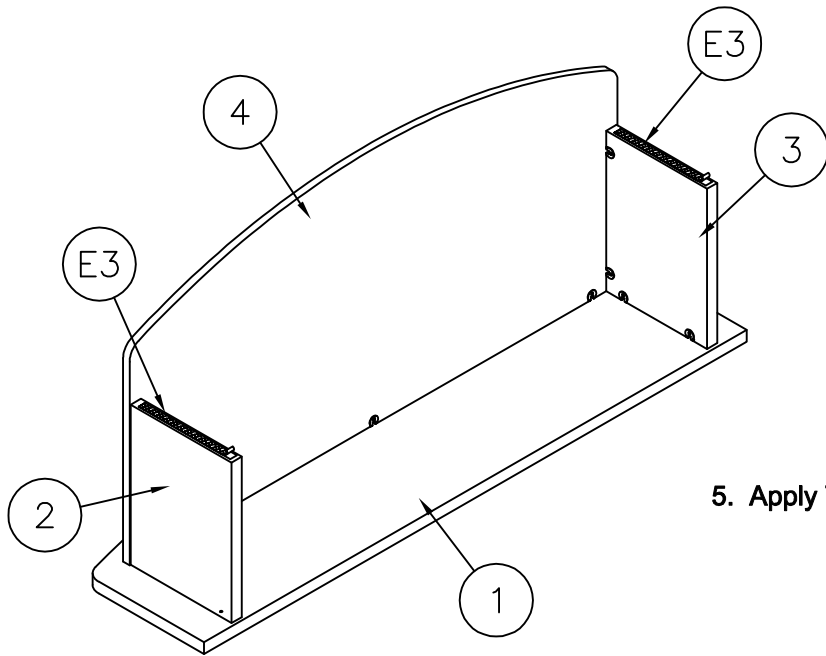

5. Apply Tape Strips (E3) to bottom of each Side Panel (2 & 3).

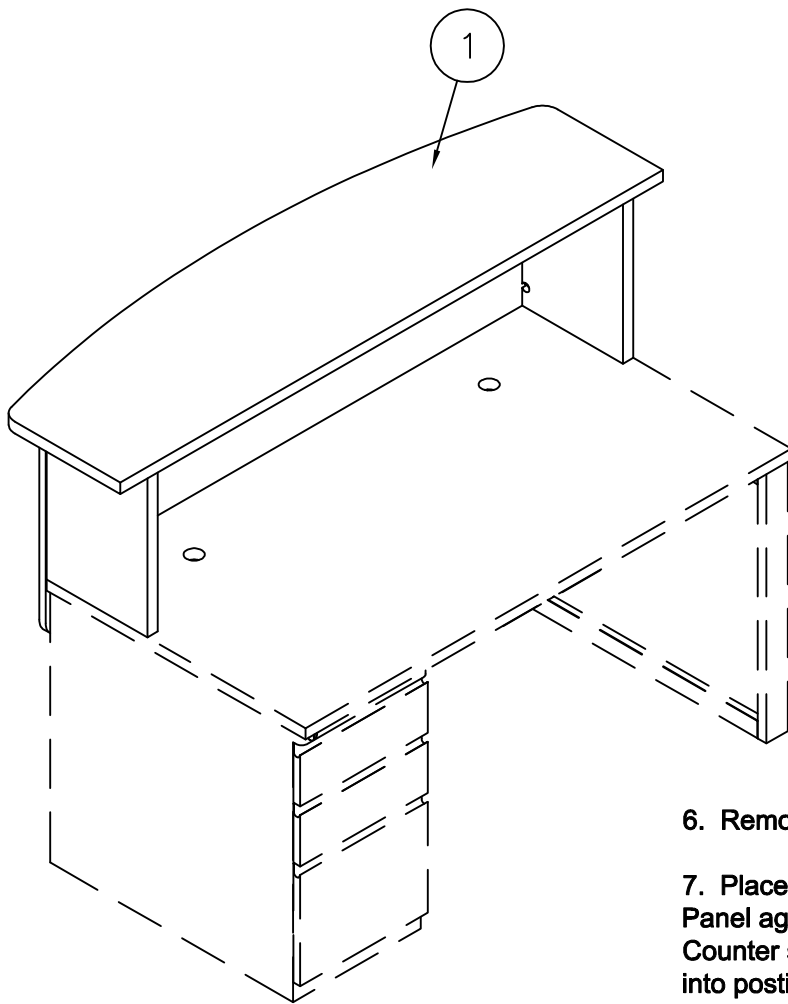

6. Remove protective backer from Tape strips (E3).

7. Place the inside surface of the Reception Counter Front Panel against the desk front edge. Center the Reception Counter side to side. Lower Reception Counter assembly into position and press firmly in place.

(3)