

ASSEMBLY INSTRUCTIONS

Ortho Comfort Series

Executive Posture Chair (Leather)

Model No. 9414AAGL

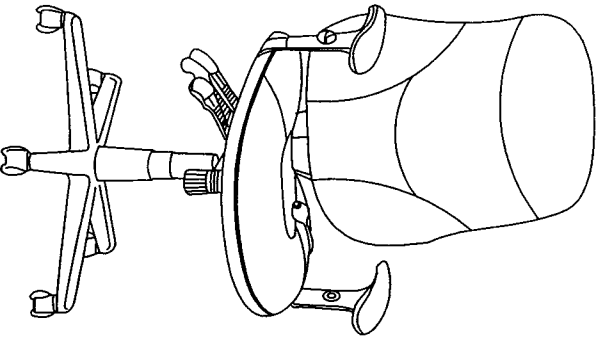

Tiffany Industries™

A MAYLINE GROUP COMPANY

619 N. Commerce, P.O. Box 728
Sheboygan, WI 53082-0728

Toll Free: 1-800-822-8037
FAX: 920-457-7388
On Line: www.mayline.com

P/N 9414AAGL REV 02 10/07

PARTS LIST 9414AAGL

When ordering components, specific color and/or size information may be required. Contact a Mayline Customer Service Representative. 1-800-822-8037

* Individual Items, Order by part number.

** Denotes Color Code.

Reference Letter	A*	Quantity	
Part Number	102004** Back		
Reference Letter	B*	Quantity	
Part Number	102005** Seat		
Reference Letter	C*	Quantity	
Part Number	12ADJARM Arms (pair)		
Reference Letter	D*	Quantity	
Part Number	102014 Mechanism		
Reference Letter	E*	Quantity	
Part Number	101400 Caster (5 per pack)		
Reference Letter	F*	Quantity	
Part Number	102012 Base		
Reference Letter	G*	Quantity	
Part Number	102016 Cylinder		
Reference Letter	H*	Quantity	
Part Number	102018 Cylinder Cover		
Reference Letter	J*	Quantity	
Part Number	102029 Knob		
Part Number	102021* Hardware Bag	Quantity	Spare
Reference Letter	K	8	1
Reference Letter	L	2	1
Reference Letter	M	2	
Reference Letter	N	1	

1

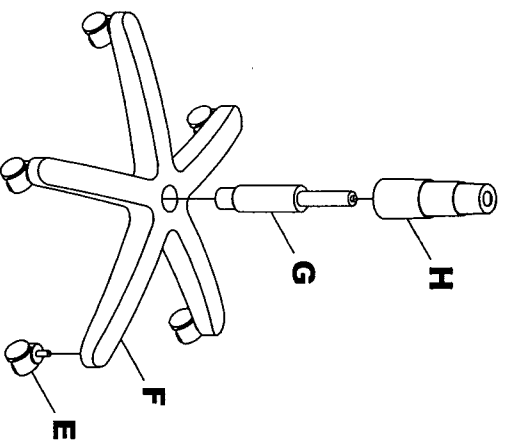

1. Place Base (F) upside down and push Casters (E) firmly into base. 5 places.
2. Turn Base right side up and insert Cylinder (G) into center hole of Base.
3. Place Cylinder Cover (H) over Cylinder.

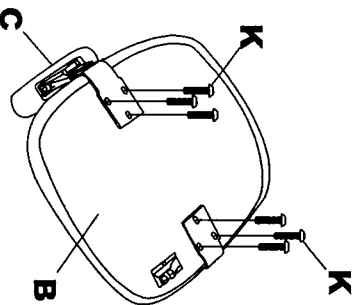

4. Assemble Arms (C) 2 places onto Seat (B) using Screws (K) 6 places.

2

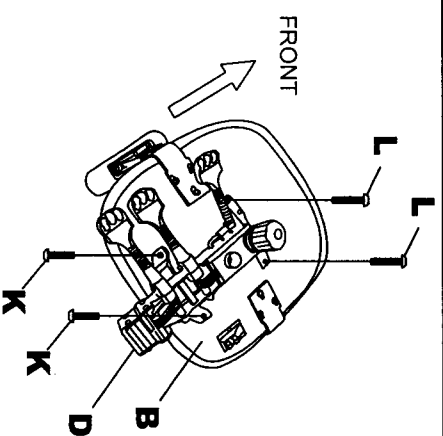

5. Assemble Mechanism (D) to Seat (B) using Screws (L) 2 places located in front of Seat and using Screws (K) 2 places as shown.

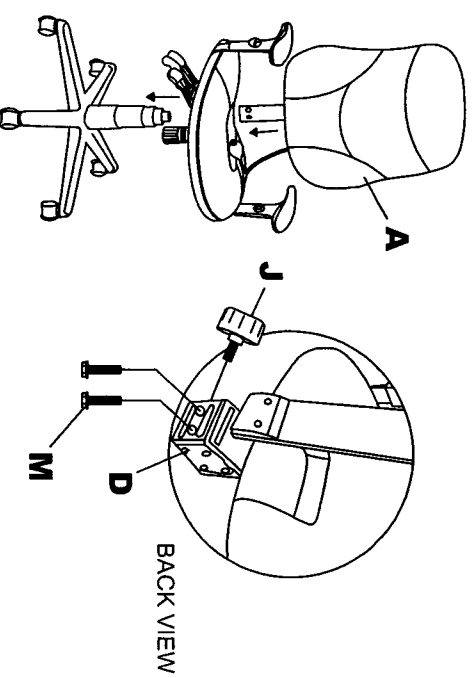

6. Carefully place seat assembly onto base assembly.
7. Assemble Back (A) to Mechanism (D) using Screws (M) 2 places & Knob (J).

NOTE:
Periodically (Every 90 days) make sure all screws are fully tightened.

3

**OPERATING INSTRUCTIONS FOR
MULTI-FUNCTION MECHANISM & CHAIR FEATURES**

1. Back Posture Adjustment

To adjust angle of the back, pull paddle up.
Adjust back, push knob down to lock.

2. Seat Posture Adjustment

To adjust angle of the seat, pull paddle up.
Adjust seat, push knob down to lock.

3. Seat Height Adjustment.

To raise the seat, pull lever upward and raise
your body up slightly to allow the chair to rise to
the desired height.

To lower the seat, pull lever upward and apply
weight downward on the seat.

4. Tilt Tension Control Knob.

Turn knob clockwise to increase tilt tension.
Turn knob counter-clockwise to decrease tilt tension.

5. Ratcheting Back Height Adjustment.

To raise the back, lift up to the desired height.

To lower the back, lift up to the utmost position and
lower to starting position. Lift up to the desired height.

