

# ASSEMBLY INSTRUCTIONS

## for BASIC TABLE

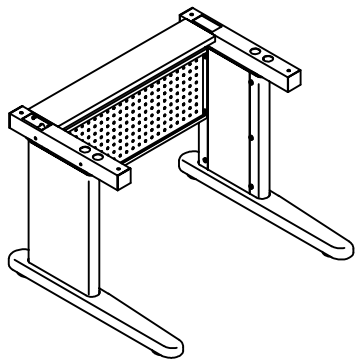

### Hardware

- A. M6 x 8 Screw (8)
- B. Crank Handle (1)
- C. Particle Board Screw (6)  
(included with top)

### Components:

- D. Right Leg Assembly (1)
- E. Left Leg Assembly (1)
- F. Modesty Panel (1)
- G. Cross Brace Support (1)
- H. Hex Shaft (1)

NOTE: Assemble the unit on its side.

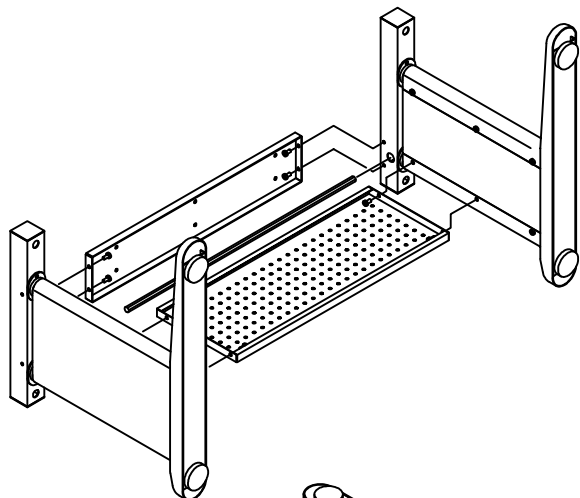

1. Loosely attach the Cross Brace Support (G) to the Left and Right Leg Assemblies (D & E) using 4 Screws (A).
2. Insert the Hex Shaft (H) into the hex socket near the top of each Leg Assembly. DO NOT attempt to rotate the shaft till it has been inserted into both end assemblies.
3. Loosely attach the Modesty Panel (F) to the Leg Assemblies using 4 Screws (A)
4. Tighten all screws.

NOTE: If you have ordered the OPTIONAL Trim Panels, install them NOW per the instructions that are included with that product.

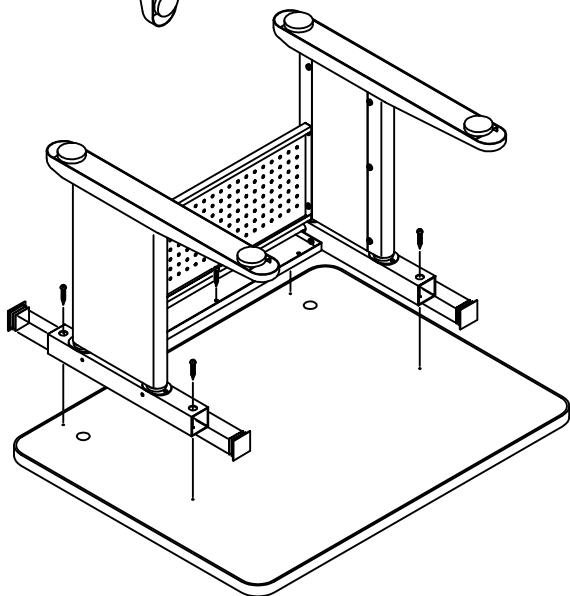

5. Place the Worksurface face down onto a solid protected surface.
6. Invert the assembled Base and align the holes in the top mounting tubes with the holes in the underside of the worksurface. Removing the end caps from the Leg Assembly tubes will allow you to better see the alignment of the holes.
7. Attach the Base to the worksurface with 2 Screws (C) per tube. Replace the tube end caps.
8. Secure the Cross Brace Support (F) to the top with 2 Screws (C) in the center holes of the Support.
9. Turn the table over onto its legs and adjust the levelers as required.
10. Insert Crank Handle (B) into either worksurface hole to adjust table height.

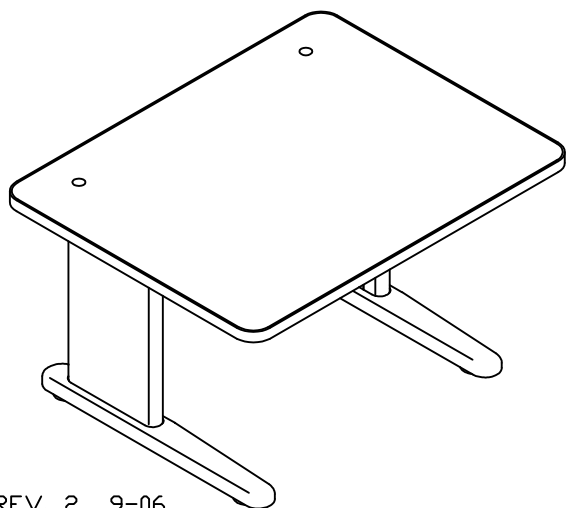

**MAYLINE**® Mayline Company, LLC  
 619 N. Commerce, P.O. Box 728  
 Sheboygan, WI 53082-0728  
 Toll Free: 1-800-822-8037  
 FAX: 920-457-7388  
 On Line: [www.mayline.com](http://www.mayline.com)