

ASSEMBLY INSTRUCTIONS

Mercado Corsica High-Back Chair

Model No. CS

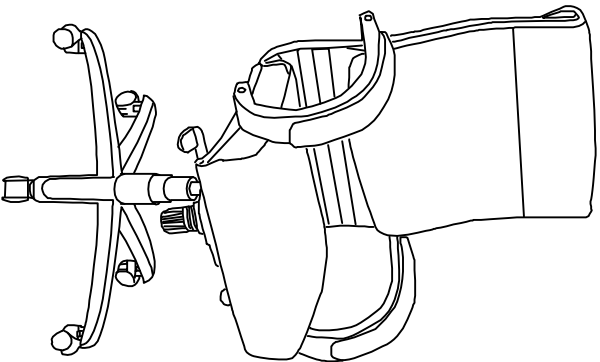







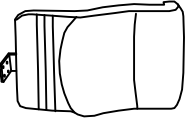
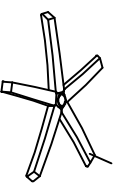

PARTS LIST CS

When ordering components, specific color and/or size information may be required. Contact a Mayline Customer Service Representative. 1-800-822-8037

* Individual Items. Order by part number.

** Denotes Color Code.

Reference Letter A*		Quantity 1	Reference Letter F*	101589** Base Cover	Quantity 1
Part Number 101458** Back			Part Number 101493** Base		
Reference Letter B*		Quantity 1	Reference Letter Fa*	101408-mah, 101409-cry, 101410-gch, Base Cover	PRE 09/2008
Part Number 101489** Seat			Part Number 101438-mah, 101439-cry, 101440-gch, Base		
Reference Letter C*		Quantity 2	Reference Letter G*		Quantity 1
Part Number 101434-gch, 101435-cry, 101436-mah Arms (pair)			Part Number 101401 Cylinder		
Reference Letter D*		Quantity 1	Reference Letter H*		Quantity 1
101425 Height Lever			Part Number 101406 Cylinder Cover		
Part Number 101402 Mechanism			Reference Letter Ha*		PRE 09/2008
Reference Letter E*		Quantity 5	Part Number 101407** Cylinder Cover		
Part Number 101400 Caster (5 per pack)					

Parts List continued on page 2

1

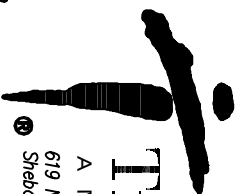

Tiffany Industries™







A MAYLINE GROUP COMPANY

619 N. Commerce, P.O. Box 728
Sheboygan, WI 53082-0728

Toll Free: 1-800-822-8037

FAX: 920-457-7388

On Line: www.mayline.com

Part Number *		
101416-mah, 101417-cry, 101418-gch Hardware Bag		
Reference Letter		Quantity
J	Screw 5/16-18 x 1"	6
Reference Letter		Quantity
K	Screw 5/16-18 x 1-1/4"	2
Reference Letter		Quantity
L	Screw 5/16-18 x 2-1/2"	4
Reference Letter		Quantity
N	Allen Wrench	1
Reference Letter		Quantity
M	Arm Plug	4
Reference Letter		Quantity
G	Cylinder	1

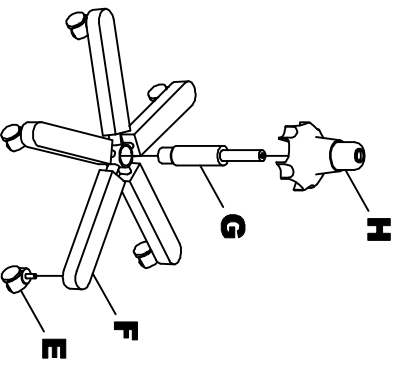

1. Place Base (F) upside down and push Casters (E) firmly into base. 5 places.
2. Turn Base right side up and insert Cylinder (G) into center hole of Base.
3. Place Cylinder Cover (H) over Cylinder and push down onto Base.

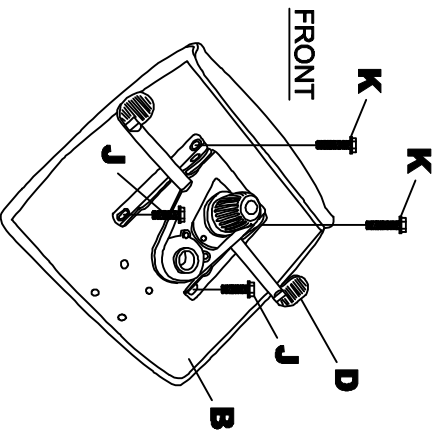

4. Assemble Mechanism (D) onto Seat (B) using Screws (K) 2 places located in front of Seat and using Screws (J) 2 places as shown.

2

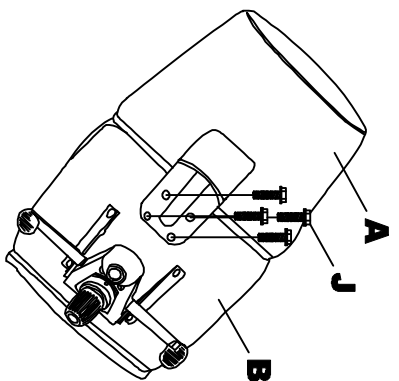

5. Assemble Back (A) onto Seat (B) using Screws (J) 4 places. **DO NOT TIGHTEN SCREWS** at this time. This will allow a tolerance when assembling arms.

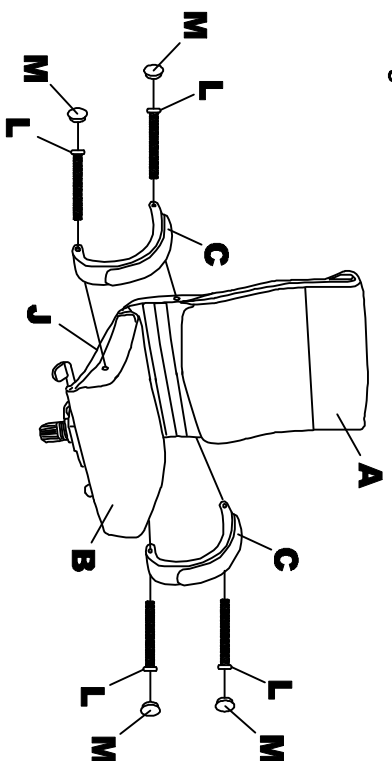

6. Assemble Arm (C) 2 places onto Back (A) & Seat (B) using Screws (L) 4 places. **DO NOT TIGHTEN SCREWS** at this time.
7. After both arms are installed tighten all Screws (L) 4 places, Screws (J) 4 places.
8. Insert Arm Plug (M) into Arm (C) 4 places.

3

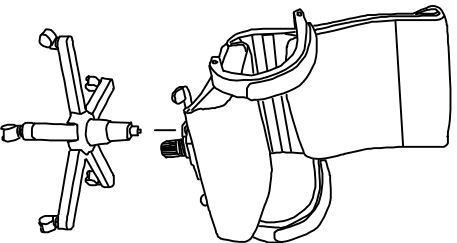

8. Carefully place chair assembly onto base assembly.

NOTE:
Periodically (Every 90 days) make sure screws are fully tightened.

OPERATING INSTRUCTIONS FOR DELUXE KNEE-TILT MECHANISM

- 1. Seat Height Adjustment.**
To raise the seat, pull lever upward and raise your body up slightly to allow the chair to rise to the desired height.
To lower the seat, pull lever upward and apply weight downward on the seat.
- 2. Seat Tilt Adjustment Lock**
Pull lever upward and allow the chair to tilt backwards.
To lock to the desired position push lever downward.
To release tilt adjustment, pull lever upward, apply weight onto the back cushion and then lean forward.
- 3. Tilt Tension Control Knob.**
Turn knob clockwise to increase tilt tension.
Turn knob counter-clockwise to decrease tilt tension.

