

ASSEMBLY INSTRUCTIONS

GENEVA CONFERENCE TABLE (2 LEGS)

NOTE: Please count and inspect all pieces before disposing of any carton or packing materials.

COMPONENTS

When ordering components, specific color and/or size information may be required. Contact a Mayline Customer Service Representative. 1-800-822-8037

REF#	QTY.	DESCRIPTION	PART NO.	
1	1	Top	CALL ~-~**	** Denotes Color Code
2	2	Leg Assembly	CTL1**	~-~ Denotes Size
3	1	Stiffener	CALL ~-	* Individual Items, Order by part number.

HARDWARE BAG (Part No. 610248) Qty. 2 *

REF#	QTY.	DESCRIPTION	PART NO.
E1	8	Screw, 1/4-20 x 3/4	700124



Tools Required for Assembly

Phillips Screw Driver

Note: A Magnetic or Power Driver may be used to assist in assembly.

1. Begin Assembly by placing the Top (1) face down on a clean flat work surface. Attach Leg Assembly (2) onto Table Top (1) using Screws (E1). Do Not Tighten. See Fig. #1.

2. Locate and position Stiffener (3) on the 1" side and slide into tab on mounting plate of the Leg Assembly (2). See Fig. #1.

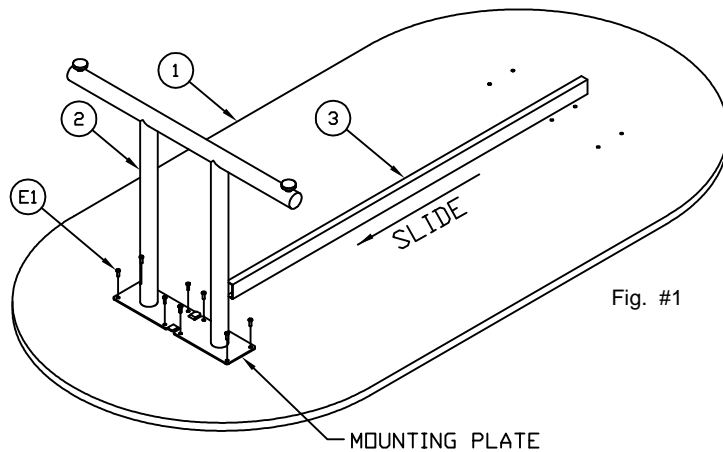

Fig. #1

3. Slide tab on mounting plate of Leg (2) into Stiffener (3) and Attach to Top (1) using Screws (E1). See fig. #2.

4. Tighten all Screws (E1). See Fig. #1 and #2.

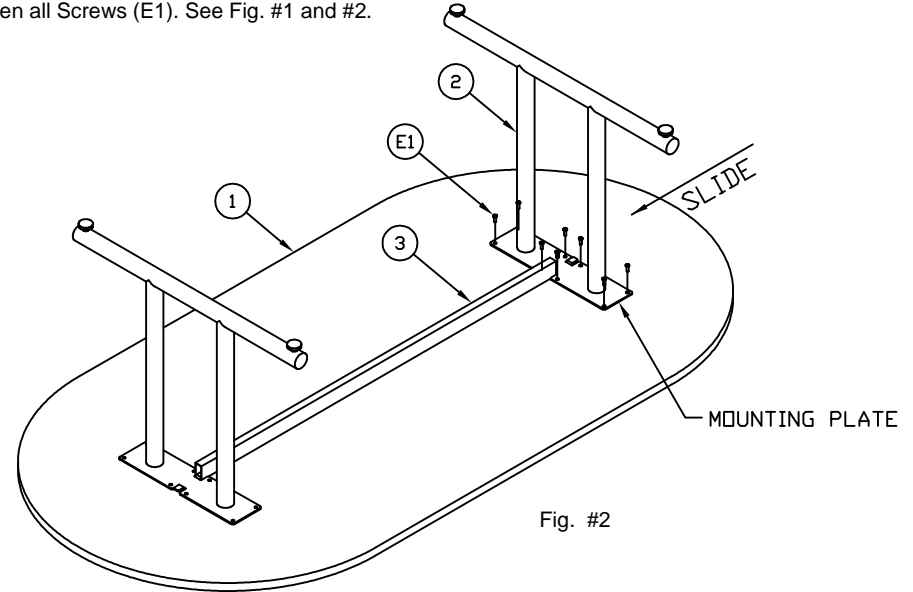
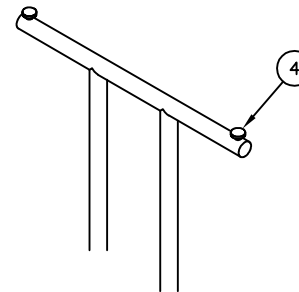

Fig. #2

WARRANTY PARTS IDENTIFICATION NOT INCLUDED IN ASSEMBLY

REF#	QTY.	DESCRIPTION	PART NO.	
4	2 per leg	Leveler	428670 *	* Individual Items, Order by part number.



Tiffany Industries™
 A MAYLINE GROUP COMPANY
 619 N. Commerce, P.O. Box 728 Toll Free: 1-800-822-8037
 Sheboygan, WI 53082-0728 FAX: 920-457-7388
 On Line: www.mayline.com

ASSEMBLY INSTRUCTIONS

GENEVA CONFERENCE TABLE (3 LEGS)

NOTE: Please count and inspect all pieces before disposing of any carton or packing materials.

COMPONENTS When ordering components, specific color and/or size information may be required. Contact a Mayline Customer Service Representative. 1-800-822-8037

REF#	QTY.	DESCRIPTION	PART NO.	
1	1	Top	CALL ~-~**	** Denotes Color Code
2	3	Leg Assembly	CTL1**	~-~ Denotes Size
3	2	Stiffener	CALL ~-	* Individual Items, Order by part number.

HARDWARE BAG (Part No. 610248) Qty. 3*

REF#	QTY.	DESCRIPTION	PART NO.
E1	8	Screw, 1/4-20 x 3/4	700124

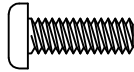

Tools Required for Assembly
Phillips Screw Driver

Note: A Magnetic or Power Driver may be used to assist in assembly.

1. Begin Assembly by placing the Top (1) face down on a clean flat work surface. Attach Leg Assembly (2) onto center of Table Top (1) using Screws (E1). Do Not Tighten. See Fig. #1.

2. Locate and position two Stiffeners (3) on the 1" side and slide into tab on mounting plate of the Leg Assembly (2). See Fig. #1.

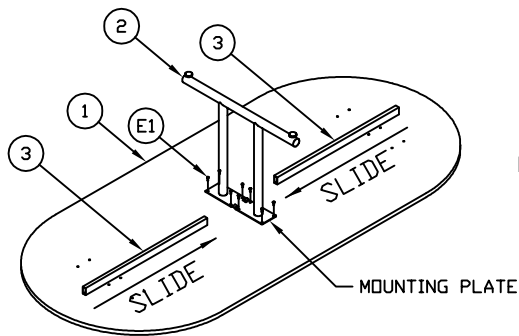

Fig. #1

3. Slide tab on mounting plate of Leg (2) into Stiffener (3) and Attach to Top (1) using Screws (E1). Do Not Tighten. See Fig. #2.

4. Repeat Step 3 for remaining Leg.

5. Tighten all Screws (E1). See Fig. #1 and #2.

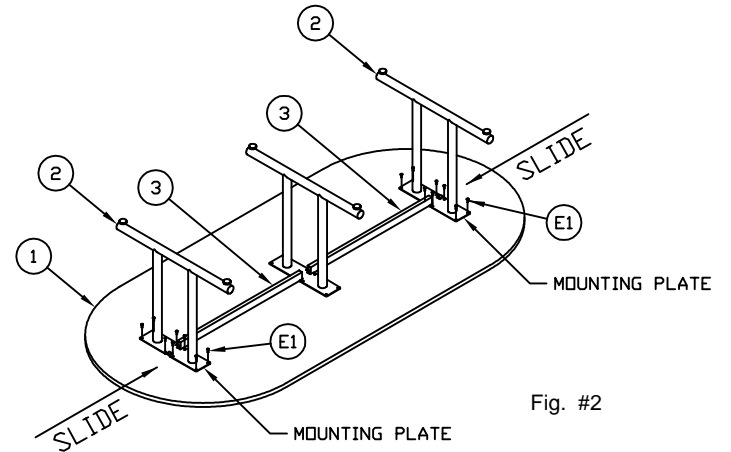

Fig. #2

WARRANTY PARTS IDENTIFICATION NOT INCLUDED IN ASSEMBLY

REF#	QTY.	DESCRIPTION	PART NO.	
4	2 per leg	Leveler	428670 *	* Individual Items, Order by part number.

