

Assembly Procedures for Kwik Track

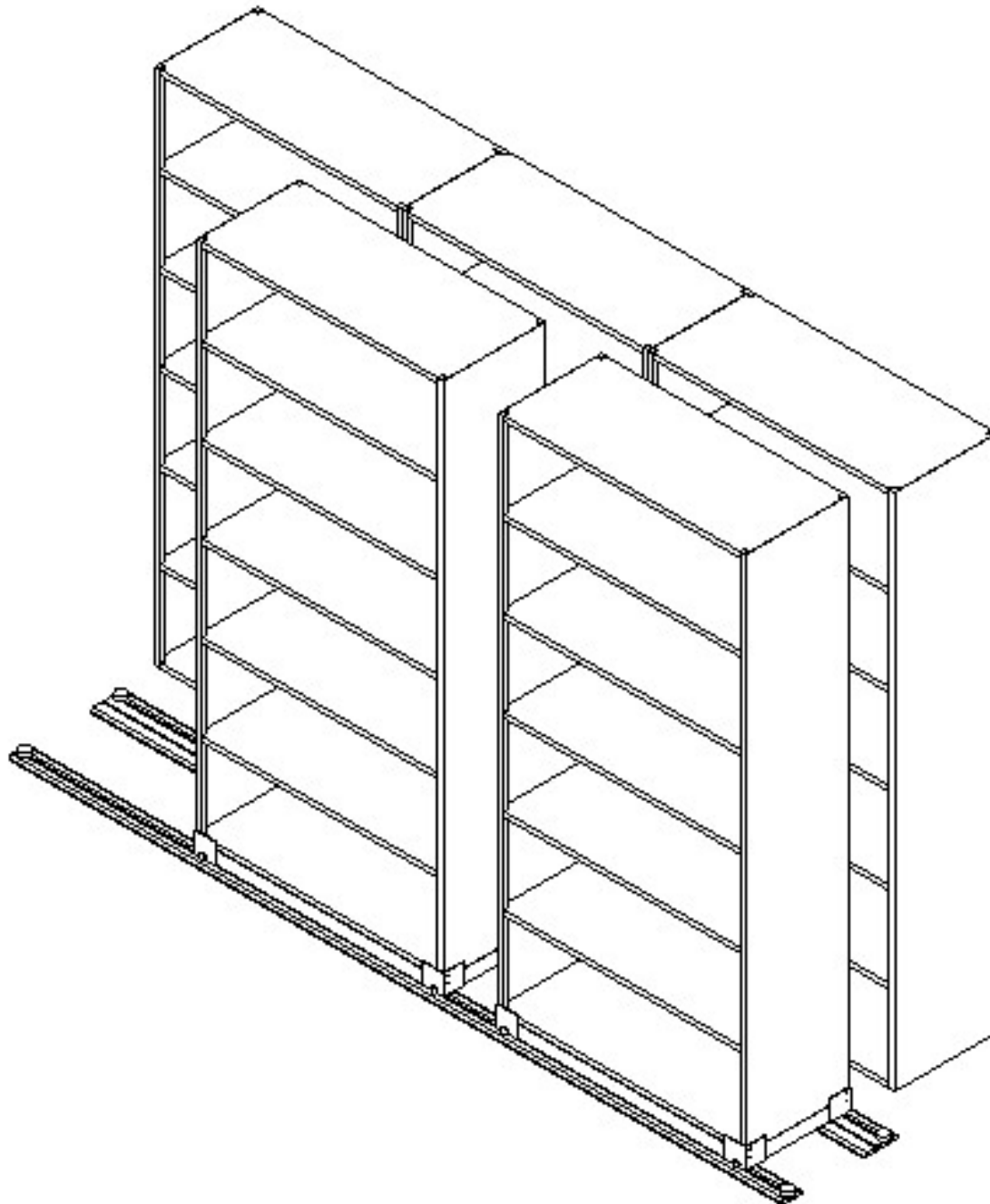

Kwik-File, LLC
490 Northco Drive
Minneapolis, MN 55432
Phone: 1-800-822-8037
Fax: 920-457-7388
Online: www.kwikfile.com

KWIK TRACK INSTALLATION

Kwik-File recommends the removal of all carpet and padding prior to installing Kwik-Track. We suggest that carpet be removed the length and width of each track. Product performs best when installed on concrete or tile. NOTE: Kwik-File cannot assure proper leveling if track is installed on low-pile carpet

- Read all instructions before attempting assembly.
- Check floor plan layout. Measure and mark floor for intended layout, preplan exact location of all units with regards to columns, lights, windows and obstructions.
- Check levelness of floor in the proposed install area

GENERAL NOTES:

1. Installation of the in track anti-tip track begins with the layout of the floor plan. It is imperative for the proper operation of the system that the tracks be parallel, level and square. On a two track system, the in track anti-tip is the rear track.
2. The carriage with the anti tip guide is designed to be inserted into the track after the track is in the approximate location, but prior to completely securing it to the floor. This will eliminate the need to dis-assemble the guide from the carriage.
3. The carriage is shipped completely assembled, however if the anti tip guide assembly cannot be inserted into the track it is possible to remove and reinstall the mount assembly. Loosen ¼" bolts and remove anti-tip brackets. Place carriage on track. Care must be taken to properly place the mounts tightly to the channel and angle of the carriage during re-assembly. Re-use fasteners.
4. **The KTT track kits are pre packaged to include mounting hardware, end stops and shim material. If KTT track kits are used in conjunction with each other to obtain longer track runs, slide the underlayment of one track into the other.** This will insure proper track alignment. Finish splice per instructions below.

Detail of Anti Tip Guide

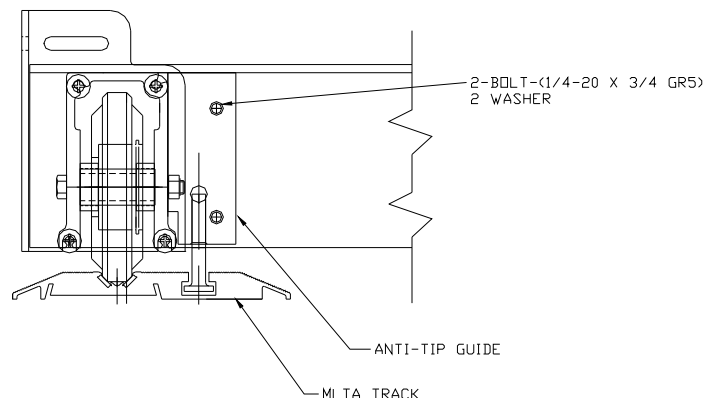

5. Required tools:

- hammer drill (concrete drill bits are provided in the hardware bag)
- cordless (or electric drill motor)/Phillips screw adapter
- flat and Phillips screwdriver
- 9/16 socket
- hammer
- measuring tape
- chalk line
- level (360 Degree Rotary Laser Level is best suited)

The in track anti-tip track (MLTA) as shown will be shipped with the heavy-duty track as shown below. (MLT)

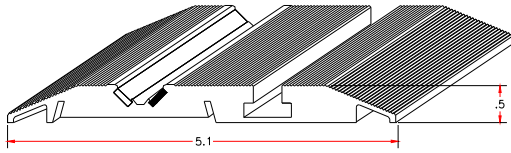

MLTA Track

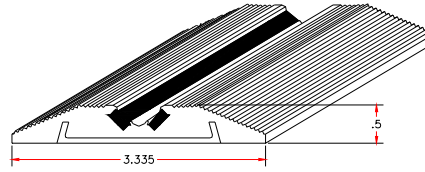

MLT track

- Install Stationary Shelving per layout (Refer to 'Typical Stationary Placement' in these instructions)
- Use stationary shelving to assist in aligning track and mobile carriages. The tracks should extend beyond the stationary shelving at equal dimensions on either side.
- Align assembled track parallel to stationary shelving or aisle, with approximately 1 1/2" clearance from any obstacle. The MLTA track will be the rear track of the two track lateral system. Using the hole(s) in the track as a guide, drill a 1/4" hole(s) into the concrete floor deep enough for the end fastener(s). Clean concrete dust from hole. Level track using shims provided. The track must be supported along its entire length.
- Hammer the fastener(s) through the end of track into the floor.
- Confirm joints are still properly seated, track is straight and level.

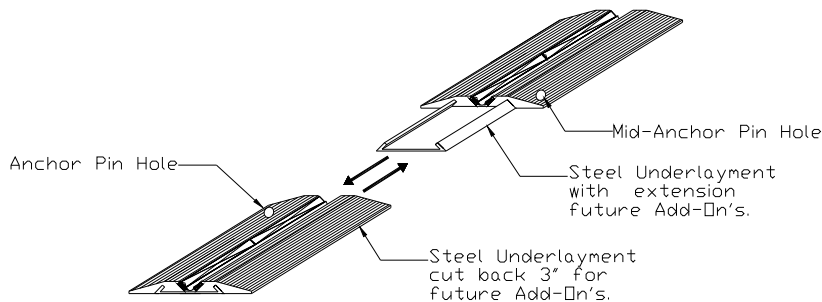

- **INSTALL BUMPER ON ONE END OF MTLA TRACK. BE SURE TEE NUT FOR OPPOSITE BUMPER IS UNDER TRACK PRIOR TO FINAL FLOOR ANCHORING.**

- Maintaining careful alignment of the MLTA, drill a 3/8" holes and install mid-track (3/8" x 3" HILTI Concrete) bolts in every available anchor point in the track. The strength of the anti-tip is in the anchors. Make sure they are tightened properly.

CAUTION: Hole depth for 3/8" Hilti bolt must be consistent depth as to prevent tripping hazard.

- Once the anti tip track is secured, the remaining tracks can be set in the approximate location.
- Place one carriage on the track to determine spacing. Verify carriage wheels are centered in the channels and in the track.
- The tracks must be parallel, level and square to each other to ensure proper operation. Measure each set of tracks and the entire system, corner to corner, to verify that each distance is the same. Once each cross measurement is the same, the system is square and parallel.
- When the tracks are square, parallel, level and shimmed as required drill the end holes. Install the remaining anchors. It is the installer's responsibility to verify smooth operation of the system.
- Place the remaining carriages on the track, verify smooth operation and install the remaining end stop on the MLTA track.

- Install the shelving per the manufacturer's specs, secure to the mobile carriage with tek screws, through corners/center plates. Tek screws found in accessory box.

NOTE: KWIK FILE LATERAL FILE CABINETS REQUIRE THE REMOVAL OF LEVELERS FOR ALL UNITS THAT ARE PLACED ONTO A KWIK TRACK CARRIAGE.

