

Kwik-File, LLC

Mailflow-To-Go VertiPocket Combination Sorter SRFC3871

VertiPocket Combination Sorter

Model SRFC3871, 37 3/4"W x 12 3/4"D x 71"H

Parts list and drawings for SRFC3871

Mailflow-To-Go VertiPocket Sorter.

Note: Upper and Lower End Panels are the same height. The upper end panel is 1/16" wider than the Lower End Panel.

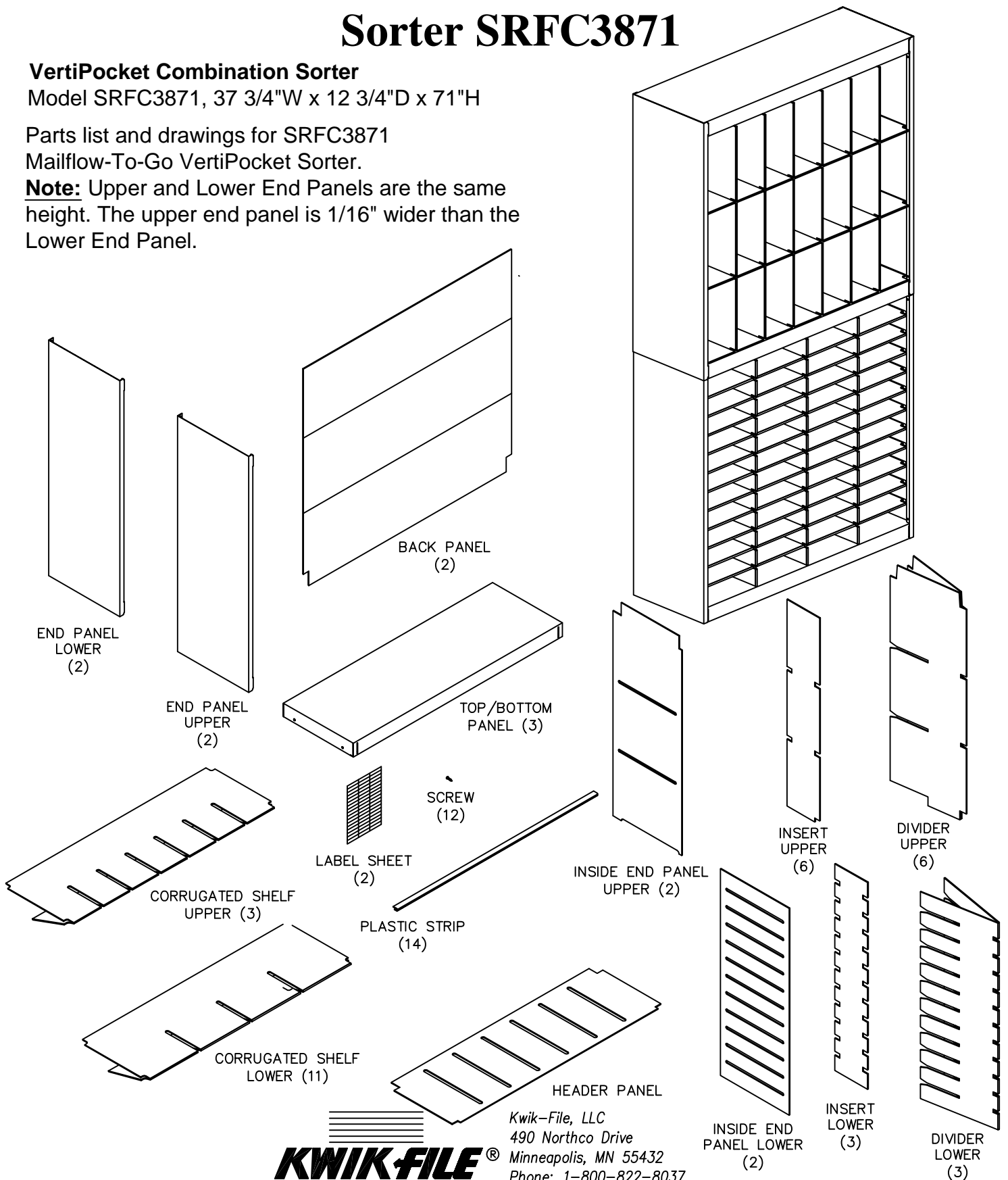

KWIK-FILE®

Kwik-File, LLC
490 Northco Drive
Minneapolis, MN 55432
Phone: 1-800-822-8037
Fax: 920-457-7388
Online: www.mayline.com

1. Tools required: Phillips screwdriver. Unpack carton; then identify and count all parts.

2. Place a 2" thick shelf with open side down on the floor; front edge has slots at each end. Install lower outside end panels (1/16" thinner than upper outside end panels): insert tab through slot in front as shown, and turn back of end panel until it fits behind back of shelf. Repeat with other side. Insert 4 screws through outside end panel and shelf at rear corners; fasten securely.

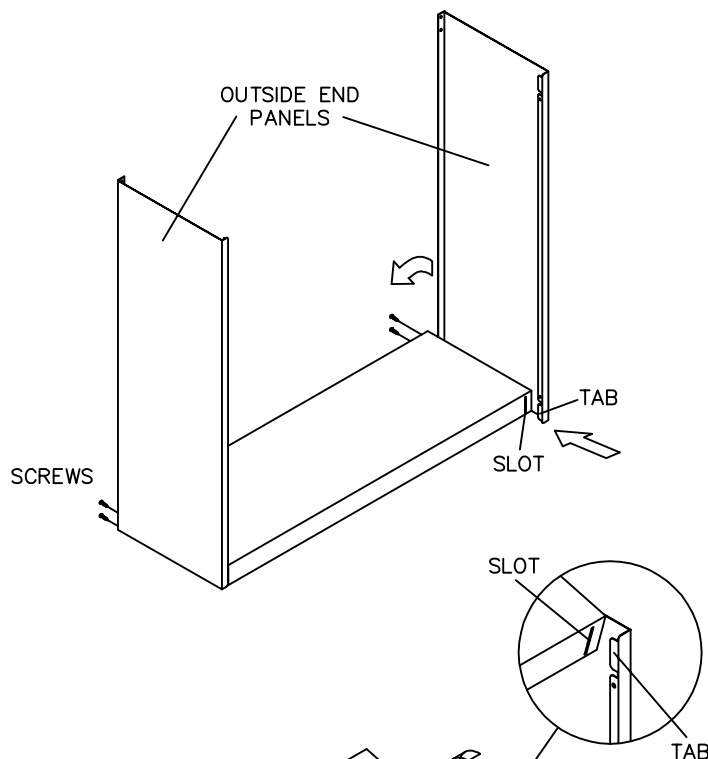

3. Install top 2" thick shelf by sliding onto tabs of outside end panels. Pull out the back edges of the outside end panels so the shelf can be lowered into place; then return outside end panels to their original position.

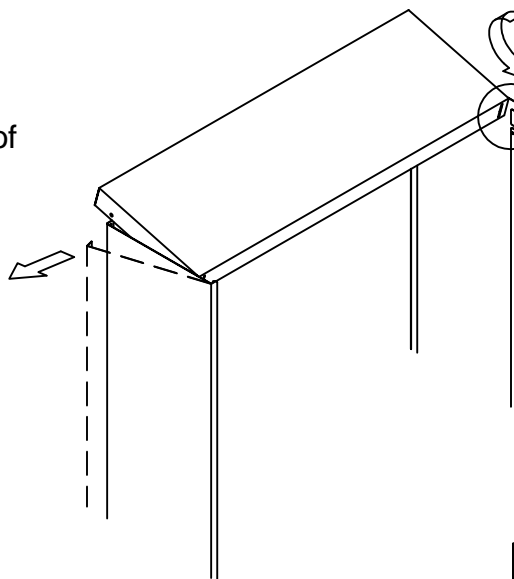

4. Assemble upper level by installing upper outside end panel. Insert tab at bottom front of panel into same shelf slot used by lower outer end panel; then move back of upper end panel until it fits behind back of shelf. Now insert two screws; repeat with opposite panel. Install top shelf as before; insert 4 screws (through spacers for added depth and better fit); fasten securely.

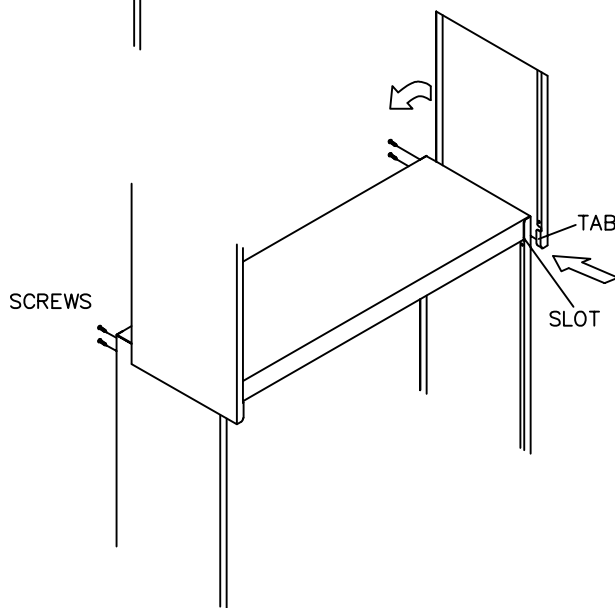

5. Now that both lower and upper levels have been combined into one large organizer, carefully place the unit on its back. Insert both lower and upper fiberboard back panels; then insert inside header panel (with 6 slots) with large corner cutouts toward back of unit (upper level only).

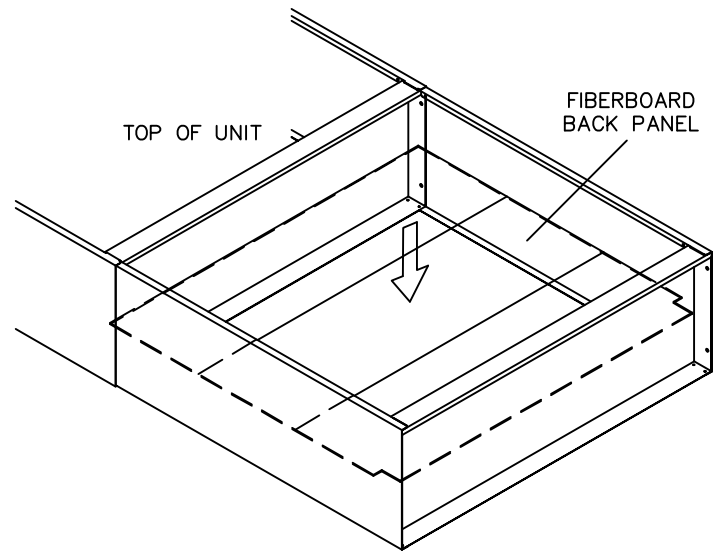

6. Install corrugated inside end panels with feet on bottom and large corner cutout to top rear of sorter, and 3 shelf slots, in upper level only; install corrugated inside end panels with 11 shelf slots in lower level. Press inside end panels firmly against outside end panels, making sure that they are tight against the bottom shelf (lower level only).

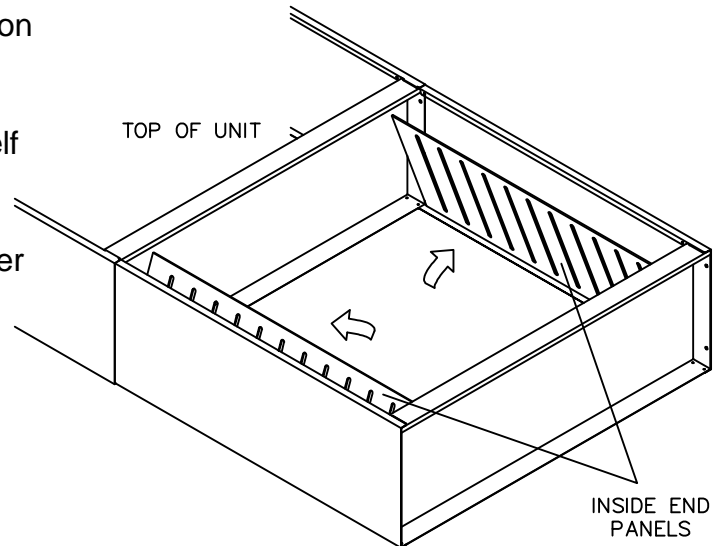

7. Install one corrugated shelf into the slots in the inside end panels, with the short folded side of the shelf on the bottom. Repeat with the remaining shelves in both upper and lower levels, ending with the last shelf in upper level resting on the bottom of that level.

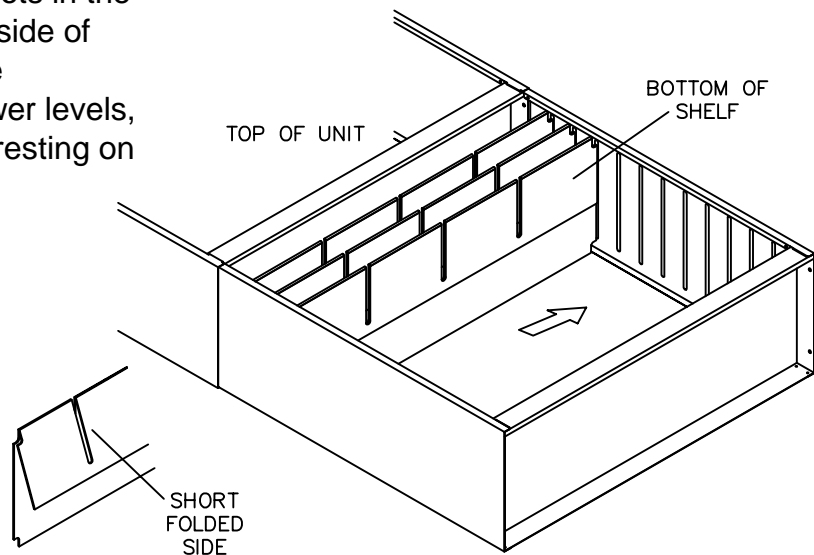

8. Upper Level: Place a corrugated insert (with notch at the bottom front) into a corrugated divider. Fold small flaps at bottom of divider outwards. Install corrugated dividers (6 in all), making sure the folded flaps fit under bottom shelf, and top of divider fits into slots in header panel. Press divider down firmly until flush with shelves.

Lower Level: Place corrugated insert into corrugated divider. Then install corrugated dividers (3 in all) into slots in shelves in lower level, pressing down firmly until flush with shelves.

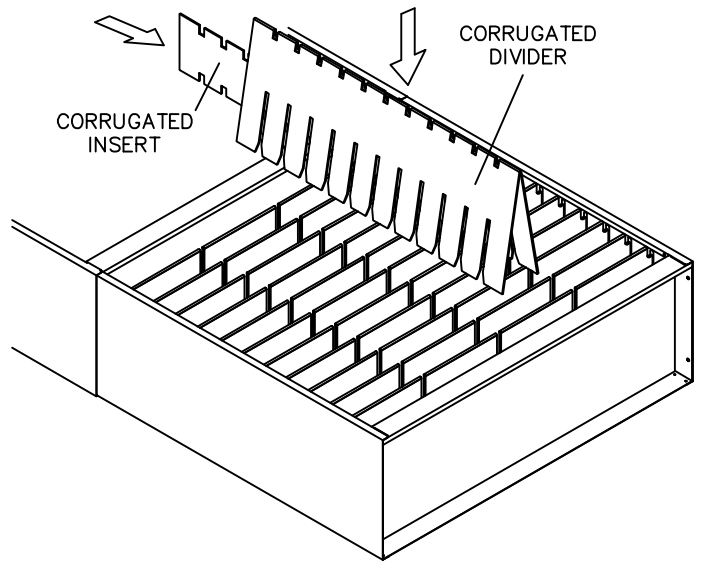

9. Install plastic strips on front edge of each shelf, with the short edge of the plastic strip under the bottom, and the longer edge over the shelf top. Roll each strip onto the shelf edge and press firmly into place. Repeat for all shelves.

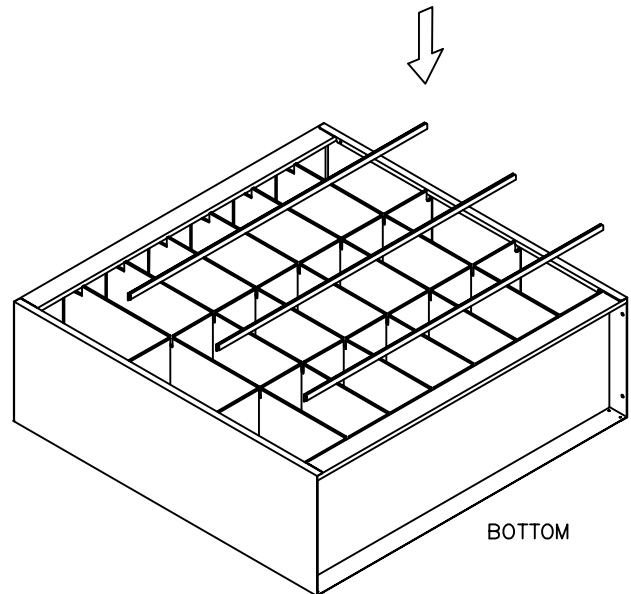
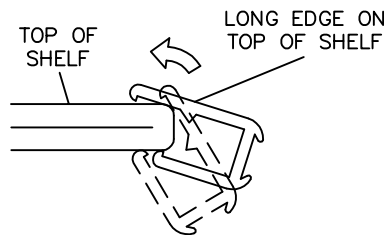

10. The grooves in the front of each plastic strip hold the paper labels provided. Separate each label along the perforations; then insert in the bottom groove, and push the label into place, tucking the top of label into the top groove with your fingernail. (Labels can be created using a PC and printer or typewriter as desired, but before separating.)

