

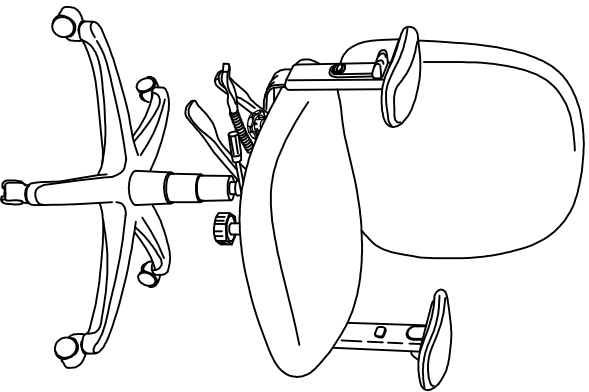



ASSEMBLY INSTRUCTIONS
MERCADO TASK CHAIR
MODEL NO. TC2250



PARTS LIST TC2250

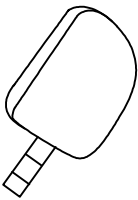

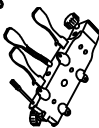
When ordering components, specific color and/or size information may be required.
 Contact a Mayline Customer Service Representative. 1-800-822-8037

* Individual Items, Order by part number.
 ** Denotes Color Code



Reference Letter A*		Quantity 1
Part Number CM111** Back		
Reference Letter B*		Quantity 1
Part Number CM130** Seat		
Reference Letter C*		Quantity 1
Part Number CM149** Arms (pair)		
Reference Letter D*		Quantity 1
Part Number CM161 Mechanism		
Reference Letter E*		Quantity 5
Part Number CM210 Caster (5 pack)		
Reference Letter F*		Quantity 1
Part Number CM202 Base		

Reference Letter G*		Quantity 1
Part Number CM182 Cylinder		
Reference Letter H*		Quantity 1
Part Number CM191 Cylinder Cover		

Part Number CM225 * Hardware Pack			
Reference Letter J		Quantity 4	Spare 1
Reference Letter K		Quantity 2	
Reference Letter L		Quantity 1	

IMPORTANT!

Review ALL instructions before beginning assembly. These instructions are provided to avoid problems that may occur from improper assembly or installation. Mayline and/or its distributor are not responsible for failure resulting from improper assembly or installation of this product. Moreover, all warranties are void for failure to follow these assembly instructions.



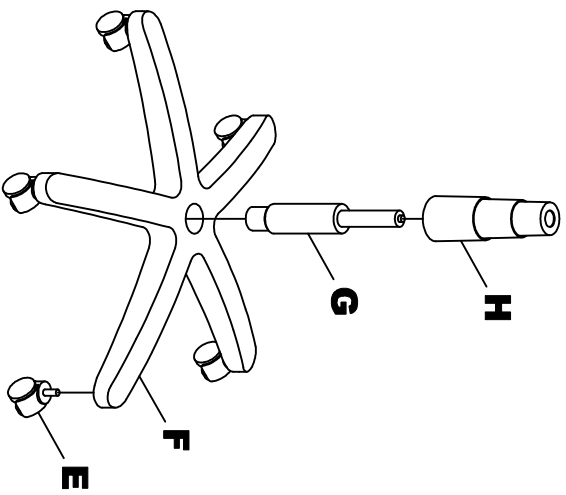

1. Place Base (F) upside down and push Casters (E) firmly into base. 5 places.
2. Turn Base right side up and insert Cylinder (G) into center hole of Base.
3. Place Cylinder Cover (H) over Cylinder.

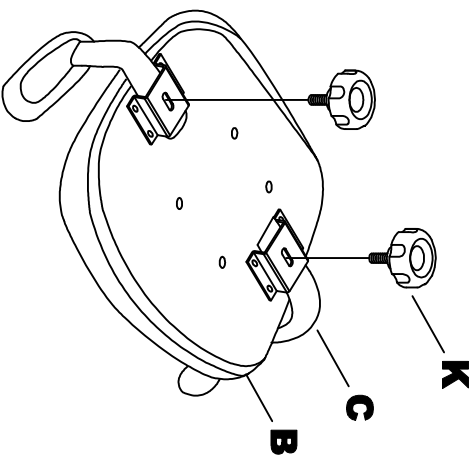

4. Assemble Arms (C) onto Seat (B) using Knobs (K) 2 places.

(3)

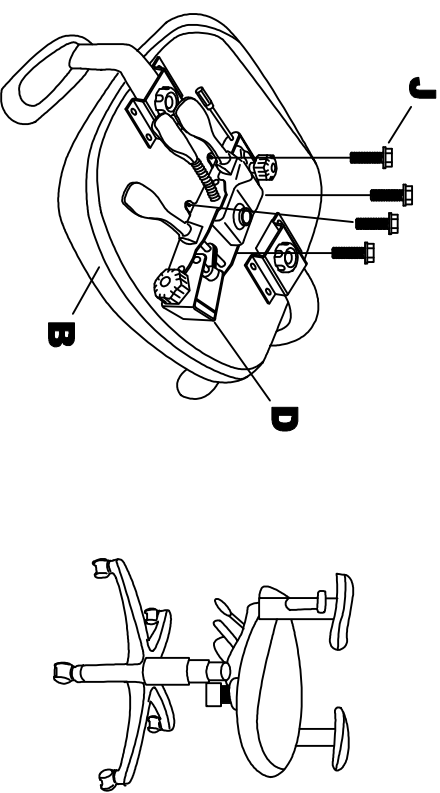

5. Assemble Mechanism (D) onto Seat (B) using Screws (J) 4 places.
6. Carefully place seat assembly onto base assembly.

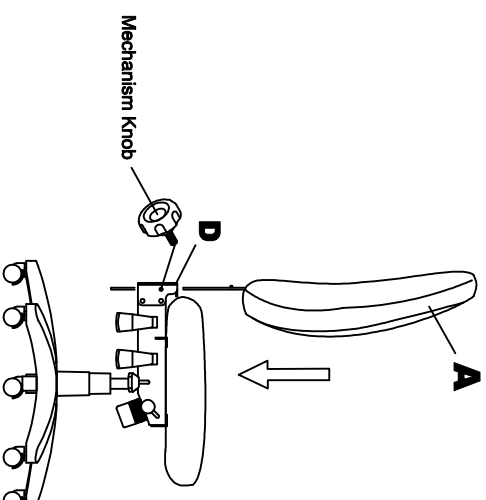

7. Loosen Mechanism Knob. Insert Back (A) into Mechanism (D).
8. Adjust Back to desired height and tighten Knob.

NOTE:
Periodically (Every 90 days) make sure screws are fully tightened.

(4)

OPERATING INSTRUCTIONS FOR MULTI-FUNCTION MECHANISM

- 1. Back Height Control Knob.**
To raise the back, loosen knob and lift back upward, tighten knob.
- 2. Back Posture Adjustment**
To adjust angle of the back, pull paddle up.
Adjust back, push knob down to lock.
- 3. Seat Height Adjustment.**
To raise the seat, pull lever upward and raise your body up slightly to allow the chair to rise to the desired height.
To lower the seat, pull lever upward and apply weight downward on the seat.
- 4. Seat Posture Adjustment**
To adjust angle of the seat, pull paddle up.
Adjust seat, push knob down to lock.

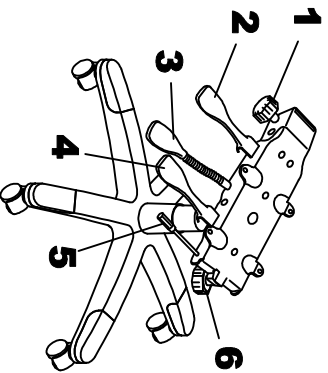

Note: To operate items 5 & 6, Item 3 must be unlocked (up position).

- 5. Seat Angle.**
To lock chair in upright position, lean backward and push knob toward chair.
To unlock chair in upright position, lean backward and pull away from chair.
- 6. Tilt Tension Control Knob.**
Turn knob clockwise to increase tilt tension.
Turn knob counter-clockwise to decrease tilt tension.

