

ASSEMBLY INSTRUCTIONS

Mercado Traditional Guest Chair

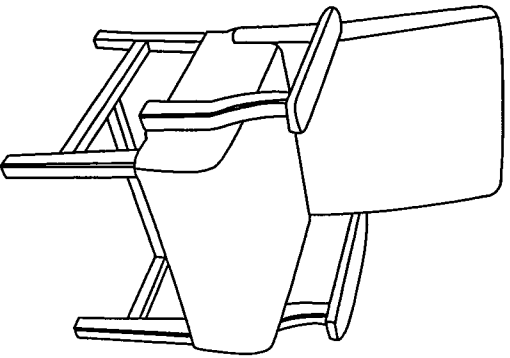







Model No. TSGST

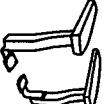

PARTS LIST TSGST

When ordering components, specific color and/or size information may be required. Contact a Mayline Customer Service Representative. 1-800-822-8037

* Individual Items, Order by part number.
 ** Denotes Color Code.

Reference Letter	Quantity	Spare
A* Part Number 101556** Back Reference Letter	 1	
B* Part Number 101557** Seat Reference Letter	 1	
C* Part Number 101551** Arms (pair) Reference Letter	 2	
Part Number * 101546 Hardware Bag		
D Reference Letter Screw 1/4-20 x 1"	 12	1
E Reference Letter Screw 1/4-20 x 1-1/4"	 4	1
F Reference Letter Screw 1/4-20 x 1-1/2"	 2	
G* Part Number 101547 Arm Bracket Reference Letter	 2	
H Reference Letter Allen Wrench	 1	

1



Tiffany Industries™

A MAYLINE GROUP COMPANY

619 N. Commerce, P.O. Box 728
 Sheboygan, WI 53082-0728

Toll Free: 1-800-822-8037
 FAX: 920-457-7388
 On Line: www.mayline.com

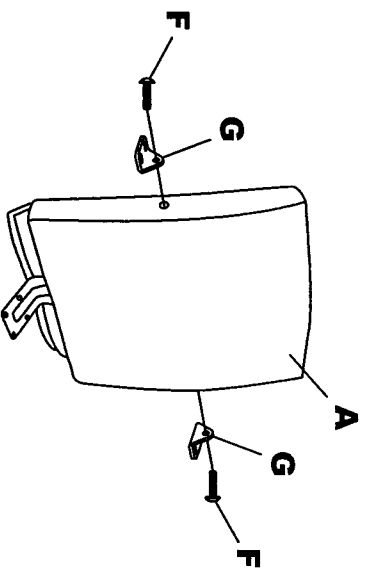

1. Assemble Arm Bracket (G) onto Back (A) using Screws (F) 2 places.

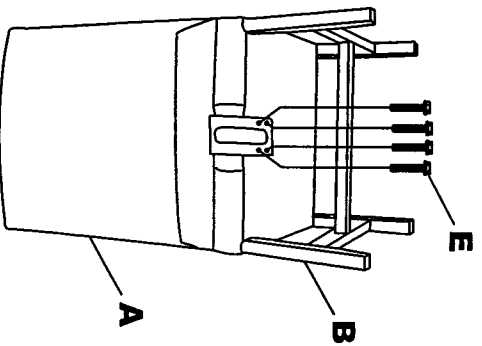

2. Assemble Back (A) onto Seat (B) using Screws (E) 4 places.

2

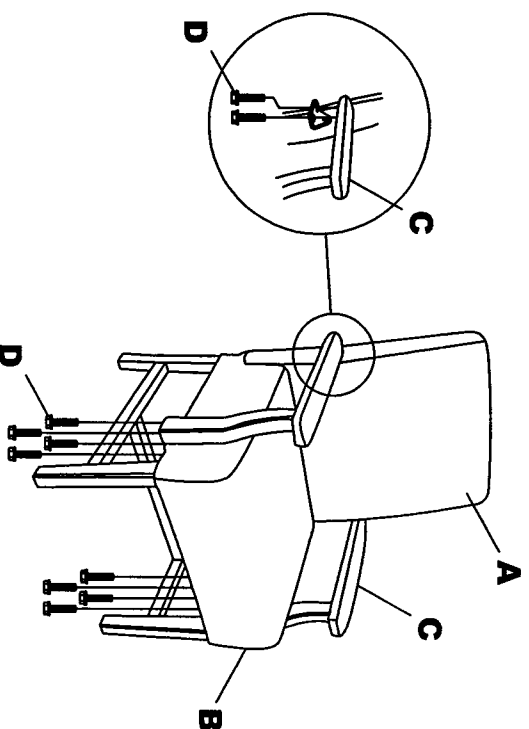

3. Assemble Arms (C) 2 places onto Seat (B) using Screws (D) 8 places.
DO NOT TIGHTEN SCREWS at this time.

4. Assemble Arms (C) 2 places onto Back (A) using Screws (D) 4 places.
DO NOT TIGHTEN SCREWS at this time.

5. After both arms are installed tighten all Screws (D) 12 places.

NOTE:
Periodically (Every 90 days) make sure screws are fully tightened.

3