

**Tiffany Industries™**  
A MAYLINÉ GROUP COMPANY

# Club Chair

## Model No. VCC1BLK

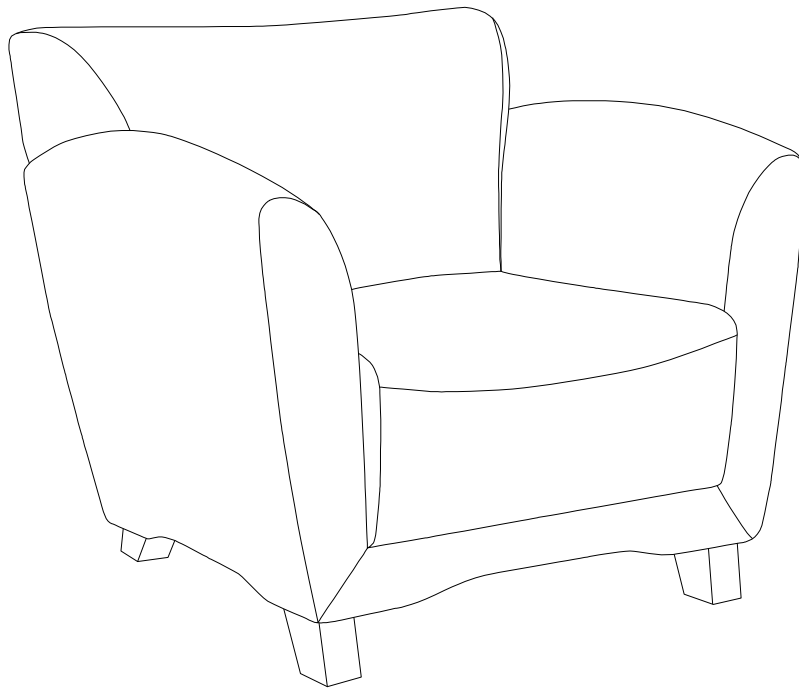



# ASSEMBLY INSTRUCTIONS

## CALL 1-800-822-8037 FOR ASSISTANCE

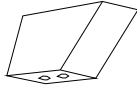
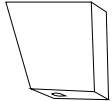
# PARTS LIST

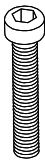
Name	Part	Qty.	Spare Qty
<b>A*</b>	 <b>VCC1BLK</b> Club Chair	<b>1</b>	
<b>B*</b>	 <b>VCCLEG**</b> Back Leg	<b>2</b>	
<b>C*</b>	 <b>VCCLEG**</b> Front Leg	<b>2</b>	

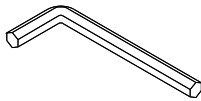
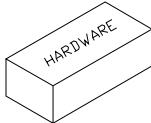
Name	Part	Qty.	Spare Qty
<b>D</b>	 <b>REALS094</b> M8x60mm <b>HB</b>	<b>8</b>	
<b>E</b>	 <b>REALS096</b> 15mmx8.5mm <b>HB</b>	<b>8</b>	
<b>F</b>	 <b>REALS084</b> Allen Wrench <b>HB</b>	<b>1</b>	
	 <b>VCCHB</b>		

Items with HB are in hardware box.  
 \*For Individual Items, Order By Part Number.  
 \*\*Denotes Color Code

**1**

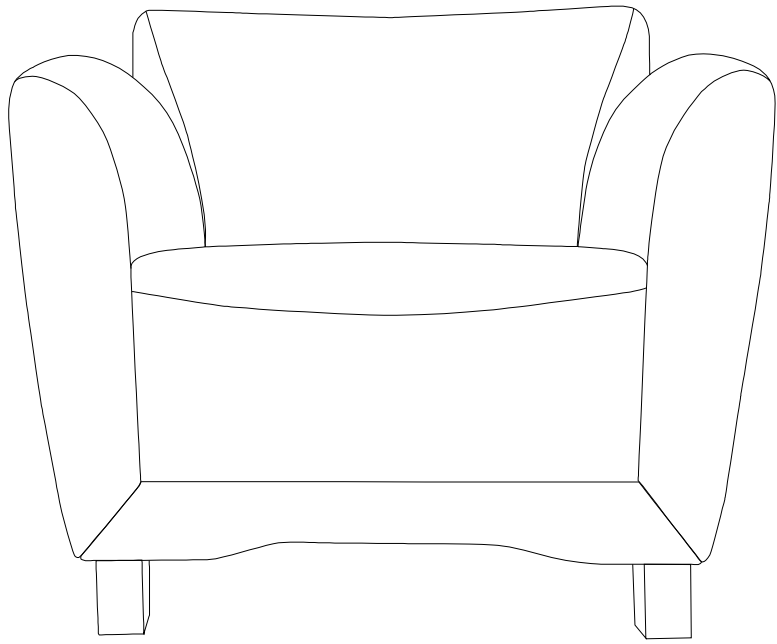
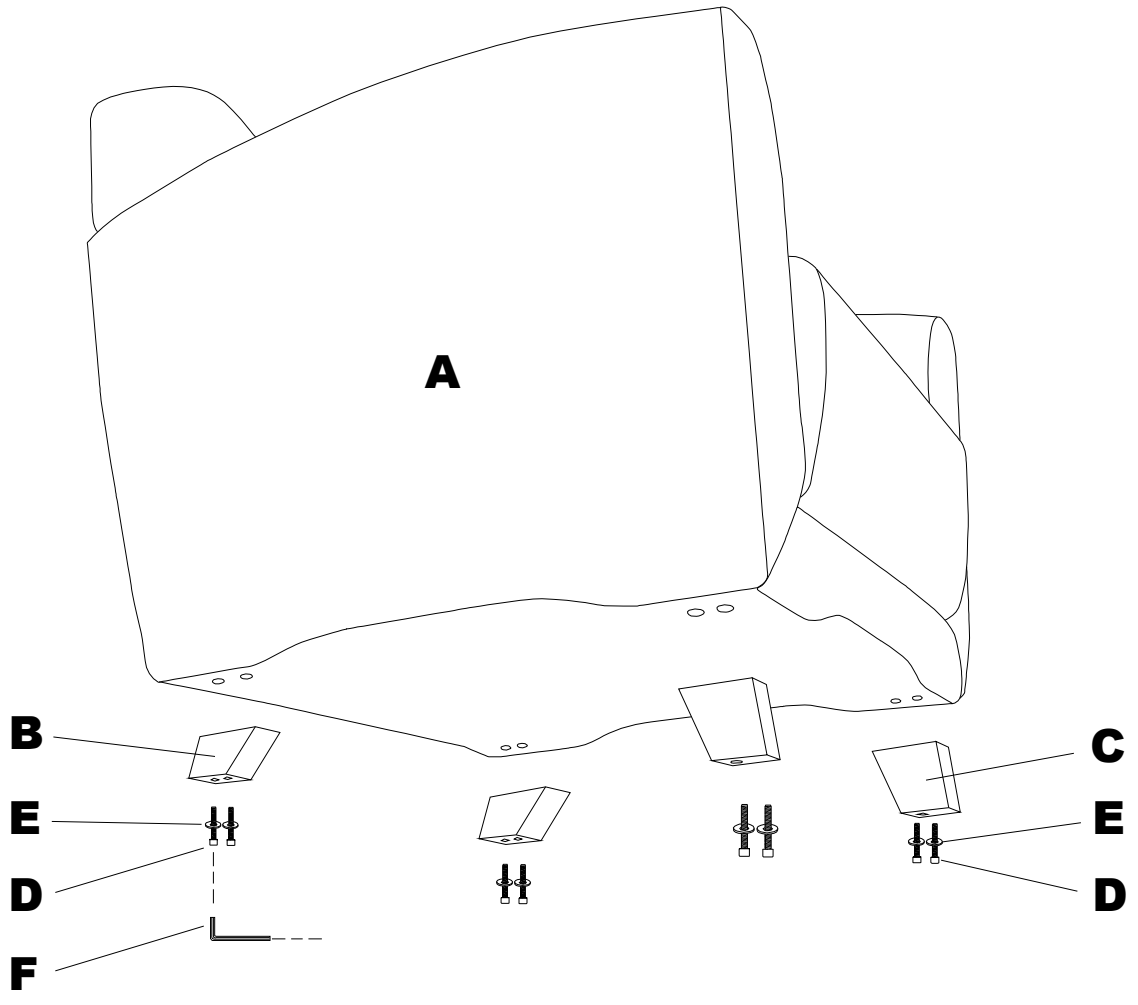

**2**