

ASSEMBLY INSTRUCTIONS

Mercado Guest Chair

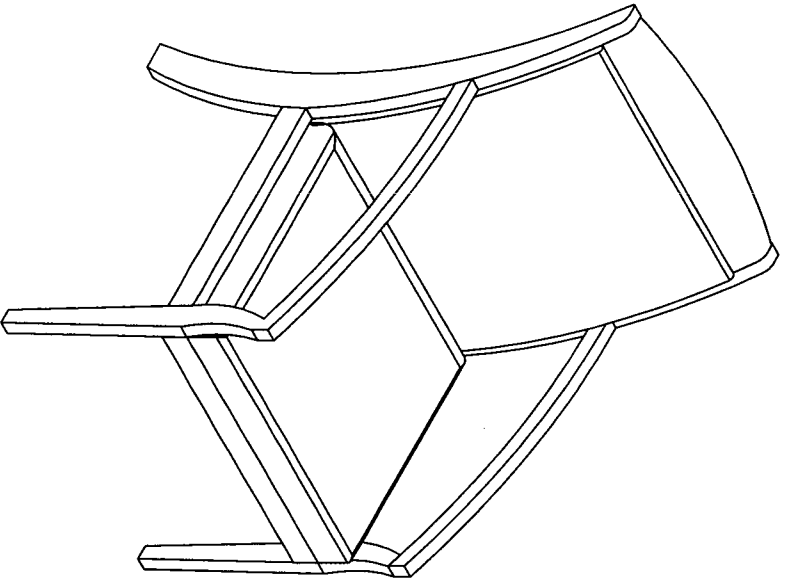









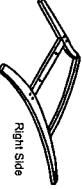

Model No. VSC



PARTS LIST

When ordering components, specific color and/or size information may be required.
Contact a Mayline Customer Service Representative. 1-800-822-8037

* Individual Items. Order by part number.
** Denotes Color Code.

Reference Letter	A *		Quantity	1	Spare	
Reference Letter	B *		Quantity	1	Spare	
Part Number	101513** Legs (pair)					
Reference Letter	C *		Quantity	1	Spare	
Part Number	VSCC** Back Support					
Reference Letter	D *		Quantity	1	Spare	
Part Number	101514** Frame					
Reference Letter	G *		Quantity	1	Spare	
Part Number	VSCG Back					
Reference Letter	H *		Quantity	1	Spare	
Part Number	VSCH Seat					
Part Number	101509* Hardware Bag					
Reference Letter	J		Quantity	1	Spare	
Reference Letter	K		Quantity	2	Spare	1
Reference Letter	L		Quantity	2	Spare	1
Reference Letter	M		Quantity	4	Spare	1
Reference Letter	N		Quantity	8	Spare	1
Reference Letter	P		Quantity	1	Spare	
Reference Letter	R		Quantity	12	Spare	
Reference Letter						1



Tiffany IndustriesTM

A MAYLINE GROUP COMPANY

619 N. Commerce, P.O. Box 728
Sheboygan, WI 53082-0728

Toll Free: 1-800-822-8037
FAX: 920-457-7388
On Line: www.mayline.com

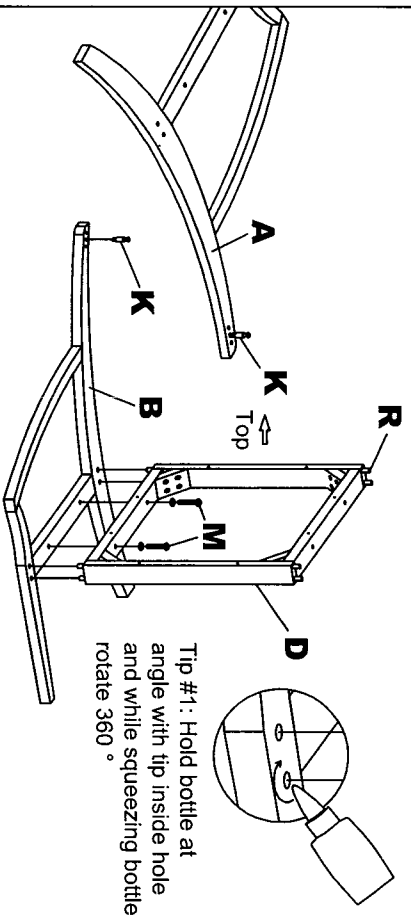

1. Attach Cam Post (K) to Legs (A) & (B) by hand until black plastic contacts frame. Do Not Overtighten.
2. Apply glue into dowel holes on Legs (A) & (B) 6 places each leg. See tip #1.
3. Locate top of Frame (D) and assemble to Leg (B). Make sure all dowels are inserted and parts are flush. Attach Frame & Leg using Screw & Washer (M) 2 Places. Do Not Tighten at this time.

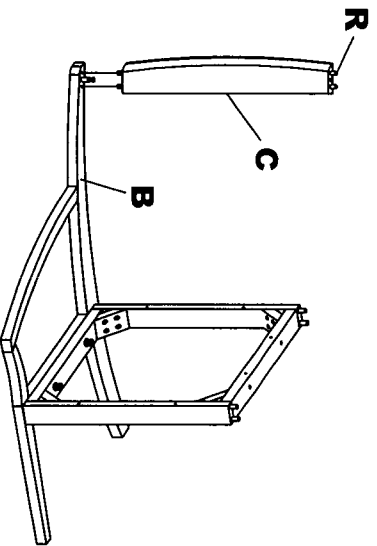

4. Assemble Back Support (C) to Leg (B). Make sure all dowels are inserted and parts are flush.

2

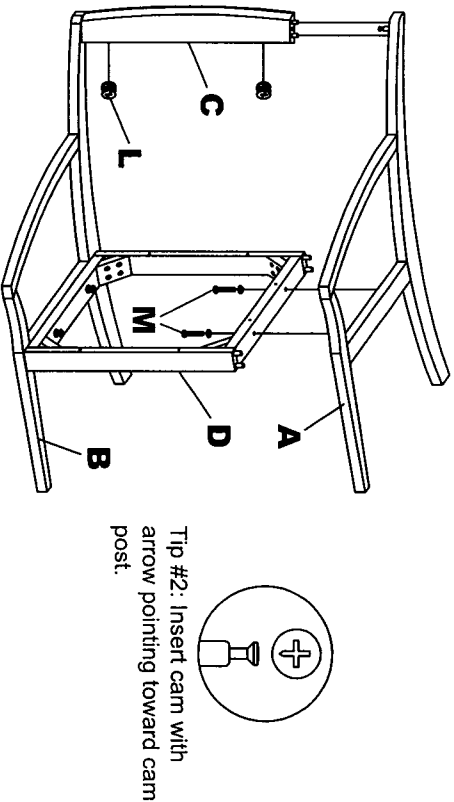

5. Assemble Leg (A) to Frame (D) & Back Support (C). Make sure all dowels are inserted and parts are flush. Attach Leg to Frame using Screw & Washer (M) 2 Places. Do Not Tighten at this time.
 6. Attach Legs (A) & (B) to Back Support (C) using Cam (L) 2 Places. See tip #2. Make sure Cam (L) are tight (between 3/8 - 1/2 turn). Do not force as you may break the cam.
- Troubleshooting: Disengage cam lock, separate pieces and turn cam post approx. 1/4 turn counter-clockwise. repeat step 4 until cam lock is tight.

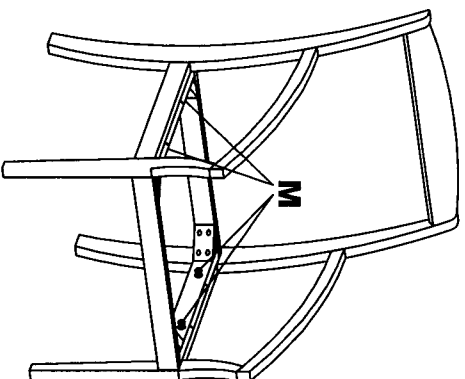

7. Place chair on level surface and tighten Screws (M).

3

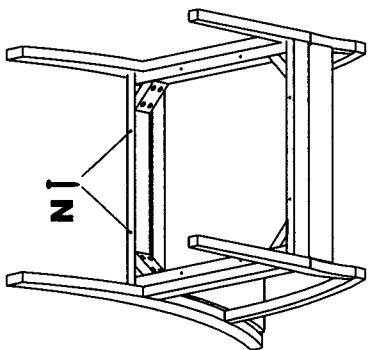
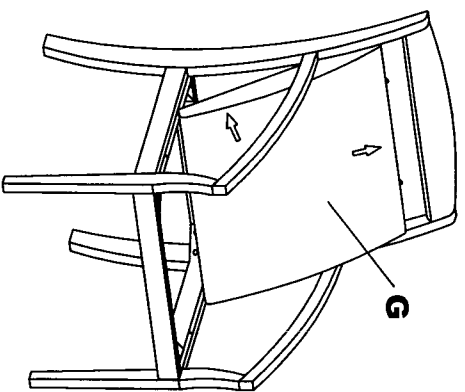

8. Assemble Back Cushion (G) by pushing up until wood dowels engage slots in back support. Rotate bottom of seat back until the bead of the cushion contacts the arms.

9. Attach back to frame using Screws (N) 2 places.

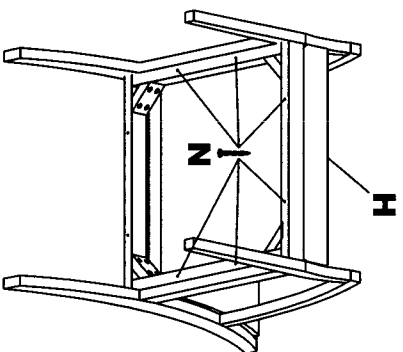

10. Assemble Seat Cushion (H) by placing seat on frame and push back until it fits tightly with back cushion. (Front of cushion will overhang frame)

11. Attach seat to frame by using Screws (N) 6 places. Apply pressure to the top of seat while attaching screws.