

# ASSEMBLY INSTRUCTIONS

## Mercado Guest Chair

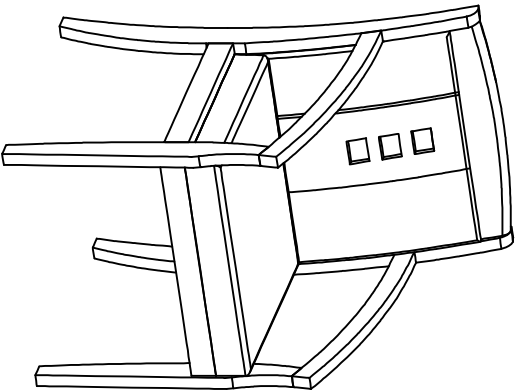

### Model No. VSC2









## PARTS LIST VSC2

When ordering components, specific color and/or size information may be required.  
Contact a Mayline Customer Service Representative. 1-800-822-8037

\* Individual Items, Order by part number.  
\*\* Denotes Color Code.

Reference Letter	Quantity
<b>A *</b> Reference Letter  Left Side	<b>1</b>
<b>B *</b> Reference Letter  Right Side	<b>1</b>
<b>Part Number</b> <b>101500**</b> Legs (pair)	
Reference Letter	
<b>C *</b> Part Number 101503** Back Support	<b>1</b>
Reference Letter	
<b>D *</b> Part Number 101502** Frame	<b>1</b>
Reference Letter	
<b>E *</b> Part Number 101491** Seat	<b>1</b>

Part Number	Quantity	Spare
<b>101544*</b> Hardware Bag		
Reference Letter		
<b>F</b> Reference Letter Screw M8 x 50mm 	<b>1</b>	
Reference Letter		
<b>G</b> Reference Letter Screw M4 x 40mm 	<b>4</b>	<b>1</b>
Reference Letter		
<b>H</b> Reference Letter Cam 	<b>4</b>	<b>1</b>
Reference Letter		
<b>J</b> Reference Letter Cam Post 	<b>6</b>	<b>1</b>
Reference Letter		
<b>K</b> Reference Letter Glue 	<b>8</b>	<b>1</b>
Reference Letter		
<b>L</b> Reference Letter Allen Wrench 	<b>1</b>	

Pre-Assembled	Quantity
Reference Letter <b>M *</b> Dowel S004 	<b>12</b>

**1**

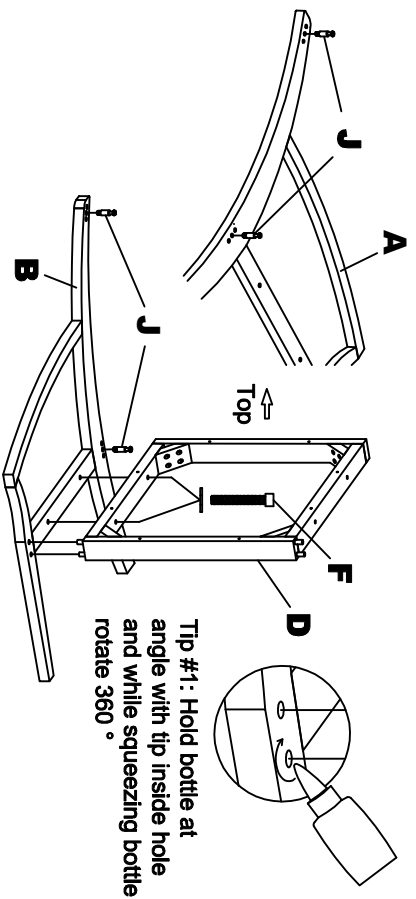

1. Attach Cam Post (J) to Legs (A & B) by hand until black plastic contacts frame. 2 places per leg. Do Not Overtighten.
2. Apply glue into dowel holes on Legs (A & B) 6 places each leg. See tip #1.
3. Locate top of Frame (D) and assemble to Leg (B). Make sure all dowels are inserted into holes and parts are flush. Attach Frame & Leg using Screw & Washer (F) 2 Places. Do Not Tighten at this time.

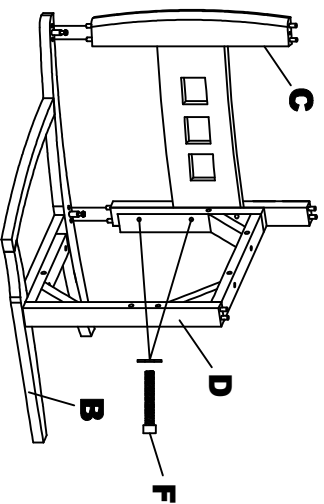

4. Assemble Back (C) to Leg (B). Make sure all dowels are inserted into holes and parts are flush.
5. Attach Back Support (C) to Frame (D) using Screw & Washer (F) 2 Places. Do Not Tighten at this time.

**2**

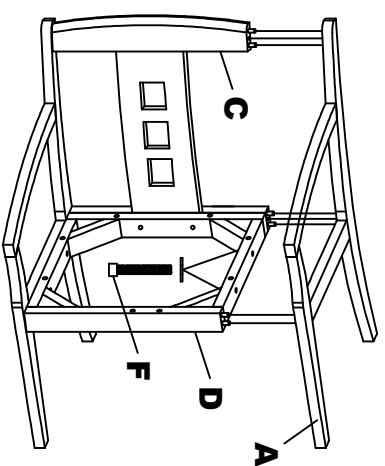

6. Assemble Leg (A) to Frame (D) & Back (C). Make sure all dowels are inserted into holes and parts are flush. Attach Leg to Frame using Screw & Washer (F) 2 Places. Do Not Tighten at this time.

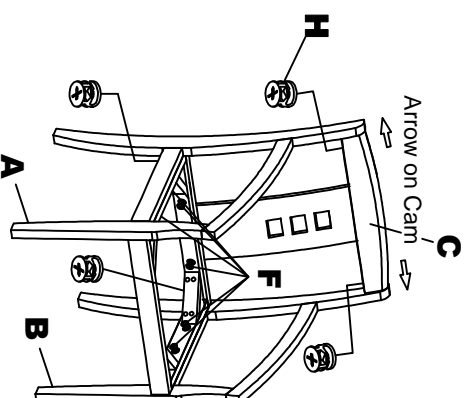

Tip #2: Insert cam with arrow pointing toward cam post.

7. Place chair on level surface and tighten all Screws (F) 6 Places.
8. Attach Legs (A&B) to Back (C) using Cambs (H) 4 Places. See tip #2. Make sure Cambs are tight by rotating cambs clockwise (between 3/8 - 1/2 turn). Do not force as you may break the cam.

**3**

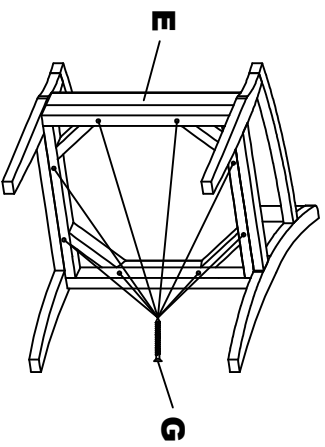

9. Assemble Seat Cushion (E) by placing seat on frame and push back until it fits tightly with back. (Front of cushion may overhang frame)
10. Attach seat to frame by using Screws (G) 8 places. Apply pressure to the top of seat while attaching screws.