

ASSEMBLY INSTRUCTIONS

Mercado Wood Guest Chair

Model No. VSC4

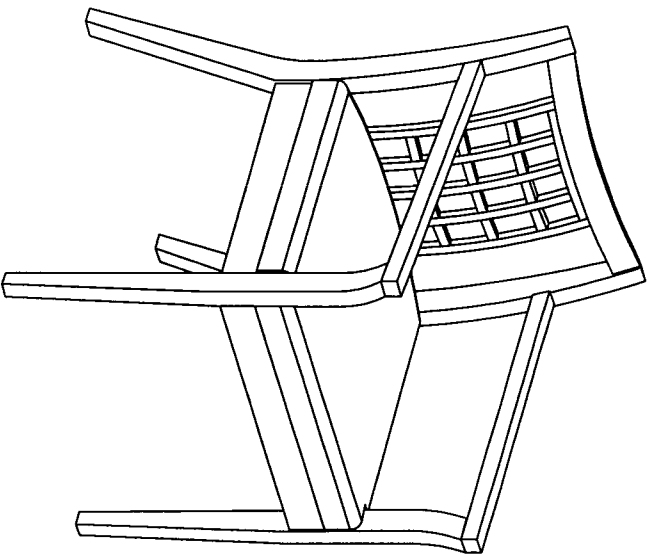

PARTS LIST

When ordering components, specific color and/or size information may be required.
Contact a Mayline Customer Service Representative. 1-800-822-8037

* Individual Items. Order by part number.
** Denotes Color Code.

Reference Letter	Quantity	Spare
A *	1	1
Part Number 101533** Arms (pair)		
B *	2	1
Reference Letter		
Part Number 101534** Back		
C *	1	1
Reference Letter		
Part Number 101535** Frame		
D *	1	1
Reference Letter		
Part Number 101536 Seat		
101528* Hardware Bag		
E	2	1
Reference Letter		
Screw M8 x 50mm		
F	4	1
Reference Letter		
Screw M8 x 55mm		
G	4	1
Reference Letter		
Screw M8 x 70mm		
H	9	1
Reference Letter		
Screw M4 x 40mm		
J	2	1
Reference Letter		
Pin		
K	2	1
Reference Letter		
Barrel Nut w/Set Screw		
L	1	
Reference Letter		
Allen Wrench		

1



Tiffany Industries™

A MAYLINE GROUP COMPANY

619 N. Commerce, P.O. Box 728
Sheboygan, WI 53082-0728

Toll Free: 1-800-822-8037
FAX: 920-457-7388
On Line: www.mayline.com

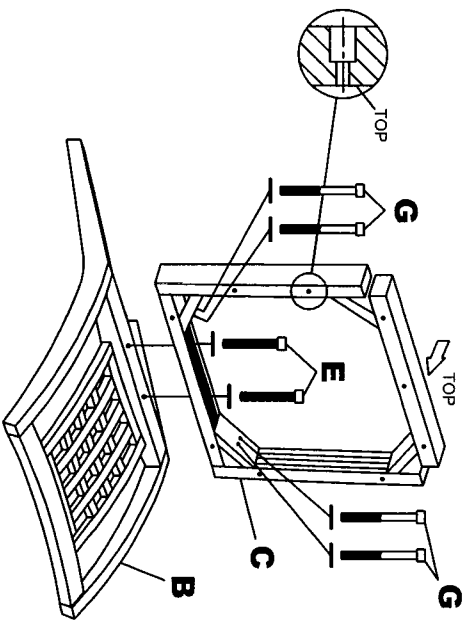

1. Locate top of Frame (C) (see sticker) and assemble to Back (B) using Screw & Washer (E) 2 Places and Screw & Washer (G) 4 Places. Do Not Tighten at this time.

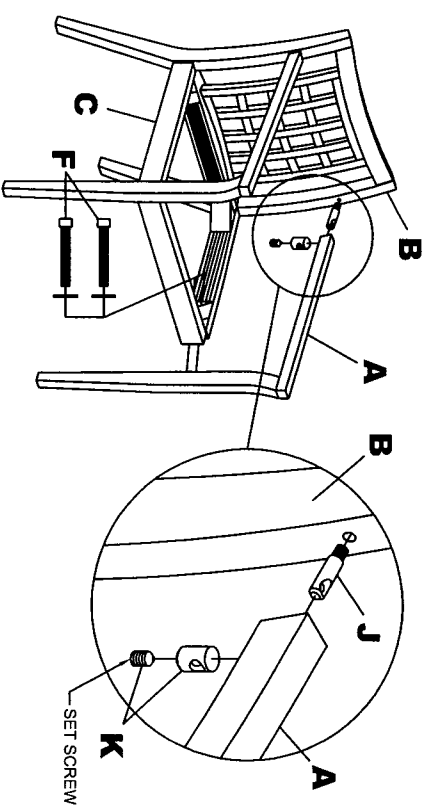

2. Hand tighten Pin (J) into Back (B) NOTE: align hole in pin to be up and down as shown, you may have to untighten slightly.
3. Remove Set Screw from Barrel Nut (K) and insert Barrel Nut into Arm (A) as shown. Attach arm by inserting Pin (J) into Barrel Nut (K) and attach using the Set Screw. Do Not Tighten at this time.
4. Assemble Arm (A) to Frame (C) using Screw & Washer (F) 2 places.
5. Repeat Steps 2-4 for other arm.

2

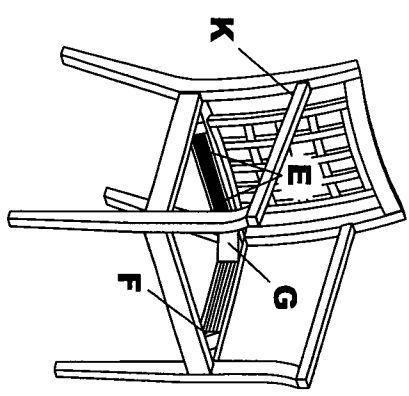

6. Place Chair on a flat level surface and Tighten all Screws, (E) 2 places, (F) 4 places, (G) 4 places. Do Not Overtighten Screws. Also tighten Set Screw (K) 2 places.

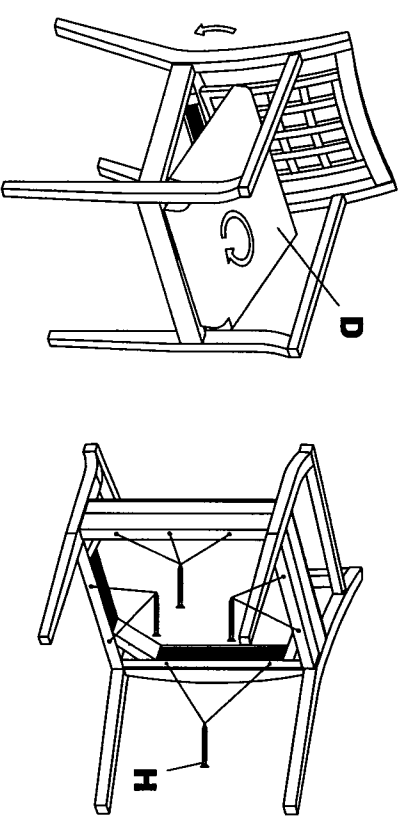

7. Install Seat (D) by rotating into place with front of seat angled down as shown. Gently push seat into place.
8. Attach seat to frame by using Screws (H) 9 places. Apply pressure to the top of seat while attaching screws.

3