

ASSEMBLY INSTRUCTIONS

Mercado Wood Guest Chair

Model No. VSC8

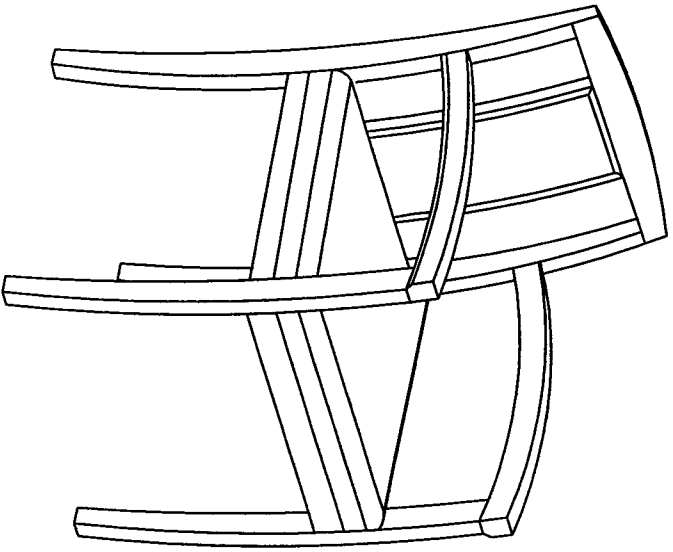

PARTS LIST

When ordering components, specific color and/or size information may be required. Contact a Mayline Customer Service Representative. 1-800-822-8037

* Individual items. Order by part number.
 ** Denotes Color Code.

Reference Letter A*		Quantity 1
Part Number 101560** Arms (pair)		
Reference Letter B*		Quantity 2
Part Number 101561** Back		
Reference Letter C*		Quantity 1
Part Number 101562** Frame		
Reference Letter D*		Quantity 1
Part Number 101563 Seat		

Part Number 101528* Hardware Bag			
Reference Letter E		Quantity 2	Spare 1
Screw M8 x 50mm			
Reference Letter F		Quantity 4	Spare 1
Screw M8 x 55mm			
Reference Letter G		Quantity 4	Spare 1
Screw M8 x 70mm			
Reference Letter H		Quantity 9	Spare 1
Screw M4 x 40mm			
Reference Letter J		Quantity 2	Spare 1
Pin			
Reference Letter K		Quantity 2	Spare 1
Barrel Nut w/Set Screw			
Reference Letter L		Quantity 1	Spare 1
Allen Wrench			

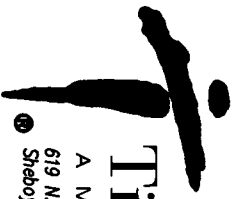

Tiffany Industries™

A MAYLINE GROUP COMPANY

619 N. Commerce, P.O. Box 728
 Sheboygan, WI 53082-0728

Toll Free: 1-800-822-8037
 FAX: 920-457-7388
 On Line: www.mayline.com

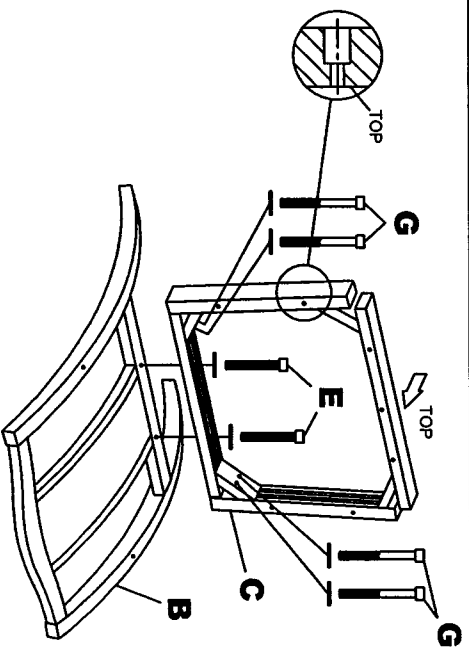

1. Locate top of Frame (C) (see sticker) and assemble to Back (B) using Screw & Washer (E) 2 Places and Screw & Washer (G) 4 Places. Do Not Tighten at this time.

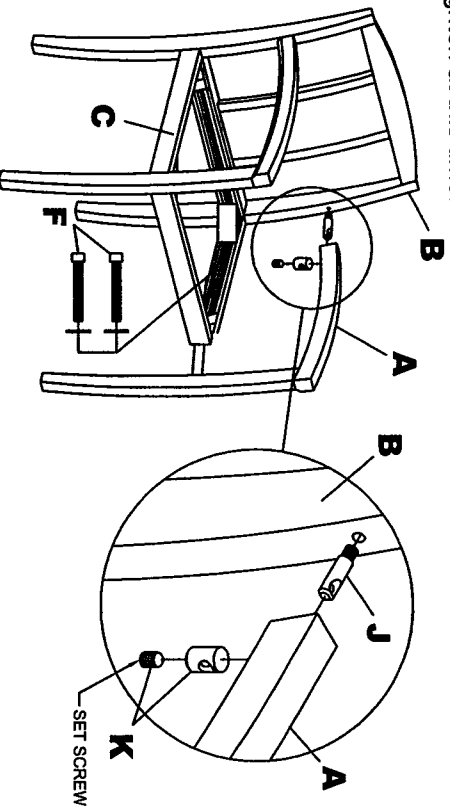

2. Hand tighten Pin (J) into Back (B) NOTE: align hole in pin to be up and down as shown, you may have to untighten slightly.
3. Remove Set Screw from Barrel Nut (K) and insert Barrel Nut into Arm (A) as shown. Attach arm by inserting Pin (J) into Barrel Nut (K) and attach using the Set Screw. Do Not Tighten at this time.
4. Assemble Arm (A) to Frame (C) using Screws (F) 2 places.
5. Repeat Steps 2-4 for other arm.

2

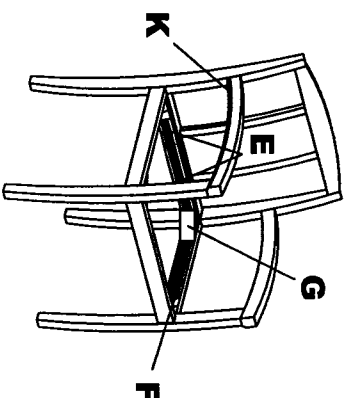

6. Place Chair on a flat level surface and Tighten all Screws, (E) 2 places, (F) 4 places, (G) 4 places. Do Not Overtighten Screws. Also tighten Set Screw (K) 2 places.

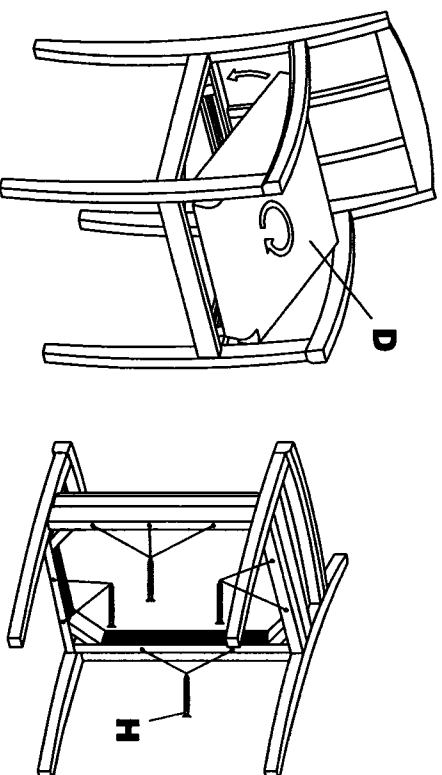

7. Install Seat (D) by rotating into place with front of seat angled down as shown. Gently push seat into place.
8. Attach seat to frame by using Screws (H) 9 places. Apply pressure to the top of seat while attaching screws.

3