

# **KWIK-FILE®**

## Cart, X-Ray File Model No. XC1010

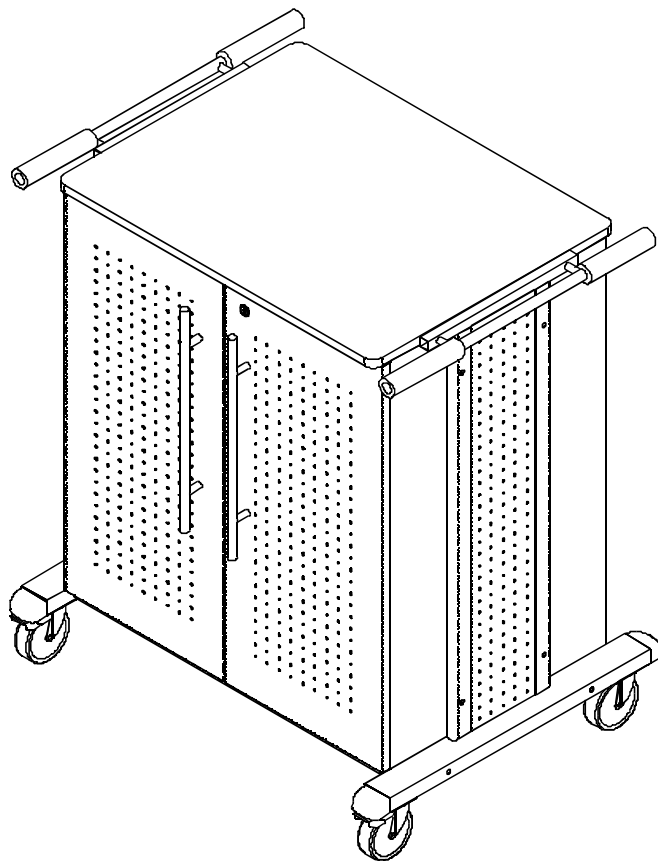

**ASSEMBLY INSTRUCTIONS**  
**CALL 1-800-822-8037 FOR ASSISTANCE**





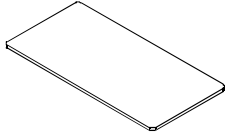
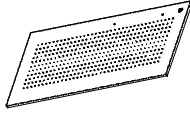
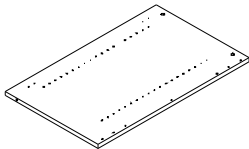
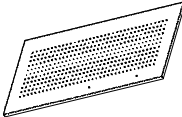
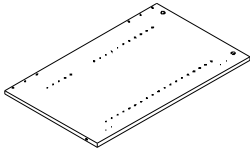
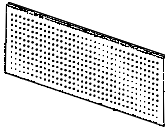
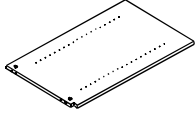
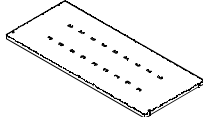
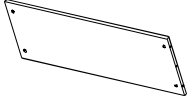
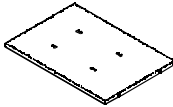
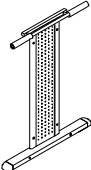
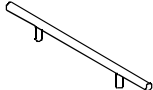
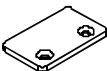

P/N **XC1010** REV 03 10/14/08



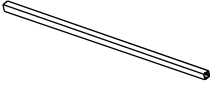

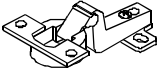

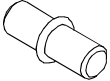
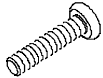

# PARTS LIST

Name	Part	Qty.	Name	Part	Qty.
<b>A</b>	 XC1010A Top	1	<b>F1</b>	 XC1010F1 Right Door	1
<b>B1</b>	 XC1010B1 Left Panel	1	<b>F2</b>	 XC1010F2 Left Door	1
<b>B2</b>	 XC1010B2 Right Panel	1	<b>G</b>	 XC1010G Metal Back Panel	1
<b>B3</b>	 XC1010B3 Center Panel	1	<b>H</b>	 XC1010H Bottom Panel	1
<b>C</b>	 XC1010C Wood Back Panel	2	<b>I</b>	 XC1010I Adjustable Shelf	2
<b>D</b>	 XC1010D Leg	2	<b>J2</b>	 XC1010J2 Door Handle	2
<b>E</b>	 HB Door Retainer	2			

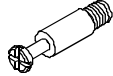
items with HB are in the hardware box.

# PARTS LIST

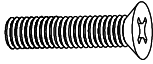
Name	Part	Qty.
<b>K</b>	 XC1010K Support Bar	<b>2</b>
<b>L</b>	 XC1010L Cross Bar	<b>1</b>
<b>M</b>	 XC1010M Folder Divider	<b>4</b>
<b>N</b>	 XC1010N Door Hinge	<b>4</b>
<b>O1</b>	 XC1010O1 Locking Caster	<b>2</b>
<b>O2</b>	 XC1010O2 Non Locking Caster	<b>2</b>
<b>P</b>	 HB Shelf Pin	<b>9</b>
<b>Q</b>	 HB 1/4 x 75mm	<b>5</b>
<b>S</b>	 HB 1/4 x 10mm	<b>27</b>

Name	Part	Qty.
<b>T</b>	 HB M4 x 10mm	<b>13</b>
<b>U</b>	 HB M4 x 15mm	<b>17</b>
<b>V</b>	 HB Cam Post	<b>15</b>
<b>W</b>	 HB Wood Dowel	<b>11</b>
<b>X</b>	 HB Cam Lock	<b>15</b>
<b>Y</b>	 HB Hex Wrench	<b>1</b>
<b>Z</b>	 HB XC1010Z-Leg Cap	<b>4</b>
<b>AA</b>	 HB 1/4-20 x 2" Flat HD	<b>8</b>
<b>AB</b>	 HB 1/4" x 1" Fender Washer	<b>8</b>
<b>AC</b>	 HB 1/4-20 Lock Nut	<b>8</b>

Items with HB are in the hardware box.

1

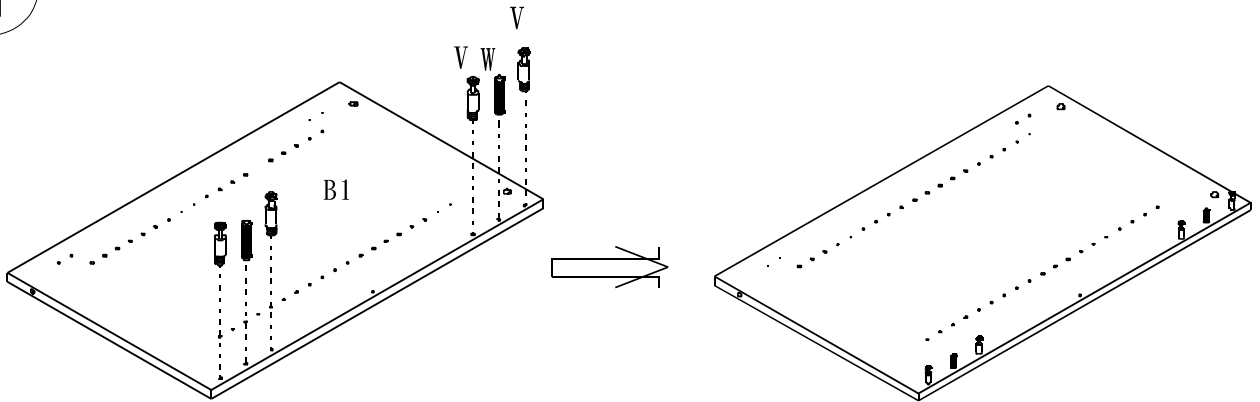

2

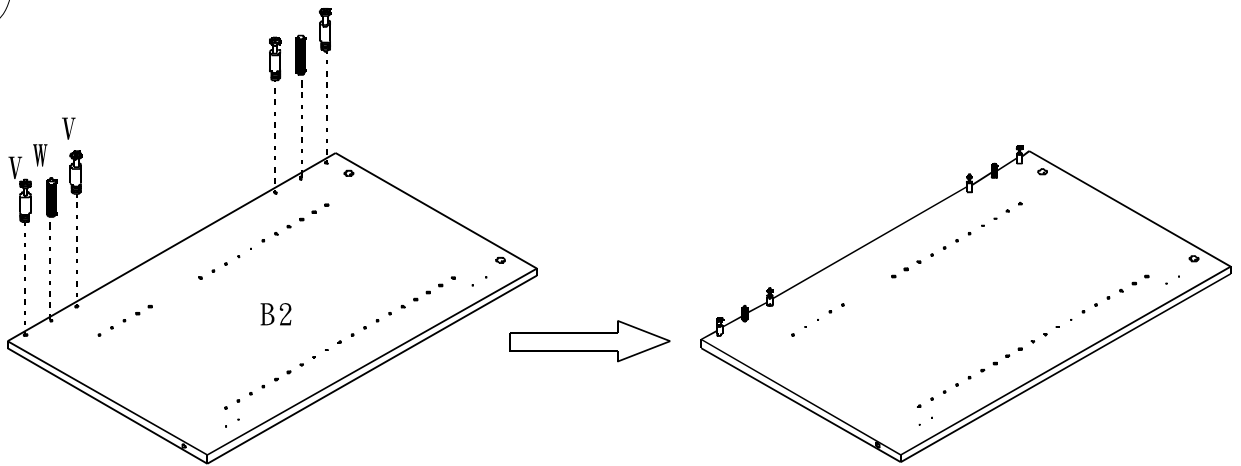

3

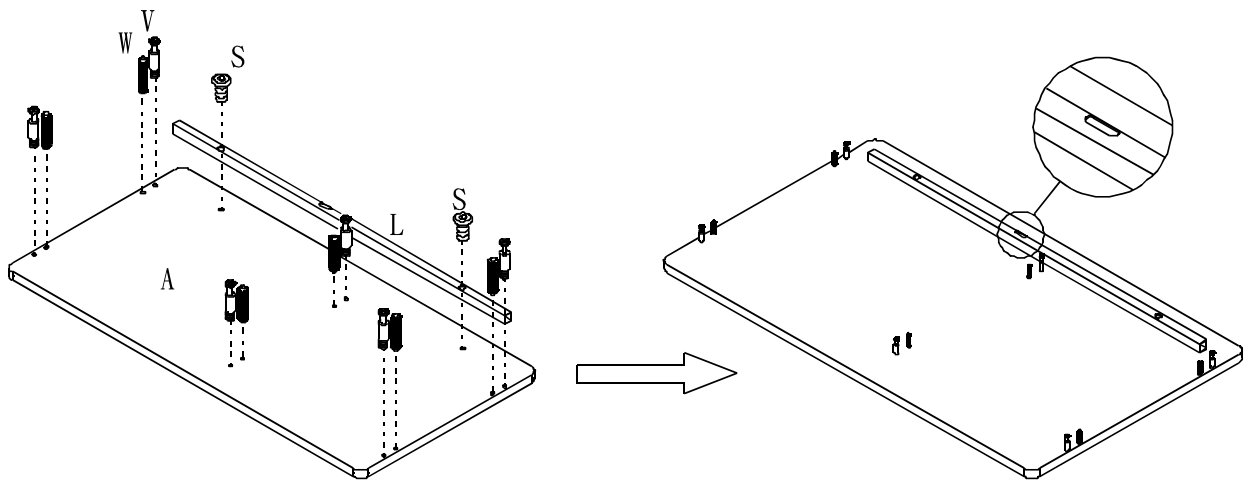

3

4

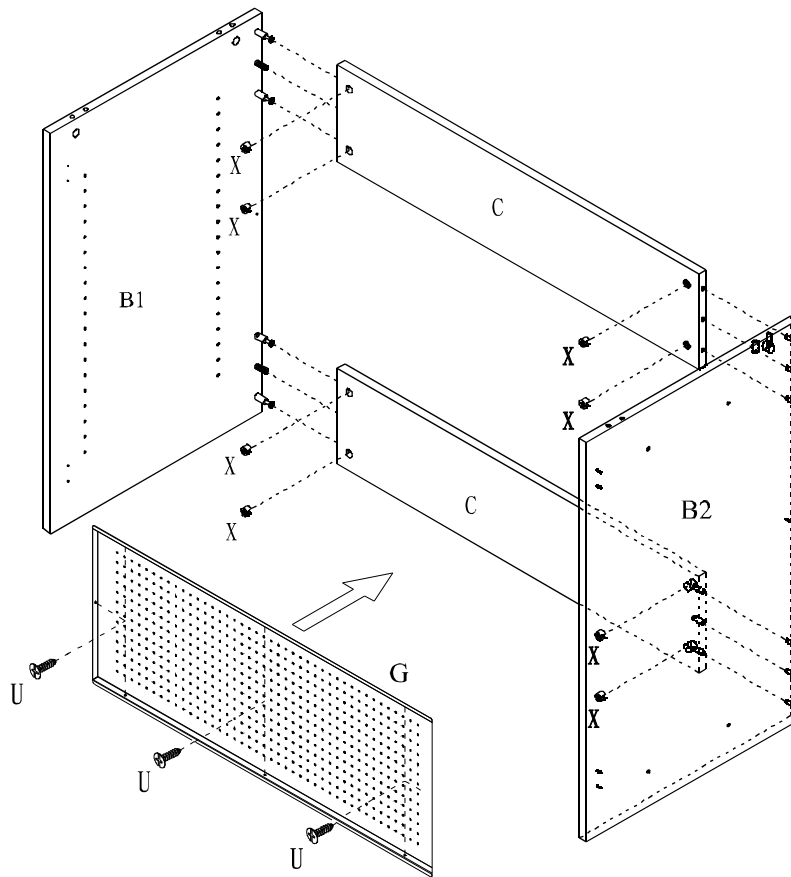

5

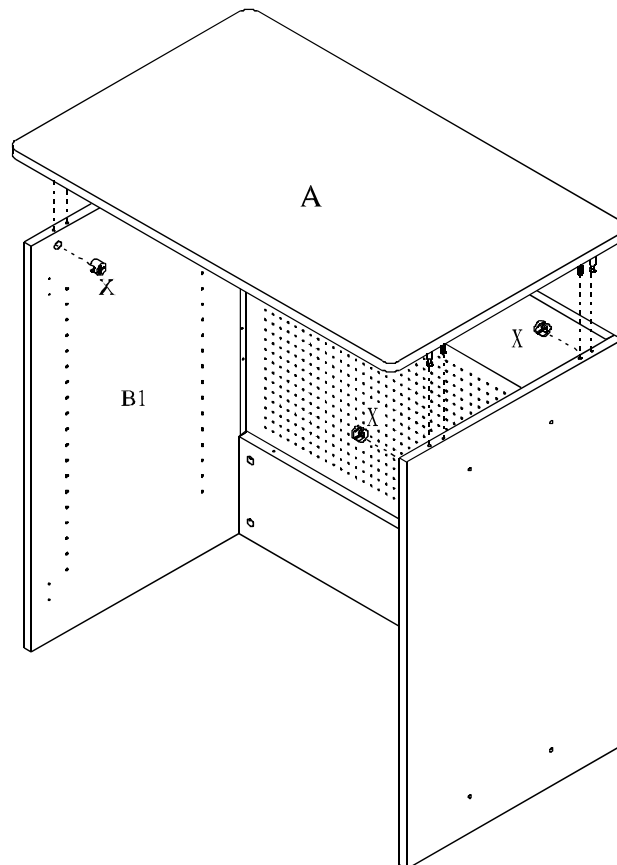

4

6

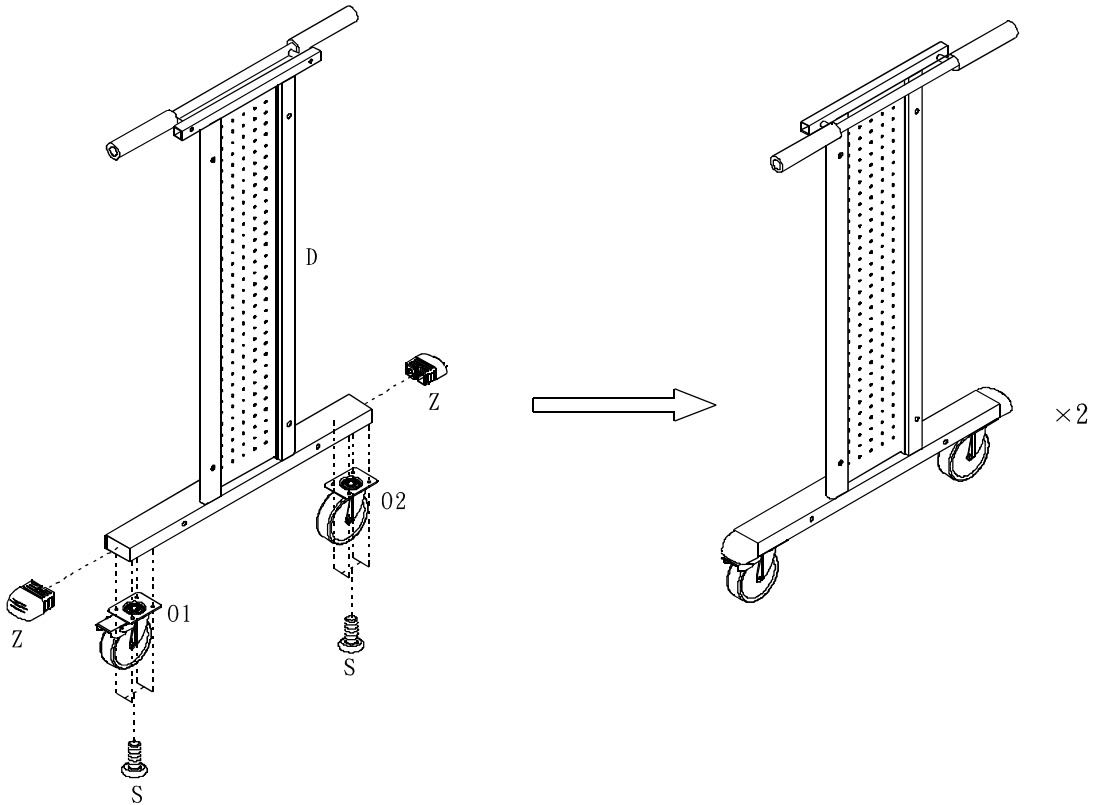

7

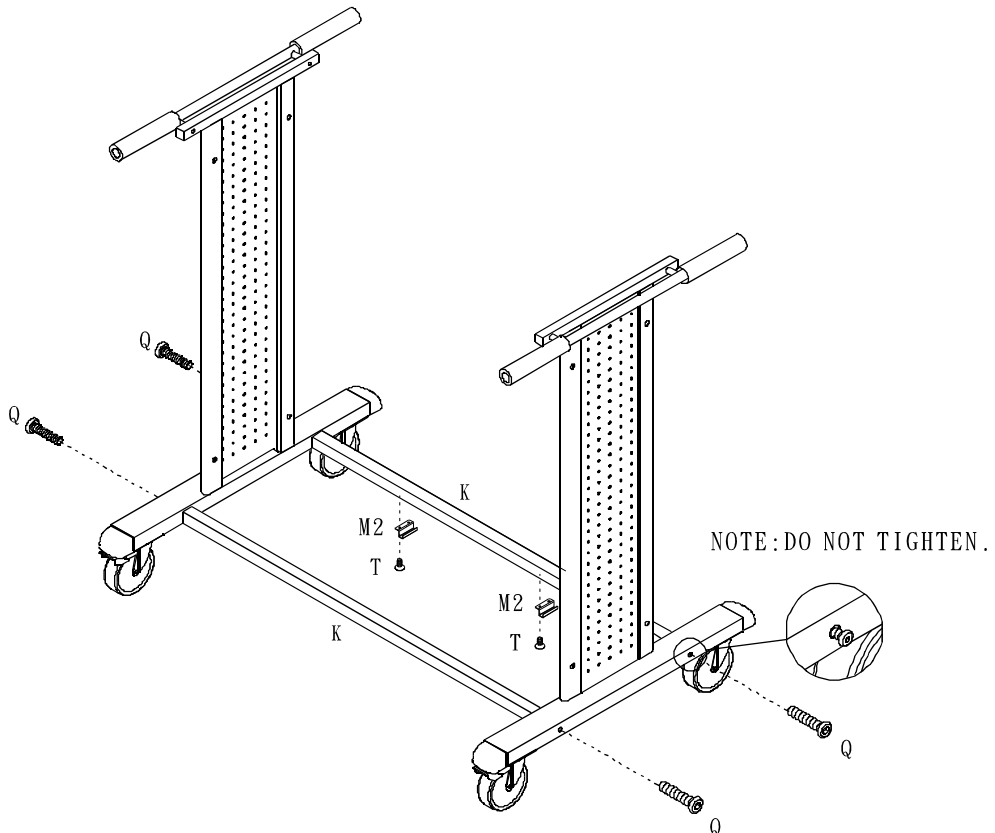

8

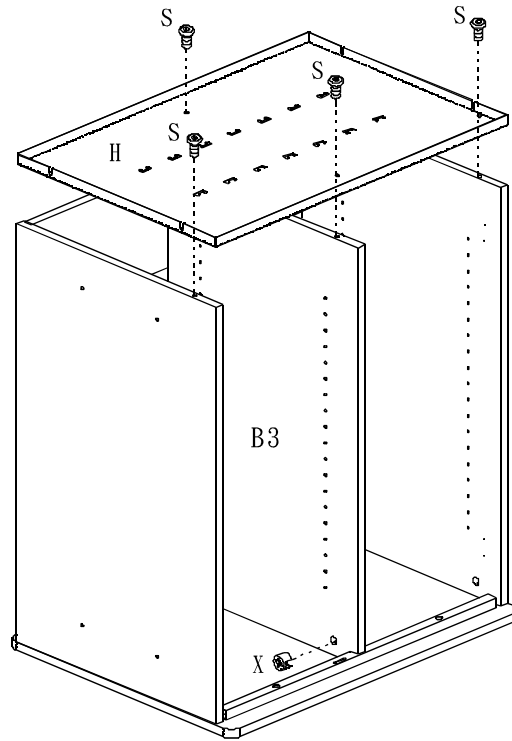

9

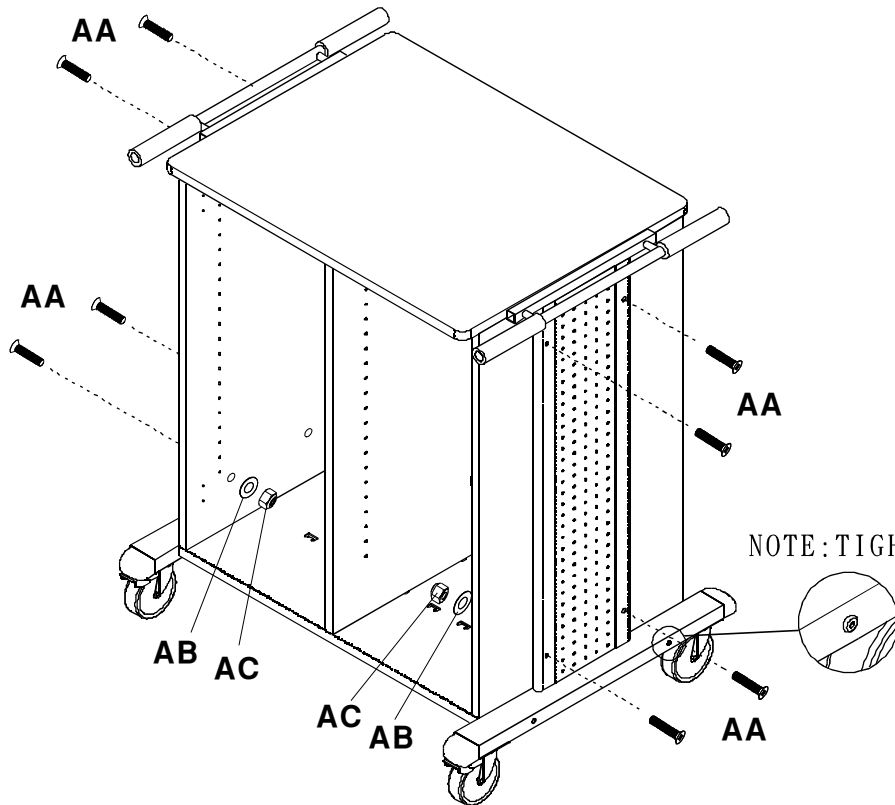

10

NOTE: DO NOT TIGHTEN.

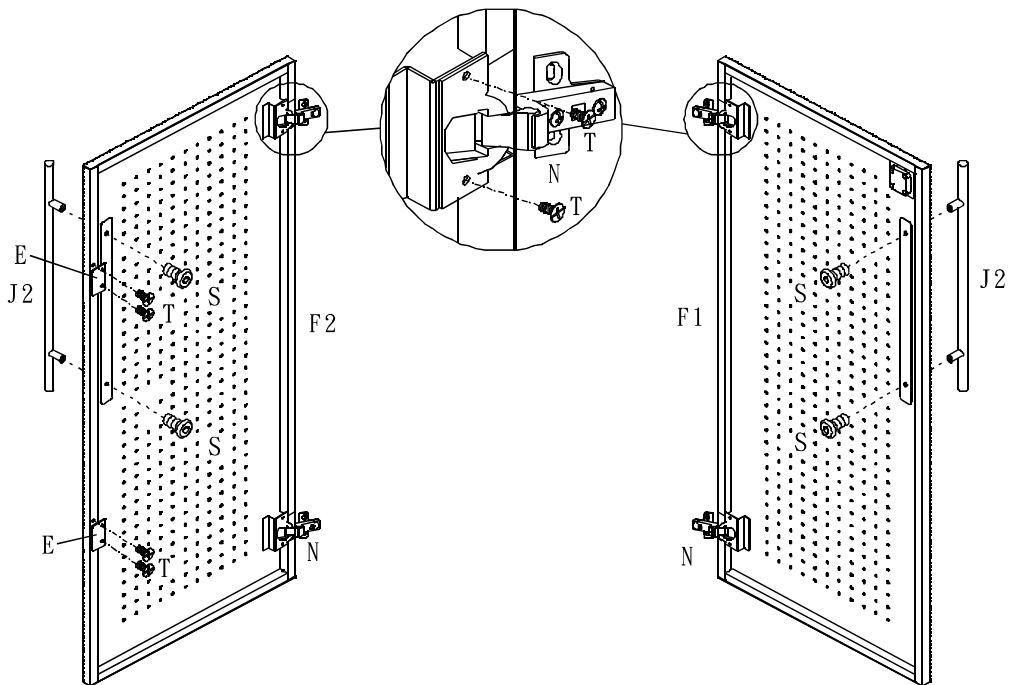

11

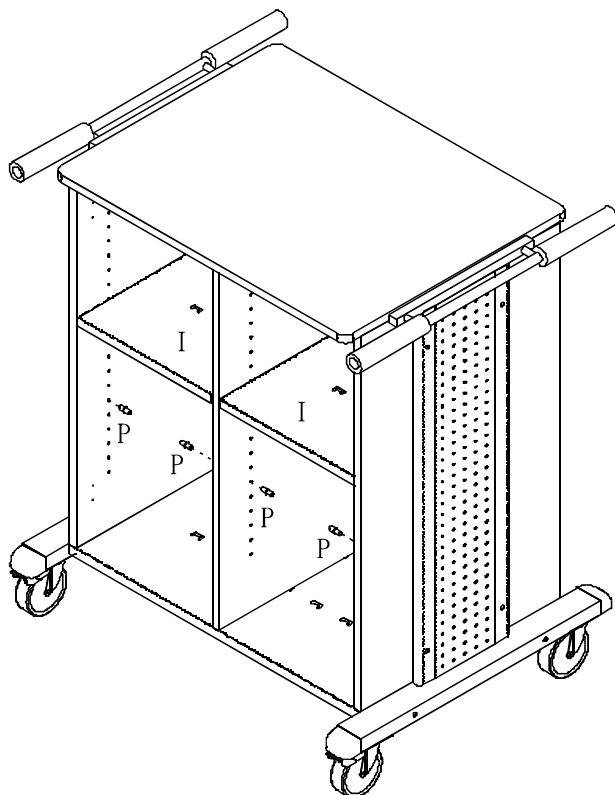

12

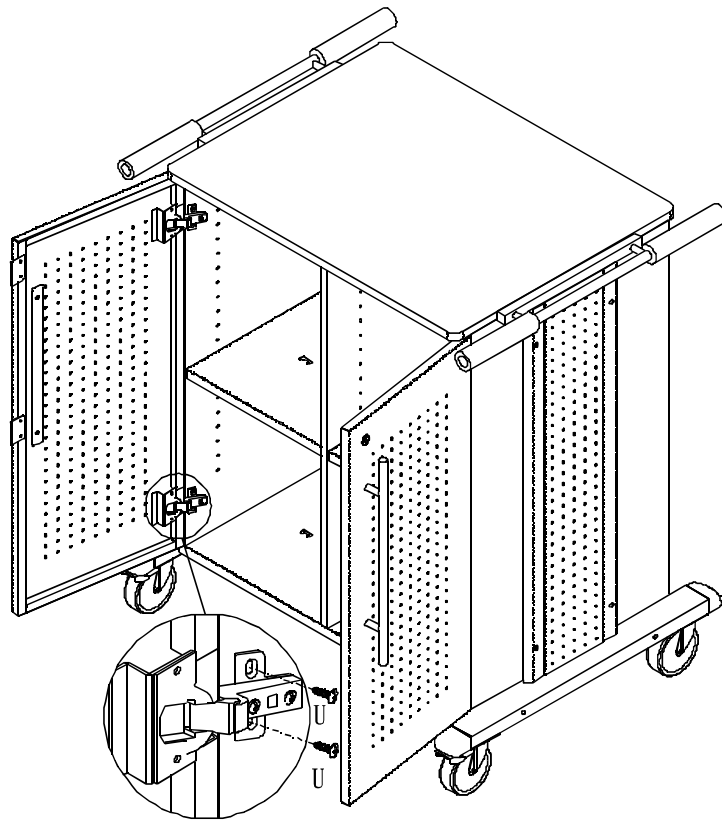

NOTE: TIGHTEN SCREWS.

13

