

Table of Contents

Page

Basic Installation Instructions

Basic Table..... 2
Basic Table Trim Panels..... 3

ASSEMBLY INSTRUCTIONS for BASIC TABLE

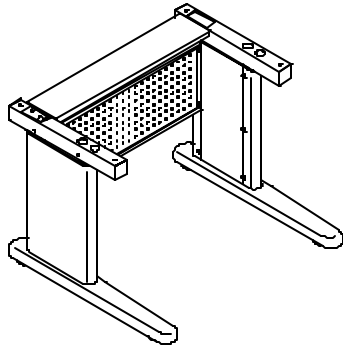

Hardware

- A. M6 x 8 Screw (8)
- B. Crank Handle (1)
- C. Particle Board Screw (6)
(included with top)

Components:

- D. Right Leg Assembly (1)
- E. Left Leg Assembly (1)
- F. Modesty Panel (1)
- G. Cross Brace Support (1)
- H. Hex Shaft (1)

NOTE: Assemble the unit on its side.

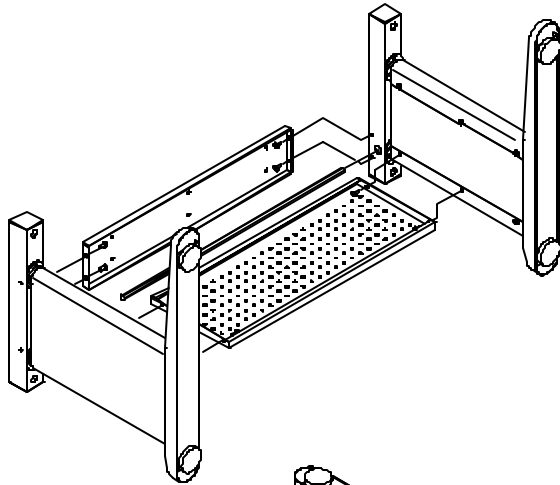

1. Loosely attach the Cross Brace Support (G) to the Left and Right Leg Assemblies (D & E) using 4 Screws (A).
2. Insert the Hex Shaft (H) into the hex socket near the top of each Leg Assembly. DO NOT attempt to rotate the shaft till it has been inserted into both end assemblies.
3. Loosely attach the Modesty Panel (F) to the Leg Assemblies using 4 Screws (A)
4. Tighten all screws.

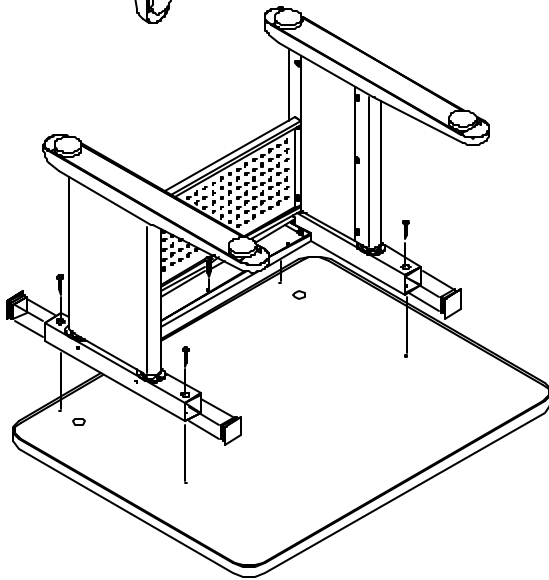

NOTE: If you have ordered the OPTIONAL Trim Panels, install them NOW per the instructions that are included with that product.

5. Place the Worksurface face down onto a solid protected surface.
6. Invert the assembled Base and align the holes in the top mounting tubes with the holes in the underside of the worksurface. Removing the end caps from the Leg Assembly tubes will allow you to better see the alignment of the holes.
7. Attach the Base to the worksurface with 2 Screws (C) per tube. Replace the tube end caps.
8. Secure the Cross Brace Support (F) to the top with 2 Screws (C) in the center holes of the Support.
9. Turn the table over onto its legs and adjust the levelers as required.
10. Insert Crank Handle (B) into either worksurface hole to adjust table height.

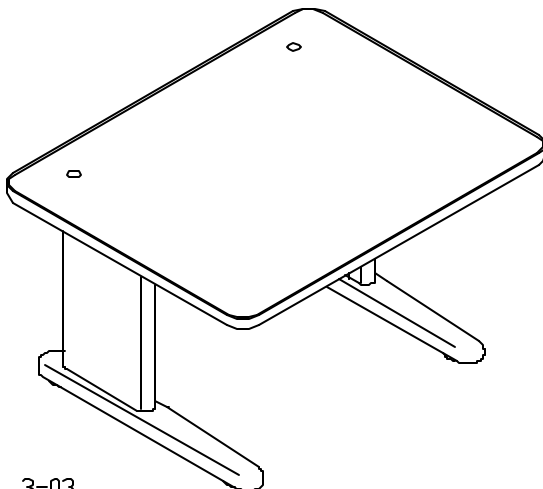

ASSEMBLY INSTRUCTIONS for BASIC TABLE TRIM PANELS #200LC

Components:

Side Trim Panel (2)
Rubber Bumper (4)

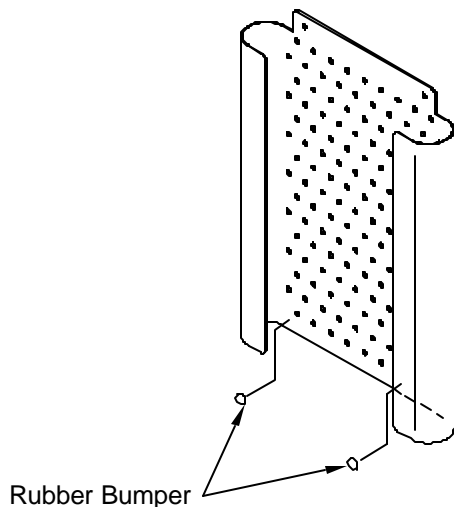

NOTE: These Trim Panels may be installed with the table in any position and may be installed after worksurface has been attached.

1. Apply two Rubber Bumpers to the inside/bottom of each side panel. Clean an area near the bottom, on the flat surface of the panel. Press the bumpers in place.
2. Remove the screws in the side of the upper top mounting tubes (2 per side). Save these screws to attach the trim panels.
3. Align the holes at the top of the Trim Panel with the side holes of the upper top mounting tubes.
4. Attach the Trim Panels with the screws.

