

ASSEMBLY INSTRUCTIONS

for 'E' Series VariTask

NOTE: Install base so Power Plug is easily accessible

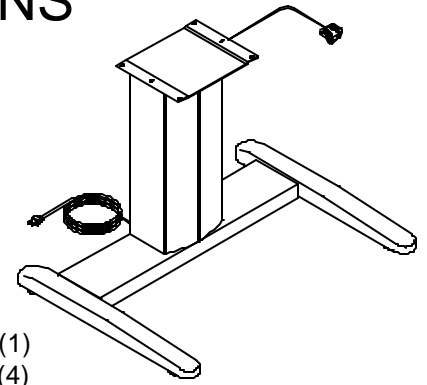
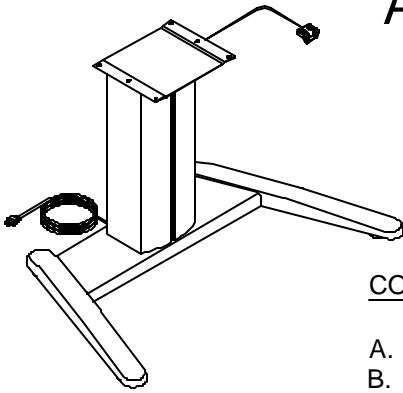

COMPONENT PARTS:

- A. Column (1)
- B. Base Legs (1)
- C. Top Plate (1)

HARDWARE BAG PARTS:

- D. Switch Assembly (1)
 - E. Glide (4)
 - F. 1/4-20 x 1 3/4 Hex Screw (4)
 - G. Lock Washer (8)
 - H. 1/4-28 X 1/2 Hex Screw (4)
 - *J. 1/8" Cable Clamp (1)
 - *K. 3/16" Cable Clamp (1)
 - *L. 3/8" Cable Clamp (1)
 - *M. #10 x 3/4 Pan Head Screw (9)
 - *N. #8 x 3/4 Flat Head Screw (2)
- This hardware is included for the proper attachment of a Work Surface and the control box.

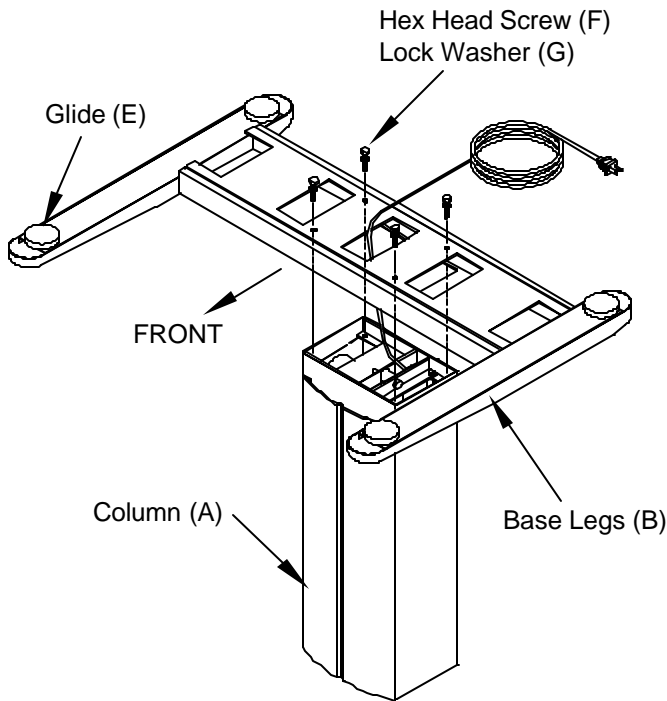

MOUNTING BASE LEGS to COLUMN

1. Place Column Assembly (A) on end with Power Cord up.
2. Turn the Base Legs (B) upside-down and position the front of the base legs toward the front of the column.
3. Carefully feed Power Cord through center opening in the base and through center opening in bottom.
4. Position large opening in base over column and lower into place. NOTE: Do Not pinch Power Cord.
5. Fasten base with four 1/4-20 x 1 3/4 Hex Head Screw (F) and four 1/4 Lock Washer (G).
6. Install Glides (E) into Base Legs.

MOUNTING TOP PLATE to COLUMN

7. Turn Column/Base upright and install Top Plate (C).
8. Place Top Plate (C) in a front biased position. Secure with four 1/4-28 x 1/2 Screws (H) and four 1/4 Lock Washers (G).
9. Connect Switch Assembly (D) to Wiring Coupler extending from the Column side.

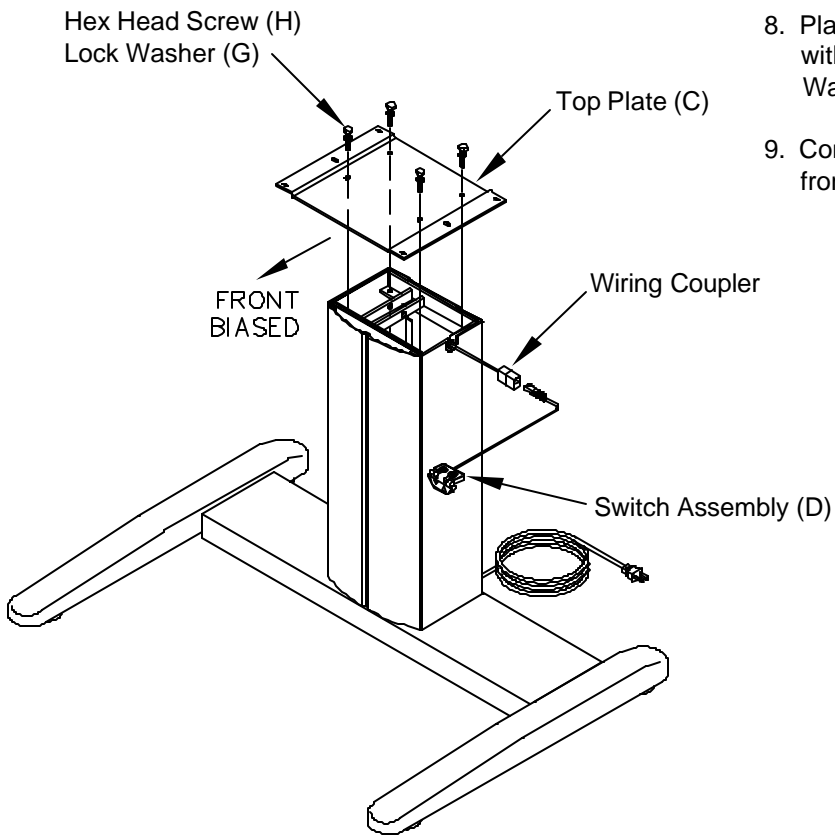

NOTE:

For Base Assemblies equipped with optional Casters, install Locking Casters in the front holes of the base.

