

ASSEMBLY INSTRUCTIONS
COMFORT SERIES - BIG & TALL
EXECUTIVE CHAIR (FABRIC)
MODEL NO. 1801AG



IMPORTANT!

Review ALL instructions before beginning assembly. These instructions are provided to avoid problems that may occur from improper assembly or installation. Mayline and/or its distributor are not responsible for failure resulting from improper assembly or installation of this product. Moreover, all warranties are void for failure to follow these assembly instructions.







Mayline Company, LLC
619 N. Commerce, P.O. Box 728
Sheboygan, WI 53082-0728
Toll Free: 1-800-822-8037
FAX: 920-457-7388
On Line: www.mayline.com



PARTS LIST 1801AG

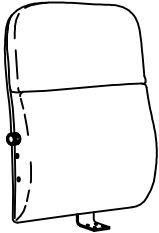

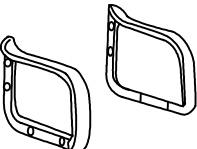
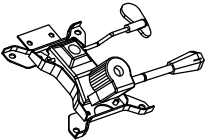

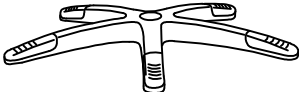
When ordering components, specific color and/or size information may be required.
Contact a Mayline Customer Service Representative. 1-800-822-8037

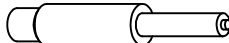
* Individual Items, Order by part number.

** Denotes Color Code

Reference Letter A*		Quantity 1
Part Number CM500** Back		
Reference Letter B*		Quantity 1
Part Number CM501** Seat		
Reference Letter C*		Quantity 1
Part Number CM327** Arms (pair)		
Reference Letter D*		Quantity 1
Part Number CM331 Mechanism		
Reference Letter E*		Quantity 5
Part Number CM336 Caster (5 pack)		
Reference Letter F*		Quantity 1
Part Number CM340 Base		

Reference Letter G*		Quantity 1
Part Number CM481 Cylinder		
Reference Letter H*		Quantity 1
Part Number CM350 Cylinder Cover		

Part Number CM360 * Hardware Pack			
Reference Letter J		Quantity 4	Spare 1
Screw M8 x 32mm			
Reference Letter K		Quantity 8	Spare 1
Screw M8 x 22mm			
Reference Letter L		Quantity 4	Spare 1
Screw M8 x 35mm			
Reference Letter M		Quantity 8	Spare 1
Arm Caps			
Reference Letter N		Quantity 1	
Allen Wrench			

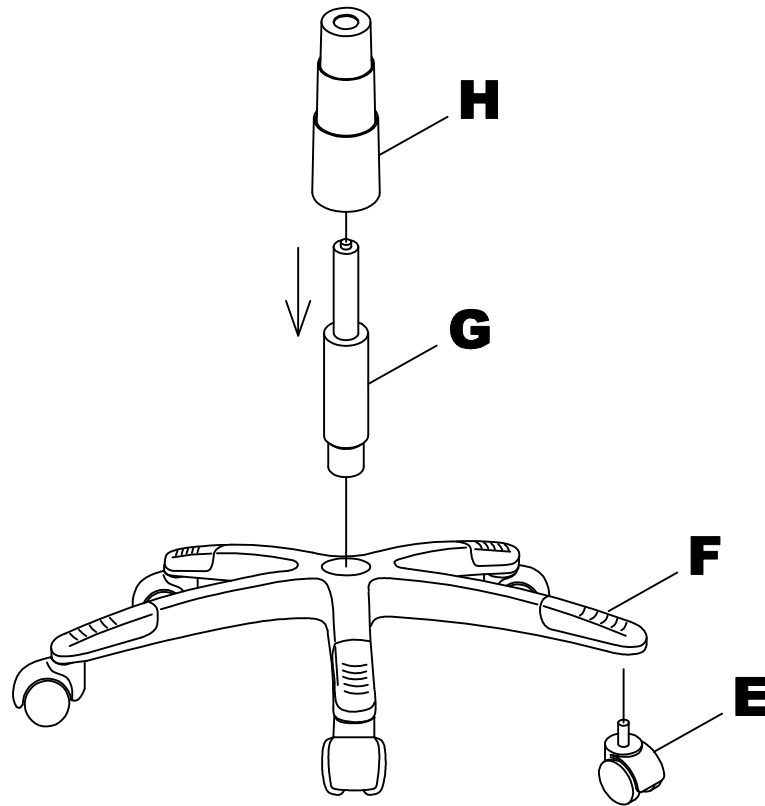

1. Place Base (F) upside down and push Casters (E) firmly into base. 5 places.
2. Turn Base right side up and insert Cylinder (G) into center hole of Base.
3. Place Cylinder Cover (H) over Cylinder.

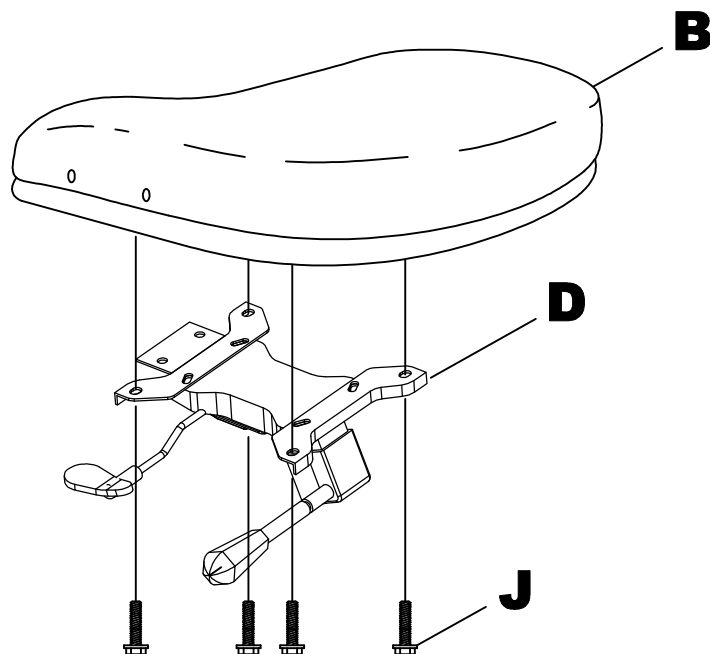

4. Assemble Mechanism (D) onto Seat (B) using Screws (J) 4 places.

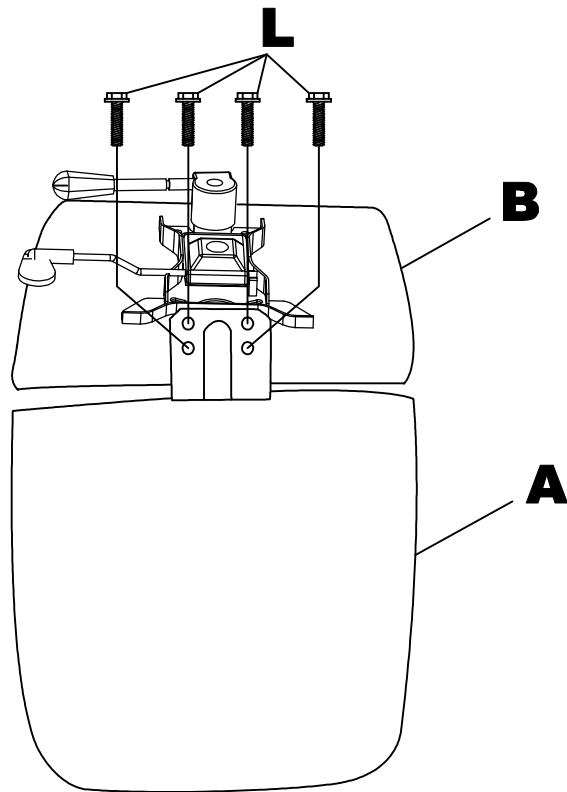

5. Assemble Back (A) onto Seat (B) using Screws (L) 4 places. **DO NOT TIGHTEN SCREWS** at this time. This will allow a tolerance when assembling arms.

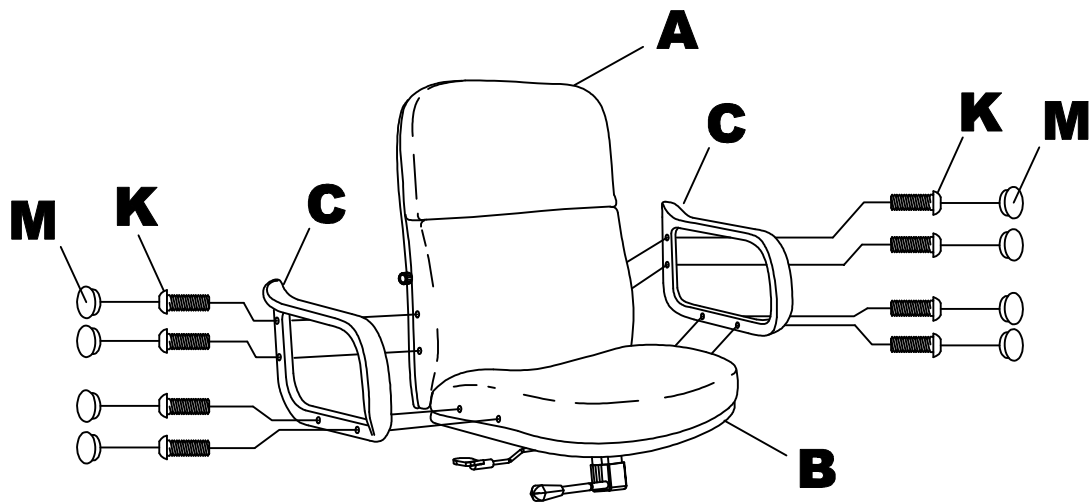

6. Assemble Arms (C) 2 places onto Back (A) & Seat (B) using Screws (K) 8 places. **DO NOT TIGHTEN SCREWS** at this time.

7. After both arms are installed tighten all Screws (K & L) 12 places.

8. Insert Arm Plugs (M) into Arms (C) 8 places.

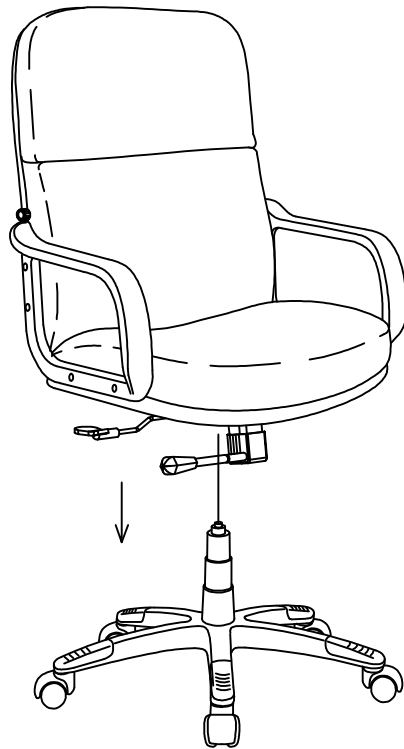

9. Carefully place chair assembly onto base assembly.

NOTE:

Periodically (Every 90 days) make sure screws are fully tightened.

OPERATING INSTRUCTIONS FOR CENTER PIVOT MECHANISM

1. Seat Height Adjustment.

To raise the seat, pull lever upward and raise your body up slightly to allow the chair to rise to the desired height.

To lower the seat, pull lever upward and apply weight downward on the seat.

Seat Upright Lock.

To lock chair in upright position, lean forward and push knob toward chair.

To unlock chair in upright position, lean forward and pull away from chair.

2. Tilt Tension Control Knob.

Turn knob clockwise to increase tilt tension.

Turn knob counter-clockwise to decrease tilt tension.

