

ASSEMBLY INSTRUCTIONS

4 COLUMN RECT. XR BASE

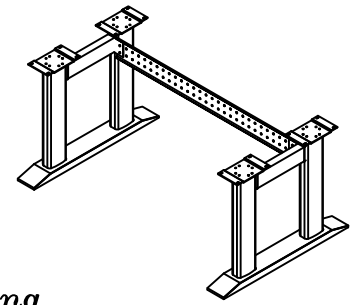

NOTE: *Column Assemblies are heavy. Use care to avoid dropping column or allowing column assembly to fall during assembly or damage to internal glide system may occur!*

NOTE: *Please count and inspect all pieces before disposing of any carton or packing materials.*

COMPONENTS: When ordering components, specific size information may be required. Contact a Mayline Customer Service Representative. 1-800-822-8037

REF. #	QTY.	DESCRIPTION	PART No.
1	4	LIFT ACTUATOR	Z460
2	2	XR FOOT, 30"	A8174
3	1	ACT. SUPPORT, LEFT	A8176
4	1	ACT. SUPPORT, RIGHT	A8177
5	1	CHANNEL CROSS	520CC**03 (50"), 520CC**04 (44") **Denotes Color
6	4	TOP PLATE	B6969
7	2	CONTROL BOX, 2 LEG	Z537
8	2	MEMORY SWITCH	Z463
9	2	MAIN CABLE	Z467
10	4	1000mm MOTOR CABLE	Z464

HARDWARE BAG (PART No. A9209) *For individual item, order by part number

REF. #	QTY.	DESCRIPTION	PART No.	
E1	32	M6 X 16mm SCREW	X419	
E2	32	STAR WASHER	W29	
E3	4	GLIDE	Q607	
E4	6	#10 X 3/4 SCREW	X11	
E5	6	#10 x 1" SCREW	X12	
E6	4	#6 X 5/8 SCREW	X10	
E7	4	1/4-20 X 1/2 SCREW	X352	
E8	4	1/4-20 KEPS NUT	T126	
E9	6	CABLE CLAMP	F191	
E10	4	#8 x 1.75" SCREW	X533	

OPTIONAL HARDWARE

REF. #	QTY.	DESCRIPTION	PART No.
11	1-2	Anti-Collision Dongle	Z498



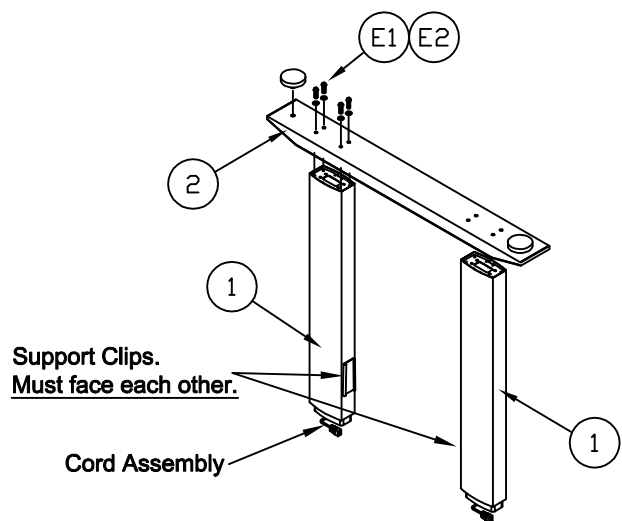

1. Place two Lift Actuators Columns (1) upside down with the cord toward the floor with support clips facing inward. CAUTION: Make sure strain relief is snapped into place on actuator.... Do not pinch Cord Assembly.

2. Position the XR Foot (2) over Columns. Note: Direction does not matter.

3. Attach the XR Foot (2) to the two Actuator Columns (1) with four M6 x 16 mm Screws (E1) and Star Washers (E2). Attached two Glides (E3) to bottom of foot. Repeat for other pair of Lift Actuator Columns and Foot.

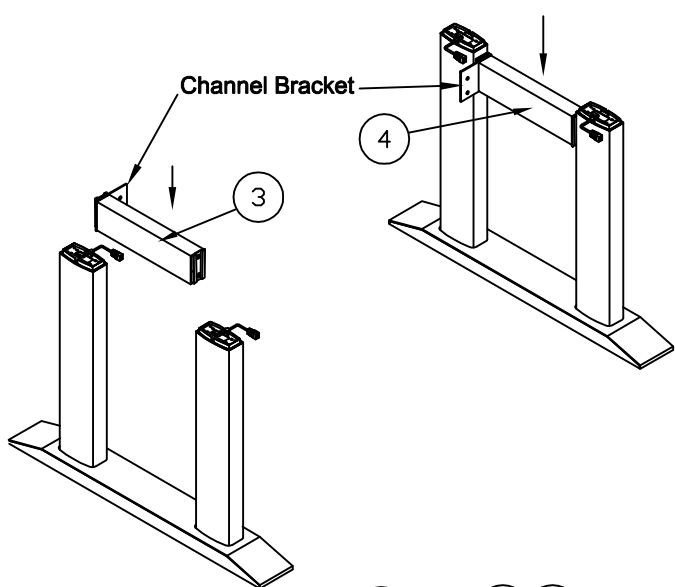

4. Place the assembled columns upright and attach the Left (3) and Right (4) Actuator Supports between the Columns. Position the Supports so the Channel Brackets face toward each other. Slide the Support brackets onto the tapered support clip on each Actuator Column. Gently tap the Act. Supports in place with a Rubber Mallet to assure a tight fit.

5. In the event that you must reposition the Actuator Cord. Gently remove the cord and strain relief from the notch in the top of the Actuator Column (1). Position the cords so that they are toward the center of the assembled base. Insert the strain relief into the appropriate Actuator notch.

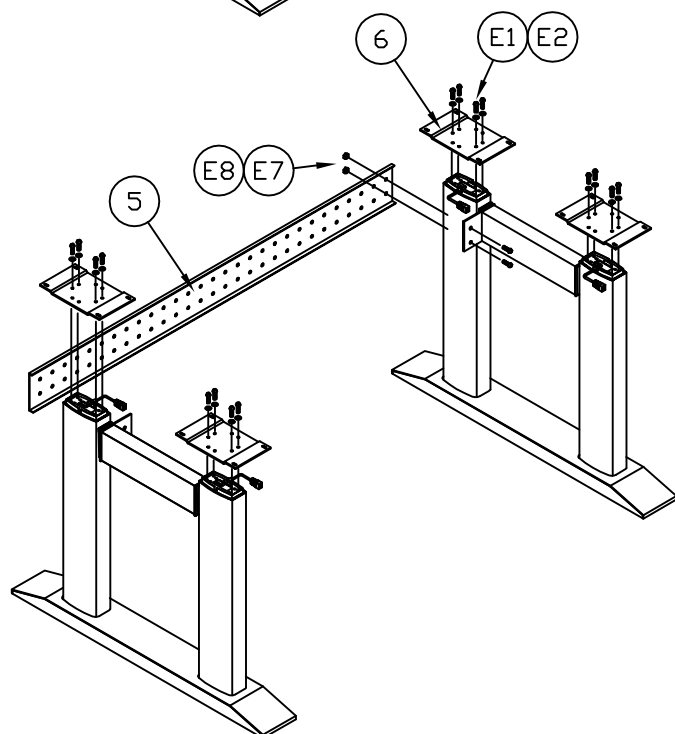

6. Attach Top Plate (6) to each Actuator Column with four M6 x 16 mm Screws (E1) and Star Washers (E2).

7. Attach the Cross Channel (5) to the Actuator Support Channel Brackets with four 1/4-20 X 1/2 Screws (E7) and 1/4-20 KEPS Nuts (E8).

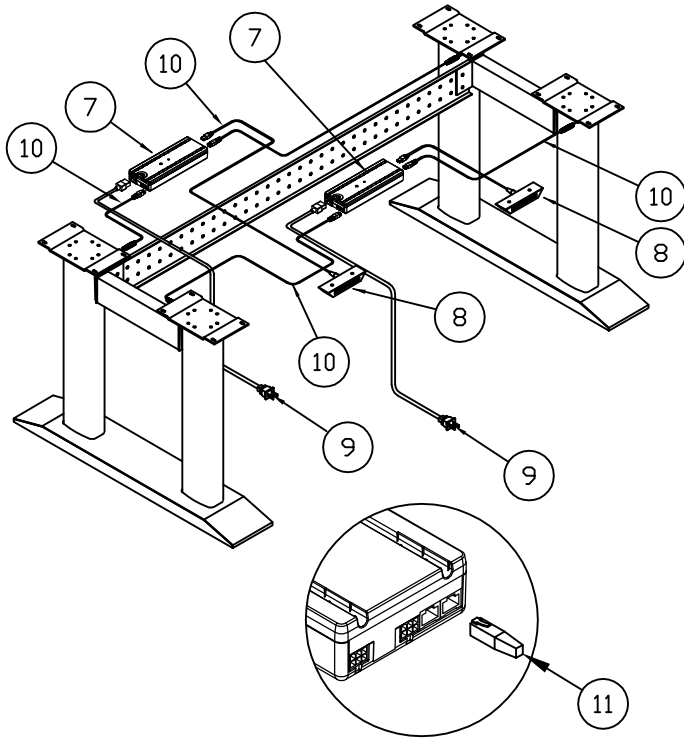

8. Attach Memory Switch (8), Main Cable (9), and the 1000mm Motor Cables (10) to the Control Boxes (7).

9. Attach Anti Collision Dongle Option (when ordered). To install the Anti Collision Dongle (11), simply plug the dongle into one of the two control (switch) ports on the Control Box (7). The function is only active when the dongle is mounted - if you remove the dongle you disable the function.

Note: Situations where anti-collision does not work.

- 1) If the collision happens during the initialization stage.
- 2) If the collision happens within the first 1000 msec or after the control button has been released.
- 3) If the collision time span is too long, i.e. if the collision is with a soft object.

NOTE:

- a) #10 x 3/4" Screws (E4) are provided for Cable Clamp installation only.
- b) #10 x 1" Screws (E5) are provided for Work Surface attachment only.
- c) #8 x 1 3/4" Screws (E10) are provided for Control Box installation only.

7. PRIOR TO ATTACHING A WORKSURFACE. Place the REAR SURFACE Memory Switch cable over the top of the Cross Channel.

8. Align the holes in the Top with the holes in the Top Plates (6) and secure in place with eight #10 x 1" Screws (E5).

9. Choose a desired location for the Control Boxes (7) and attach with two #8 x 1 3/4" Screws (E10). Connect the motor cables to the columns.

10. Place the Memory Switch (8) in a comfortable and accessible location on the underside of the Top and attach it with two #6 x 5/8 Screws (E6).

11. Route the Actuator Column cables and the Switch cable away from moving components and secure them in place with Cable Clamps (E9) and Screws (E4).

ATTENTION:

MAYLINE includes screws for the installation of a Work Surface with a minimal thickness of 1 inch (25.4mm).

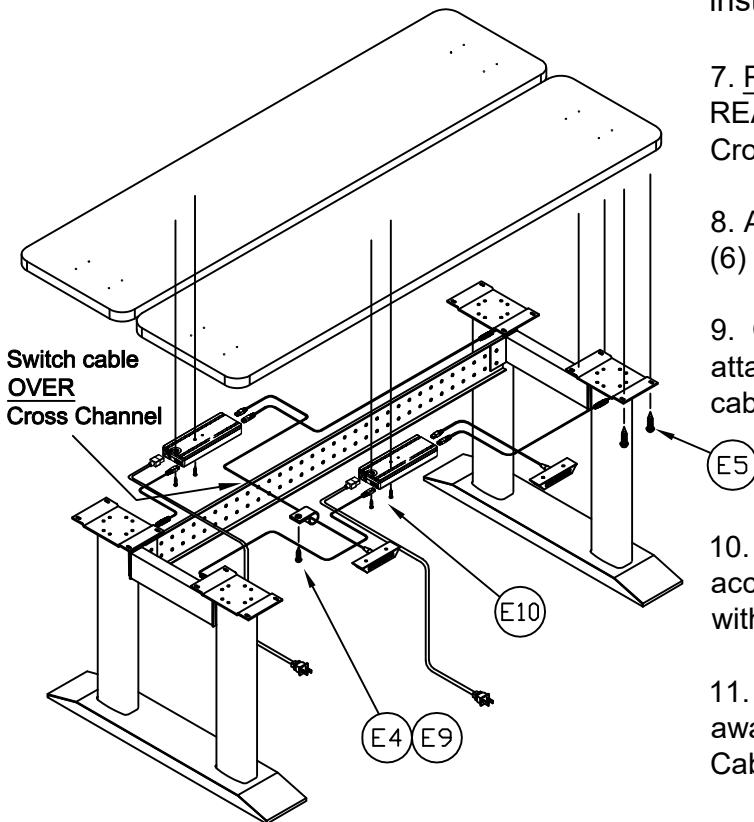





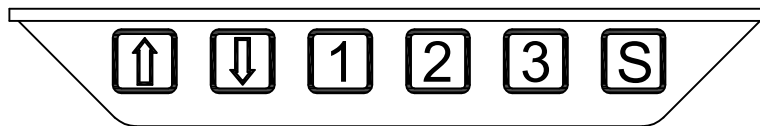
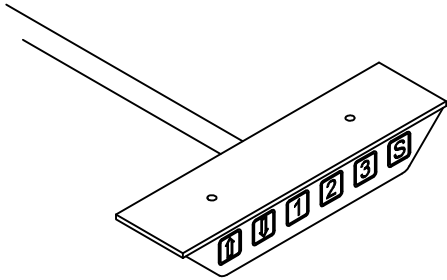







NOTE: When table has been moved into final location, level table to ensure proper performance.

INSTRUCTIONS for DESK SWITCH w/ PROGRAMMABLE MEMORY



NOTE: Prior to **INITIALIZATION** of the system, the **Base** must be level. Acheive this by adjusting the leg glides.

1. Initialize system by pressing down  and holding for 5 to 10 seconds after table bottoms out.
2. Push 'UP'  to desired height.
3. To save this position in Memory:
 - A.) Press  (Set)
 - B.) Press (do not hold) button  ,  , or Position is now saved under the number chosen.
4. To change to different height, press  or  .
This position may be saved by repeating Step 3 and using one of the other buttons or using the same button to change the previous setting. Up to 3 positions may be stored.
5. To go to new height position, press  or  , or press stored height under  ,  , or  . Unit will automatically stop at the stored position.