

Assembly Instructions

COMMUNICATION STATION FREESTANDING WORKTABLES





NOTE: Please count and inspect all pieces before disposing of any carton or packing materials.

COMPONENTS

When ordering components, specific color and/or size information may be required. Contact a Mayline Customer Service Representative. 1-800-822-8037

REF. #	QTY.	DESCRIPTION	PART No.	
1	1	Top	CALL~~**	** Denotes Color Code
2	2	Universal Leg Assembly	CALL~~**	~~Denotes Size
3	1	Modesty Panel	CALL~~**	

HARDWARE BAG (PART No. 610008) *for individual item, order that part number

REF. #	QTY.	DESCRIPTION	PART No.	
E1	8	1/4-20 x 1/2" Pan Head Screw	7005*	 
E2	4	#12 x 3/4 Hex Head Screw	710232*	 
E3	4	Floor Glide	600128*	
E4	2	Cable Clamps	9026	

Tools required for assembly:

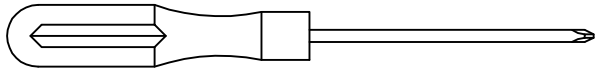

Phillips Screwdriver

Note: A magnetic or power driver may be used to assist in assembly.

Part Identification:

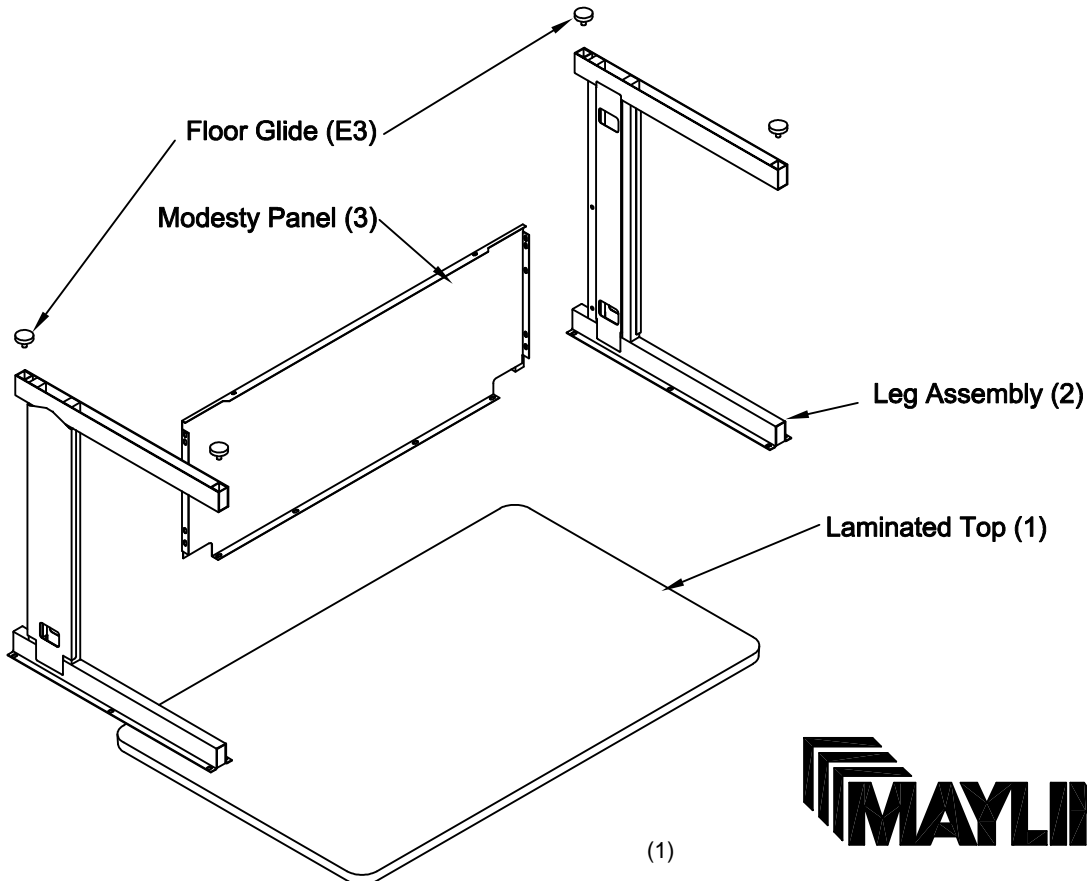

(1)

Assembly:

1. Begin assembly by placing the Laminated Top (1) upside down on a clean flat worksurface.
2. Locate and position the Universal Leg Assemblies (2). Secure by inserting and starting Screws (E1) through the Leg assembly into the inserts installed in the Top. NOTE: Do Not tighten at this time.

NOTE: Universal Leg Assemblies (2) can be changed from right hand to left hand by removing the metal inserts and installing them in the reverse position. See Fig. #1 To remove insert, slide the insert to the top of the leg, rotate the bottom out, removing the tab from the cut out in the leg rail, then slide the top of the insert from the top leg rail. Install in reverse order.

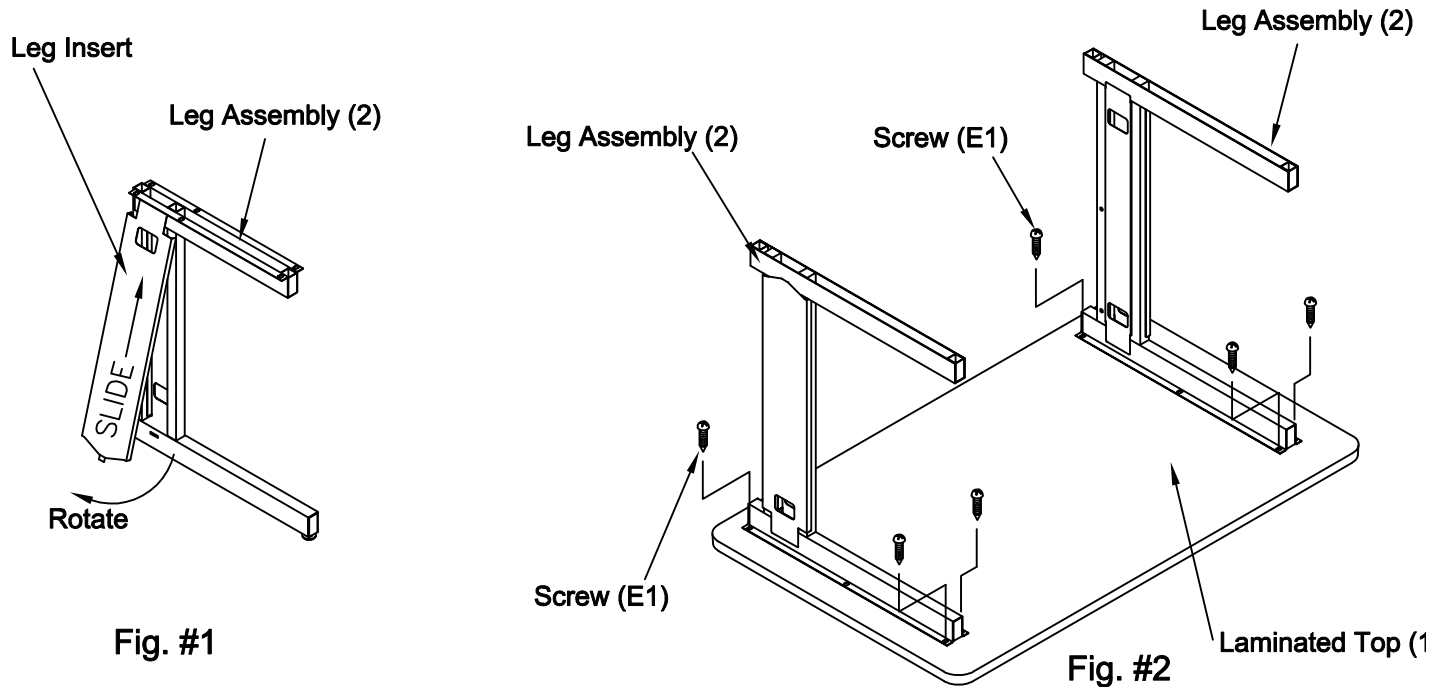

3. Attach the Modesty Panel (3) to the Universal Leg Assembly (2) with four Screws (E1). Secure the Modesty Panel (3) to the Top (1) Using four Screws (E2). Tighten these screws first, then tighten all remaining screws.
4. Install the Floor Glides (E3) in the Leg Frames by inserting the threaded stud into the plastic sockets and rotating clockwise.

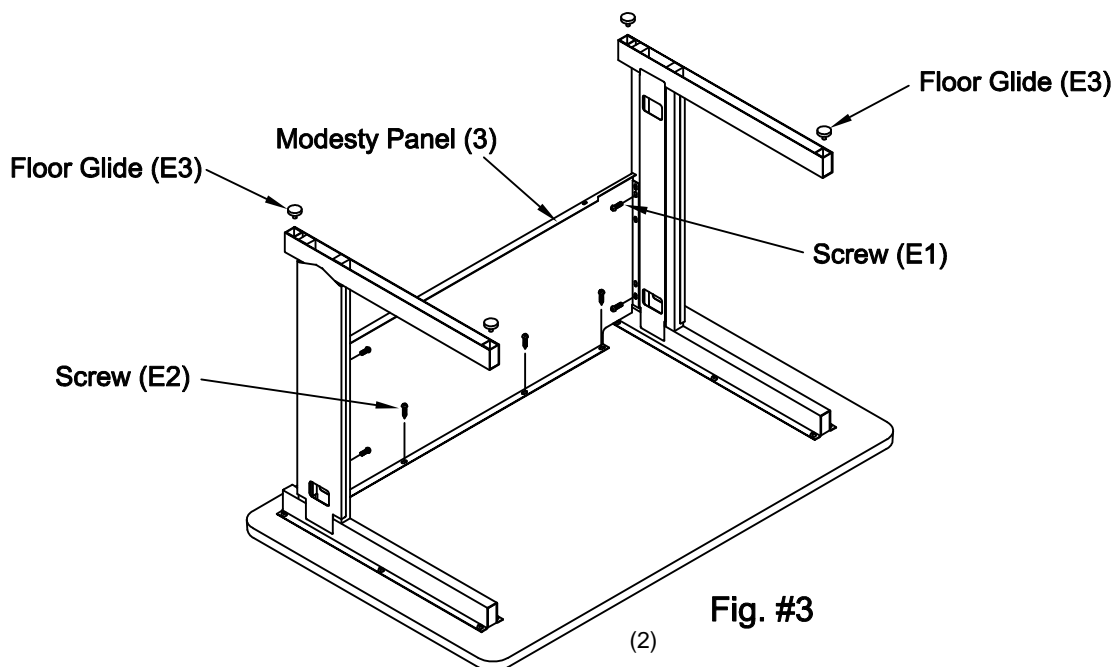

6. Cable Clamps (E4) are provided to assist with the organization of cables. To install the Cable Clamp, determine the location and thoroughly clean the surface. Remove the paper backing from the Clamp and firmly press the Clamp into position. To release the Clamp, press the release tab to allow the installation of cables. To close, push on Clamp until it snaps shut.

