

ASSEMBLY INSTRUCTIONS





Stationary Shelf

NOTE: Please count and inspect all pieces before disposing of any carton or packing materials.

COMPONENTS: When ordering components, specific color and/or size information may be required.
Contact a Mayline Customer Service Representative. 1-800-822-8037

<u>REF. #</u>	<u>QTY.</u>	<u>DESCRIPTION</u>	<u>PART No.</u>	
1	1	STATIONARY SHELF	CALL~~**	** Denotes Color Code ~~Denotes Size

HARDWARE BAG (PART No. A6481) *for individual item, order that part number

<u>REF. #</u>	<u>QTY.</u>	<u>DESCRIPTION</u>	<u>PART No.</u>	
E1	4	SHELF BRACKET	B4649**	
E2	8	#8-32 X 38 SCREW	X221*	
E3	8	#10-32 X 1/2 SCREW	X375*	
E4	8	#8-32 KEPS NUT	T107*	
E5	8	#10-32 CAGE NUT	T118*	

FOUR RAILS ARE REQUIRED TO MOUNT SHELF INTO CABINET

NOTE:

For best internal cabinet access to glides – level cabinet prior to positioning Rack Mount Rails and installing shelves or equipment.

1. Attach Rails approximately 4 1/2 " inboard from outer cabinet frame.
2. Select the desired height where the shelf will be mounted in the cabinet.
3. Install Cage Nuts (E4) into selected holes, two per support.

TO INSTALL CAGE NUTS (E4):

A.) Place bottom of Cage Nut through square hole from back side of rail (see detail at right), allowing the lower portion of Cage Nut to grip the rail.

B.) Compress the upper portion of the Cage Nut with your thumb and snap Cage Nut into place.

TO REMOVE CAGE NUTS (E4):

Compress Cage Nut with pliers.

4. Attach Shelf Brackets (1) with Fasteners (E2) to Rack Mount Rails in Cabinet.

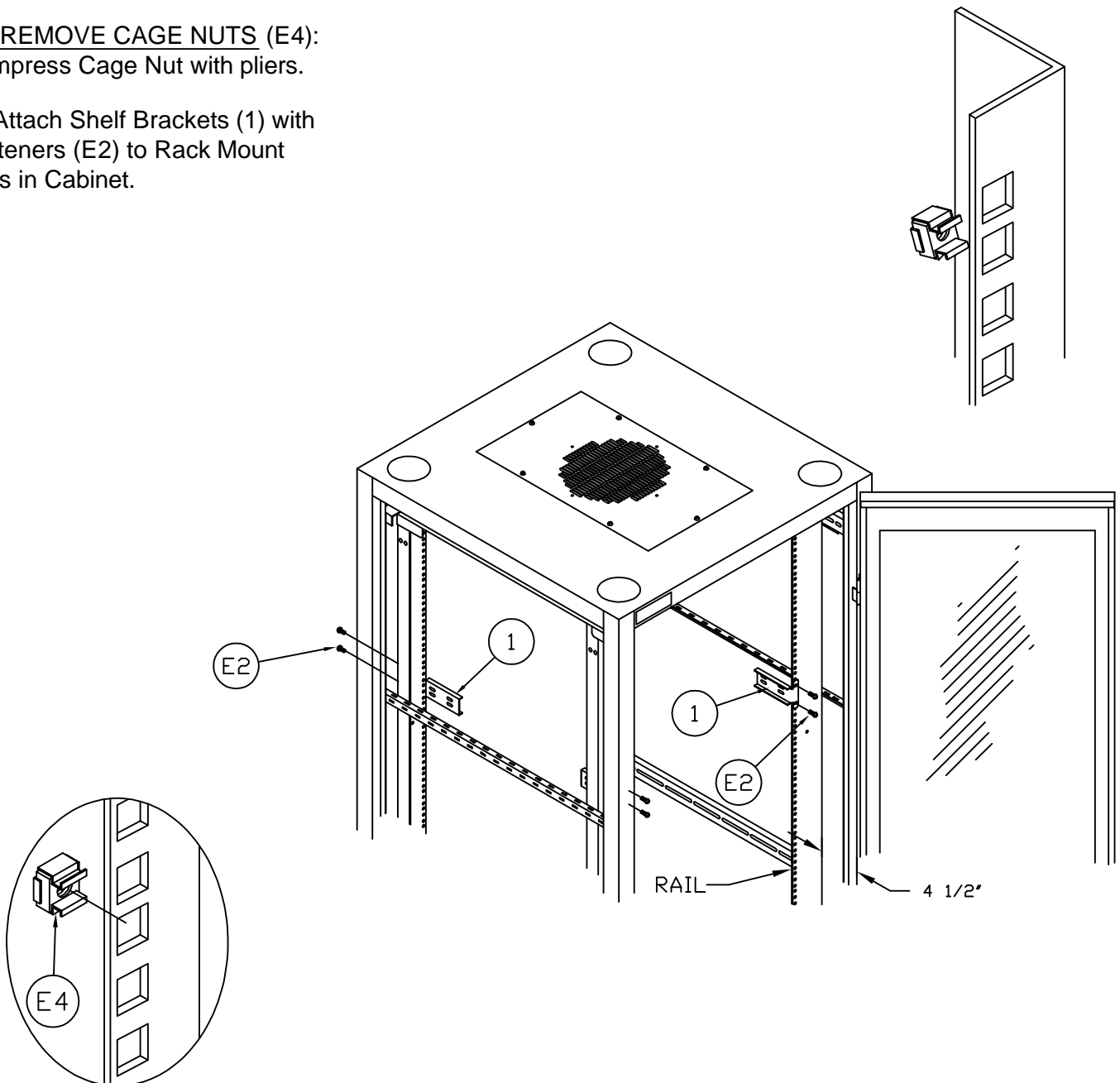

5. Position Shelf Brackets as shown.

6. Secure in place with Screws (E1) and KEPS Nuts (E3), two per support.

NOTE:
Removal of the Cabinet
Top Knockouts requires
a sharp blow with a hammer

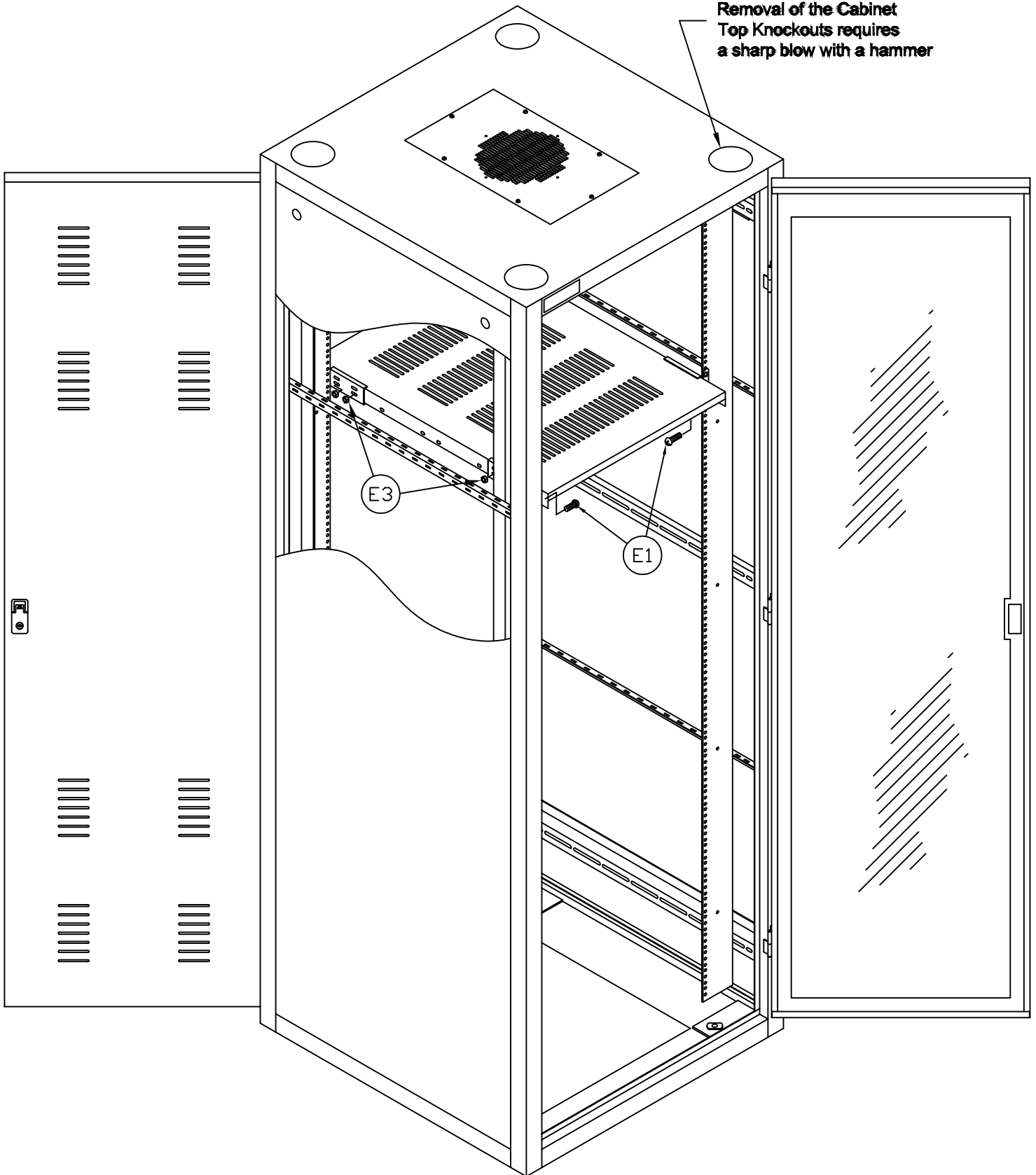

(3)