

# ASSEMBLY INSTRUCTIONS

## TechWorks™ Corner Tables







---

NOTE: Please count and inspect all pieces before disposing of any carton or packing materials.

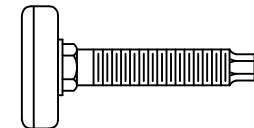
**COMPONENTS:** When ordering components, specific color and/or size information may be required. Contact a Mayline Customer Service Representative. 1-800-822-8037

<u>REF. #</u>	<u>QTY.</u>	<u>DESCRIPTION</u>	<u>PART No.</u>	** Denotes Color Code ~~Denotes Size
1	1	TOP	CALL~~**	
2	2	SPREADER	CALL~~**	
3	2	UPPER LEG ASSEMBLY	A7104**	
4	2	LOWER LEG ASSEMBLY	A7603**	
5	1	UPPER CORNER LEG	A7134**	
6	1	LOWER CORNER LEG	A7135**	

HARDWARE BAG (PART No. A7163) \*for individual item, order that part number

<u>REF. #</u>	<u>QTY.</u>	<u>DESCRIPTION</u>	<u>PART No.</u>	
E1	18	1/4-20 X 1/2 SCREW	X352*	
E2	5	GLIDE	Q588*	
E3	12	5/16-18 X 3 1/2 SCREW	X241*	
E4	8	5/16-18 X 3/4 SCREW	X410*	
E5	20	5/16-18 HEX NUT	T130*	
E6	20	LOCK WASHER	W77*	
E7	4	HOLE PLUG	F639*	

1. Select height for table using the holes in the Upper Leg (3). See Fig.1

2. Insert Screws (E3) through Upper Leg (3) and Lower Leg (4) at desired position (12x). Secure using four Lock Washers (E6) and four Hex Nuts (E5) where shown. See Fig 2. Do not tighten hardware at this time.

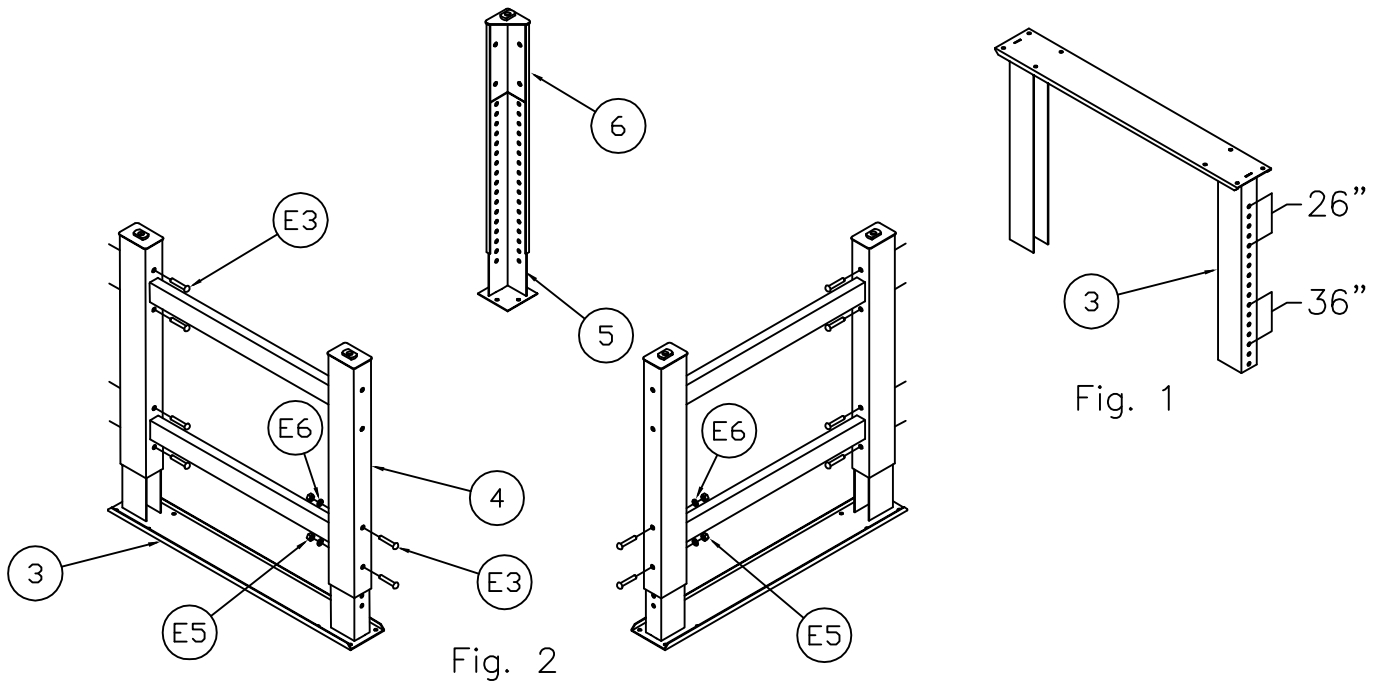

3. Assemble Spreaders (2) and Leg Assembly (3 & 4) and secure using Lock Washers (E6) and Nuts (E5). See Fig. 3

4. Assemble Corner Upper Leg (5), Corner Lower Leg (6) and Spreaders (2) at the same height as the Leg Assembly (3 & 4) using Screws (E4), Lock Washers (E6) and Nuts (E5). Do not tighten hardware at this time.

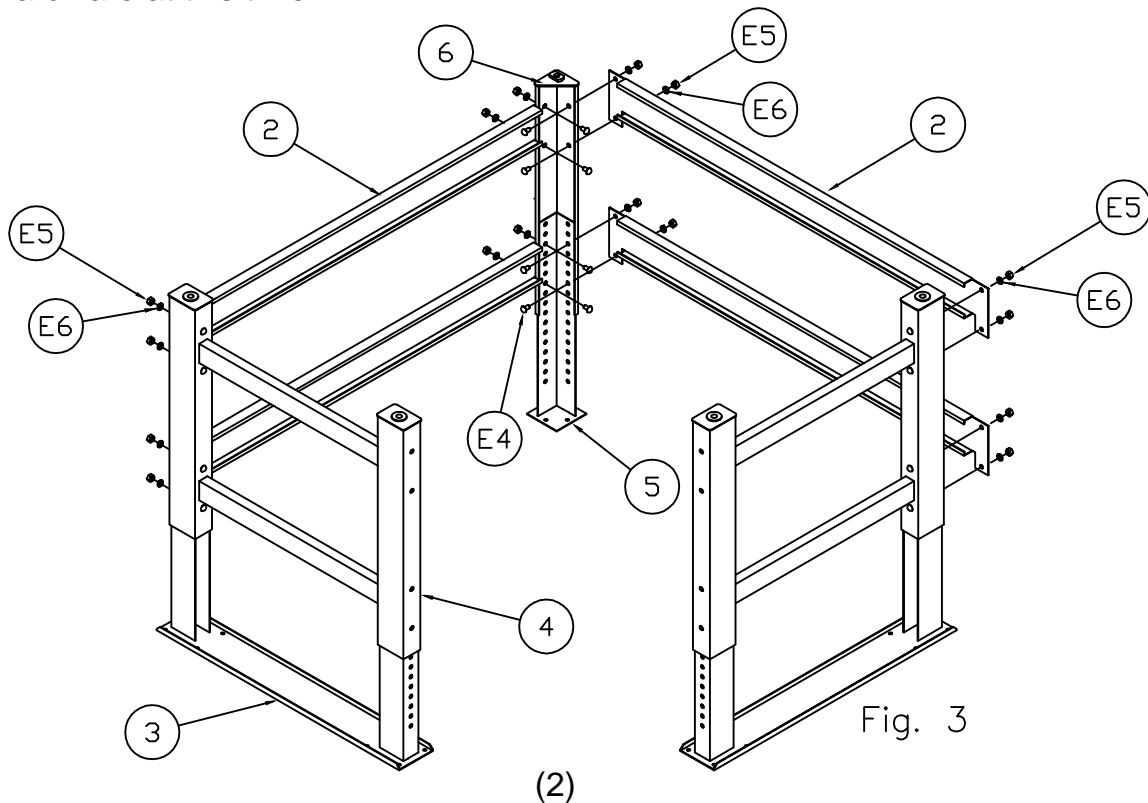

5. Place Top (1) upside-down. Place Leg Assembly onto Top. Align holes in Leg Assembly with inserts in Top. See Fig. 4

6. Attach Leg Assembly to Top using Screws (E1).

7. Screw Glides (E2) into threaded holes on Lower Legs.

8. Tighten all hardware.

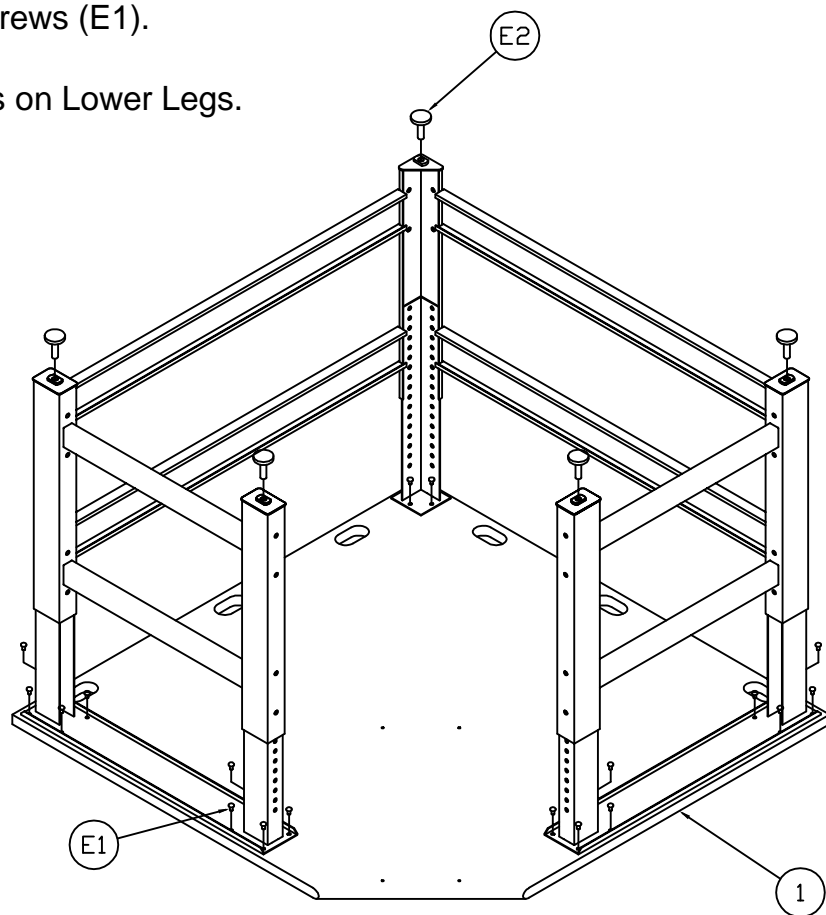

Fig. 4

9. Flip table.

10. Insert Hole Plugs (E6) into front of table legs (4x).

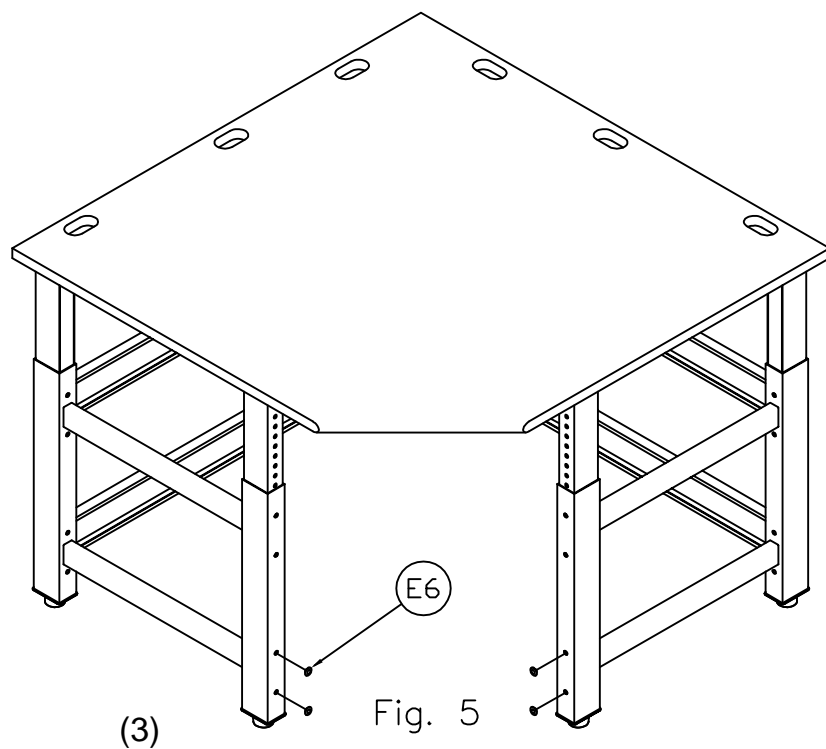

Fig. 5