

ASSEMBLY INSTRUCTIONS

CSII FREESTANDING PENINSULA

CATALOG No:

C625
C626
C627

C635
C636
C637

C645
C646
C647

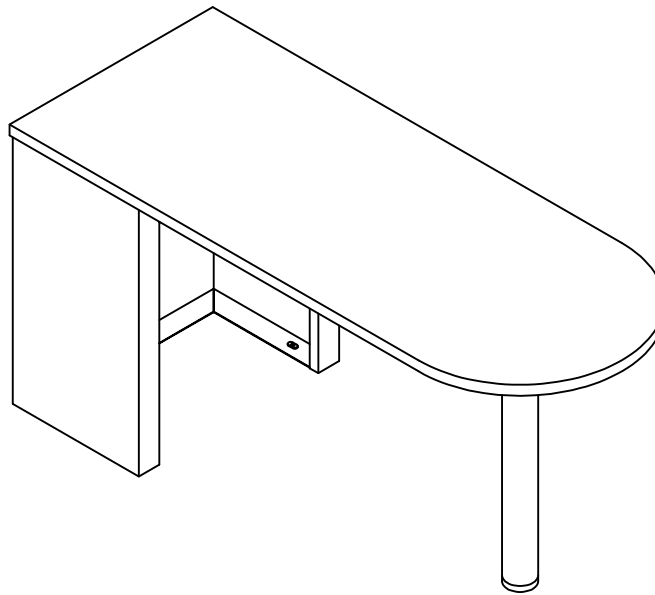

NOTE: Please count and inspect all pieces before disposing of any carton or packing materials.

COMPONENTS:

When ordering components, specific color and/or size information may be required. Contact a Mayline Customer Service Representative. 1-800-822-8037

<u>REF. #</u>	<u>QTY.</u>	<u>DESCRIPTION</u>	<u>PART No.</u>	
1	1	WORK SURFACE	CALL~~**	** Denotes Color Code
2	1	LEG	CALL~~**	~~Denotes Size
3	1	POST LEG	B5185	

HARDWARE BAG (PART No. A7646)

*for individual part, order that part number

<u>REF. #</u>	<u>QTY</u>	<u>DESCRIPTION</u>	<u>PART No.</u>
E1	12	#10 X 3/4 SCREW	X11*
E2	2	GLIDE	Q444*

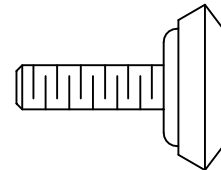
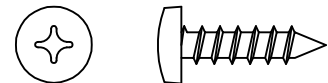

Freestanding Peninsula Assembly:

NOTE: Size may vary but assembly procedure remains the same.

1. Place the Work Surface (1) face down onto a clean, protected surface.
2. Position Leg (2) approximately 3/16 from the edges and align the holes in the Leg with the pre-drilled holes in the Work Surface. Attach Leg to Work Surface with seven Screws (E1).
3. Tighten all screws.
4. Install two Glides (E2) into Leg.
5. Align the holes in the Post Leg (3) mounting plate with the pre-drilled holes in the Work Surface. Secure the assembled Post Leg using four screws (E1).
6. Place the assembled peninsula in the upright position. MAYLINE recommends that a minimum of two people perform this task.
7. Place the peninsula at the location where it will be used. MAYLINE recommends that a minimum of two people perform this task.
8. Level the assembly by adjusting the glides.

Freestanding Peninsula Assembly:

NOTE: Size may vary but assembly procedure remains the same.

