

Monitor Supports

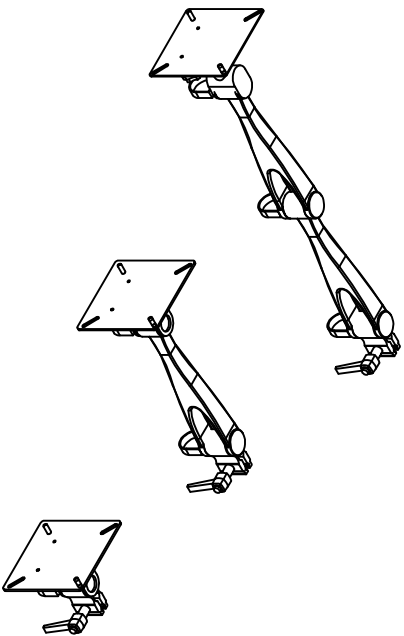



















Model No. TAM, TAM1 & TAM2



ASSEMBLY INSTRUCTIONS

CALL 1-800-822-8037 FOR ASSISTANCE

PARTS LIST

Name	Part	Qty	Part	Qty	Part	Qty
<b>A</b>	 <b>TAM</b> Monitor Support - No Arms	1	 <b>TAM1</b> Monitor Support - One Arm	1	 <b>TAM2</b> Monitor Support - Two Arms	1
<b>B</b>	 <b>TAMP</b> Monitor Plate	1	 <b>TAMP</b> Monitor Plate	1	 <b>TAMP</b> Monitor Plate	1
<b>C</b>	 Thumb Screw	2	 Thumb Screw	2	 Thumb Screw	2
<b>D</b>	 Cable Clip - Arm	1	 Cable Clip - Arm	2	 Cable Clip - Arm	3
<b>E</b>	 Cable Clip - Post	1	 Cable Clip - Post	1	 Cable Clip - Post	1
<b>F</b>	 Screw M3 x 8mm	4	 Screw M3 x 8mm	4	 Screw M3 x 8mm	4
<b>G</b>	 Washer - M3	4	 Washer - M3	4	 Washer - M3	4

Items with HB are in hardware box **TAMHB**.

- 1** Remove cap from post.
- 2** Slide monitor arm (A) into a groove at the desired position.
- 3** Tighten ratcheting lever.
- 4** Repeat Steps 2 & 3 with additional monitor arms, if necessary.
- 5** Re-install cap on top of post.

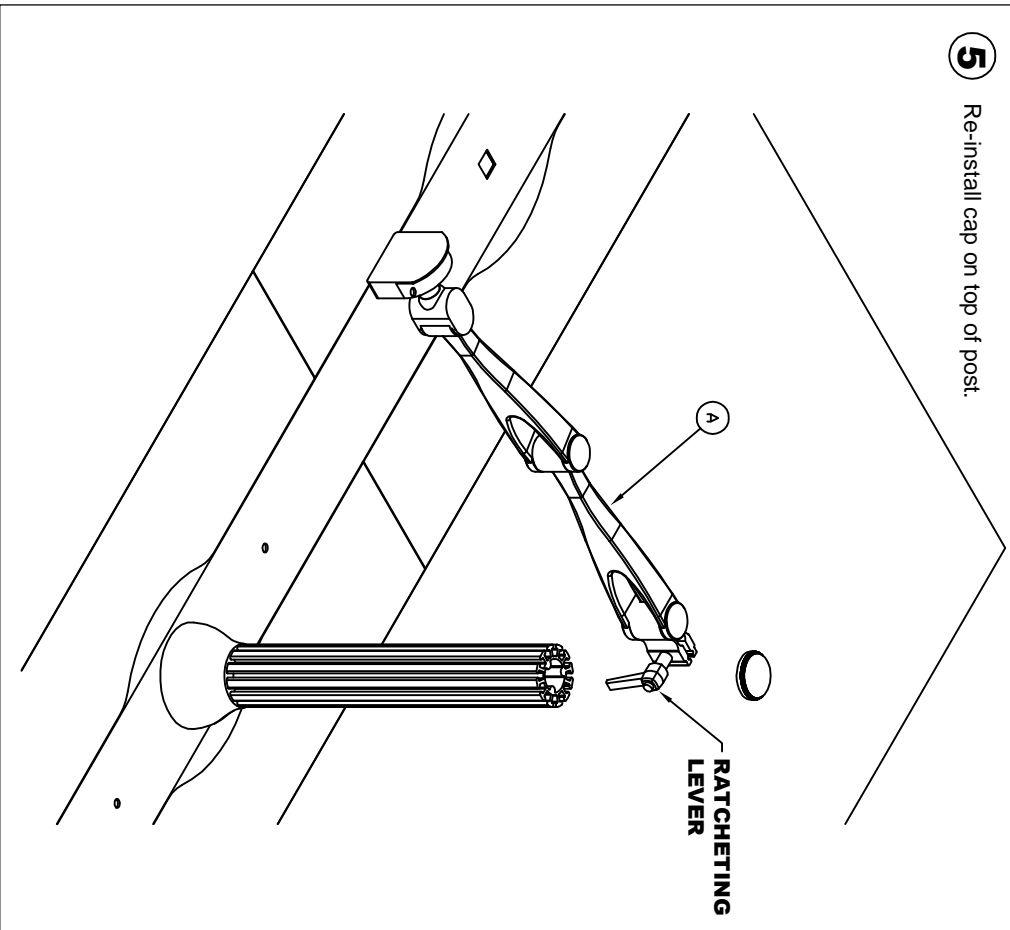

**3**

- 6** Attach plate (B) to rear of monitor using the screws provided with the monitor or screw and washer (F & G) in hardware bag. Keep the cut out orientated to the top of the monitor.

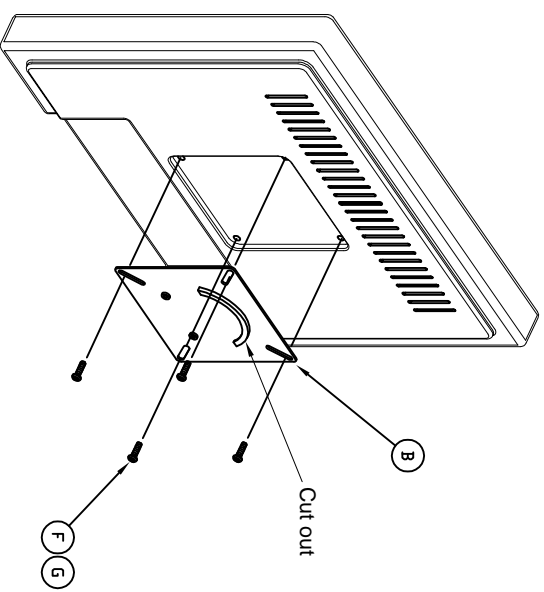

- 7** Place the cutout on plate (B) over lip on ball joint and secure using two finger screws (C) as shown.

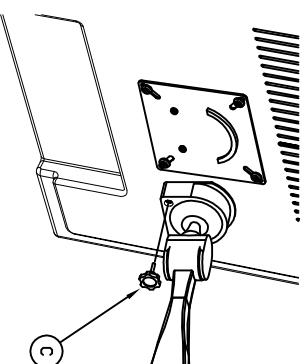

**4**

**8** Install cable management clips (D & E ) as desired.

