

# ASSEMBLY INSTRUCTIONS

## TRANSACTION FABRIC PANEL DIVIDERS

---

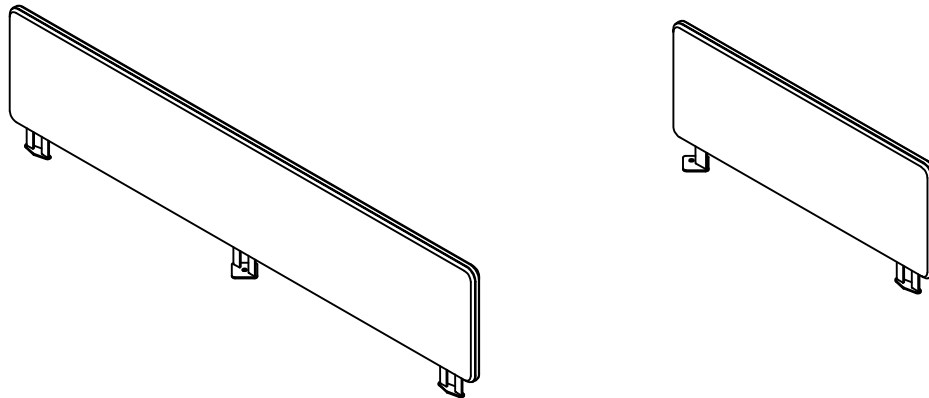

*NOTE: Please count and inspect all pieces before disposing of any carton or packing materials.*

### COMPONENTS:

When ordering components, specific color and/or size information may be require  
 Contact a Mayline Customer Service Representative. 1-800-822-8037

<u>REF. #</u>	<u>QTY.</u>	<u>DESCRIPTION</u>	<u>PART No.</u>
1	1	FABRIC PANEL	CALL~~**

2	1	IN LINE POST ASSEMBLY	A8058 **
---	---	-----------------------	----------



3	1	OFFSET POST ASSEMBLY	A8091 **
---	---	----------------------	----------



4	1/2	FRONT POST ASSEMBLY	A8090 **
---	-----	---------------------	----------



\*\* Denotes Color Code  
 ~~Denotes Size

### HARDWARE BAG (PART No. A8071) \*for individual item, order that part number

<u>REF. #</u>	<u>QTY</u>	<u>DESCRIPTION</u>	<u>PART No.</u>
E1	2	5/16-18 x 3/8"	X385*

(1)

**In-line Post Assembly  
used at the end of table.**

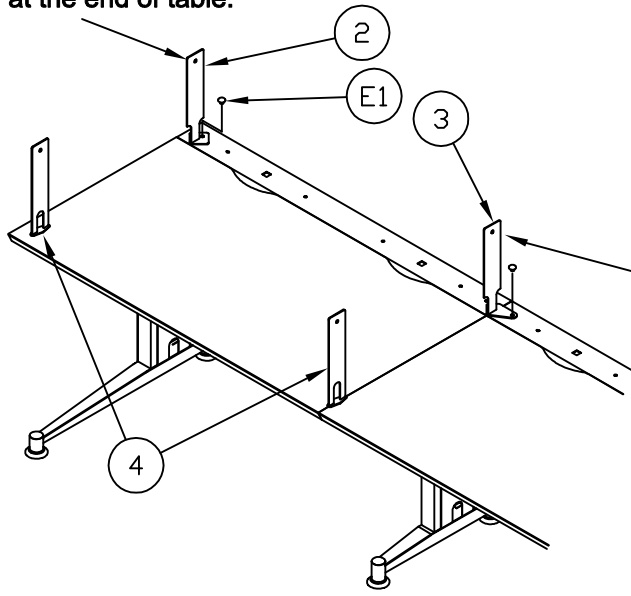

1. Install In-line Post Assembly (2) or Offset Post Assembly (3) in the desired location using Screws (E1).
2. Align Front Post Assemblies (4) with In-line or Offset Post Assemblies (E2 or E3).

**Offset Post Assembly  
used at the table seams.**

3. Slide Fabric Panel (1) onto Posts Assemblies (2, 3 or 4).

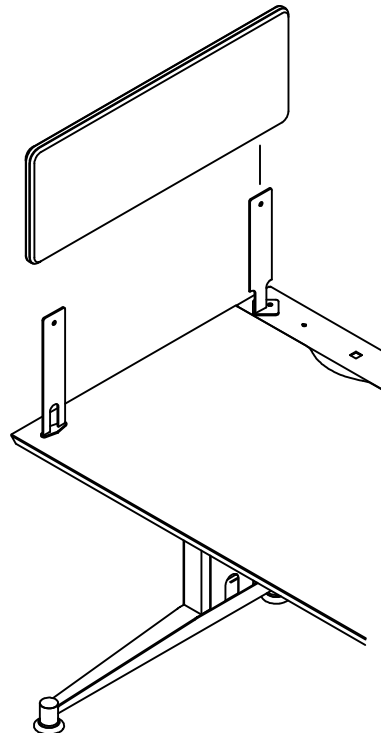

(2)

# ASSEMBLY INSTRUCTIONS

## TRANSACTION LATERAL FABRIC PANELS

---

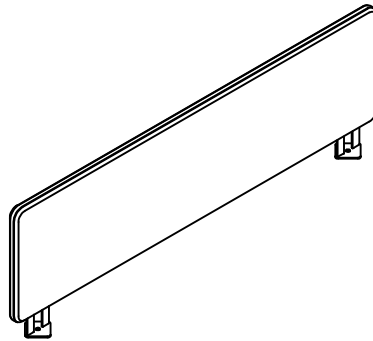

NOTE: Please count and inspect all pieces before disposing of any carton or packing materials.

### COMPONENTS:

When ordering components, specific color and/or size information may be require  
 Contact a Mayline Customer Service Representative. 1-800-822-8037

<u>REF. #</u>	<u>QTY.</u>	<u>DESCRIPTION</u>	<u>PART No.</u>
1	1	FABRIC PANEL	CALL~~**

2	2	POST ASSEMBLY	A8054**
---	---	---------------	---------



\*\* Denotes Color Code

~~Denotes Size

### HARDWARE BAG (PART No. A8071) \*for individual item, order that part number

<u>REF. #</u>	<u>QTY</u>	<u>DESCRIPTION</u>	<u>PART No.</u>
E1	2	5/16-18 x 3/8"	X385*

1. Post Assemblies (2) to the table beam in the desired location using Screws (E1).

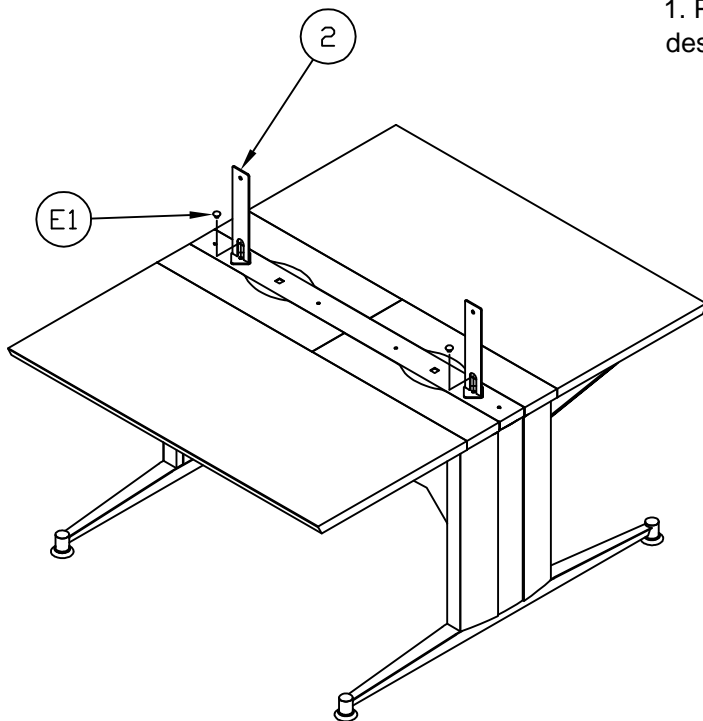

2. Slide Fabric Panel (1) onto Posts Assemblies (2).

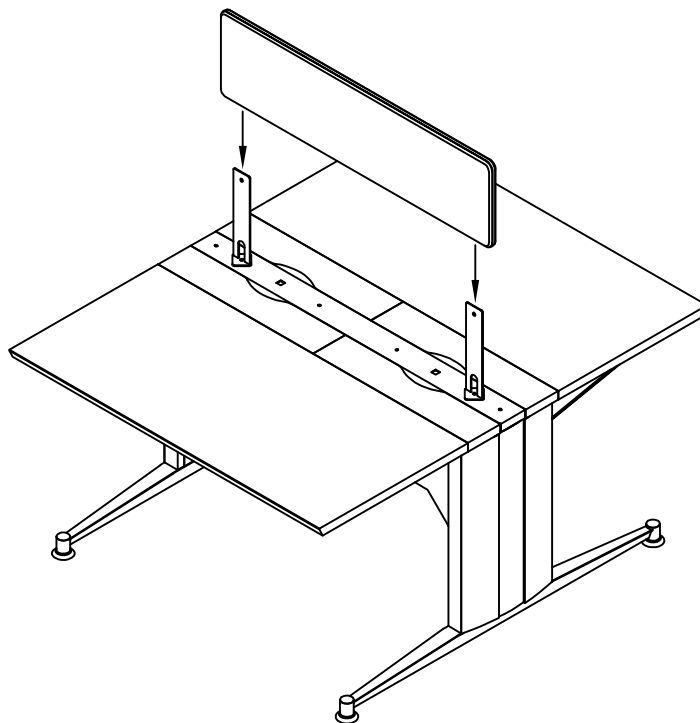

(4)