

# ASSEMBLY INSTRUCTIONS

## TRANSACTION DUAL STARTER

**NOTE:** Please count and inspect all pieces before disposing of any carton or packing materials.













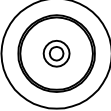
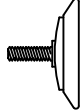



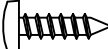

**COMPONENTS:** When ordering components, specific color and/or size information may be required. Contact a Mayline Customer Service Representative. 1-800-822-8037

Item #	QTY.	DESCRIPTION	PART #	Item #	QTY.	DESCRIPTION	PART #
1	2	LEG	A8043**	5	2	WORK SURFACE	Call~~**
2	1	BEAM ASSEMBLY	Call~~**	6	0/4/6	ACCESS PANEL	Call~~**
3	2	TROUGH SIDE	Call~~**	7	2	OUTER LEG PANEL	TADEP**
4	1	PAN	Call~~**	8	2	INNER LEG PANEL	B8219**

\*\* Denotes Color Code

~~Denotes Size

**HARDWARE BAG (PART No. A8076)** \* for individual item, order that part number

Item #	QTY	DESCRIPTION	PART #		
E1	4	TUBE INSERT, 5/16-18	T139*		
E2	4	GLIDE	Q608*		
E3	13	SCREWS #10-32 x 1/2"	X204*		
E4	4	WASHER, EXT STAR #10	W38*		
E5	28	SCREW #10 x 3/4	X11*		
E6	3	PLUG, SQUARE HOLE	F782*		
E7	2	SLAM LATCH	Q643*		
E8	2	BUSHING	F764*		
E9	8	RATCHET FASTENER	F483*		
E10	4	PINE TREE CLIP	F529*		



# WORKSURFACE HARDWARE

## TADT48, TADT60, TADT72: DUAL TRANSACTION "without" ACCESS PANELS

No additional hardware is required with these products.

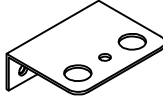

## TADT48S DUAL TRANSACTION STARTER "with" ACCESS PANELS

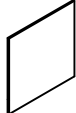
### HARDWARE BAG (PART No. A8117) \* for individual item, order that part number

<u>Item #</u>	<u>QTY</u>	<u>DESCRIPTION</u>	<u>PART #</u>	
E11	4	ANGLE, MOUNTING	B8267*	
E12	9	SCREWS #10-32 x 1/2"	X204*	
E13	8	DOWEL PIN. PLASTIC	F783*	
E14	8	2" X 2" SPACER	E544*	

## TADT60S, TADT72S DUAL TRANSACTION STARTER "with" ACCESS PANELS

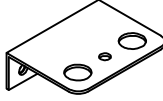
### HARDWARE BAG (PART No. A8119) \* for individual item, order that part number

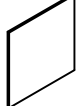
<u>Item #</u>	<u>QTY</u>	<u>DESCRIPTION</u>	<u>PART #</u>	
E11	8	ANGLE, MOUNTING	B8267*	
E12	17	SCREWS #10-32 x 1/2"	X204*	
E13	12	DOWEL PIN. PLASTIC	F783*	
E14	12	2" X 2" SPACER	E544*	

**NOTE:**

If the desired configuration utilizes multiple adders, substitute one Adder Leg (TADAL\*\*).

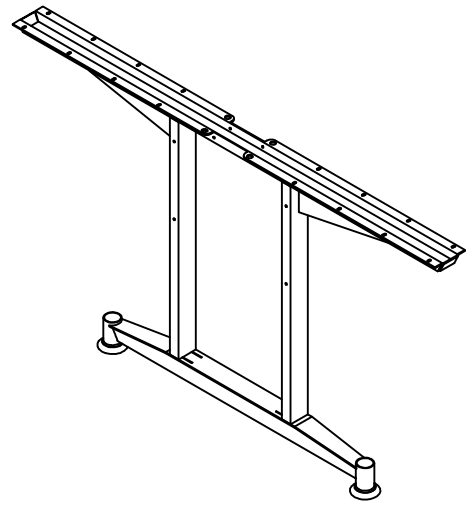

1. Install tube inserts (E1) into legs (1).  
NOTE: Substitute Adder Leg (TADAL\*\*) for one Leg (1) when final configuration utilizes multiple adders.
2. Screw glide (E2) into inserts.

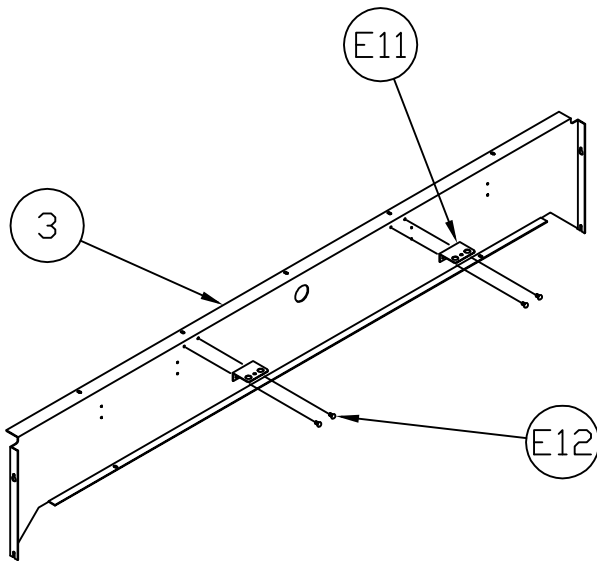
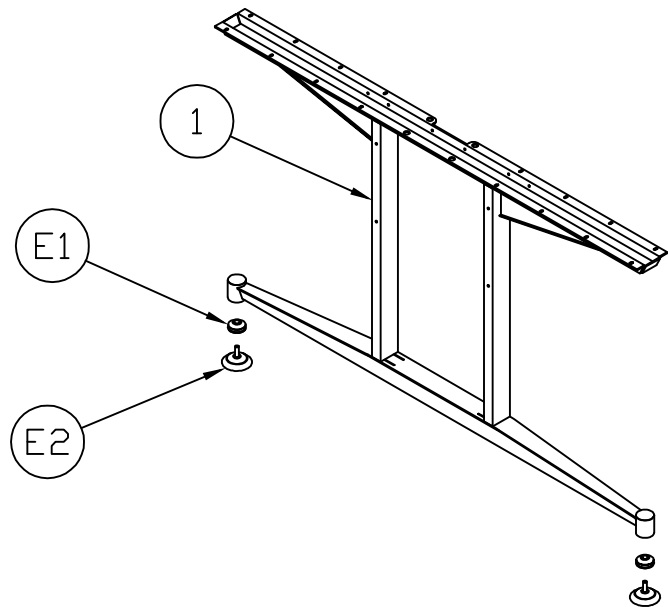

NOTE: The illustrations shown here reflect a 60"W or 72"W table. If installing a 48"W, part quantities may vary.

NOTE: If installing a table without access panels (6), proceed to Step 4.

3. Attach mounting angles (E11) to trough side (3) using screws (E12).

4. Install screws (E3) to the inside of leg (the side opposite gusset flange), leaving approximately 1/8" between screw head and leg tube.
5. Using slots in trough sides (3), hook trough sides onto screw heads on both legs. DO NOT TIGHTEN SCREWS.

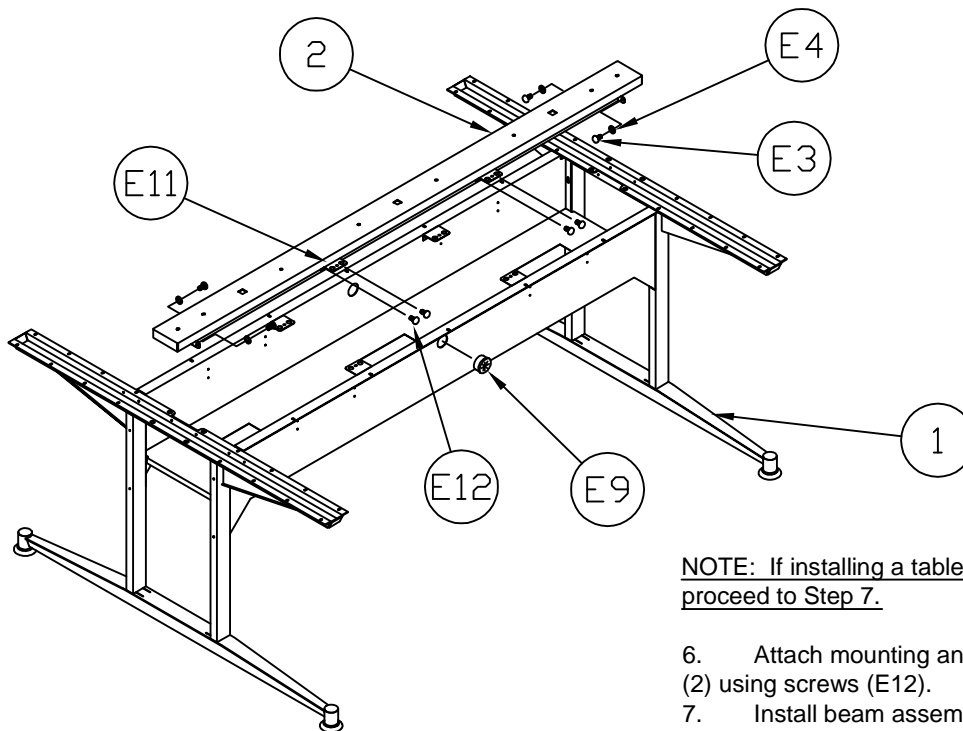
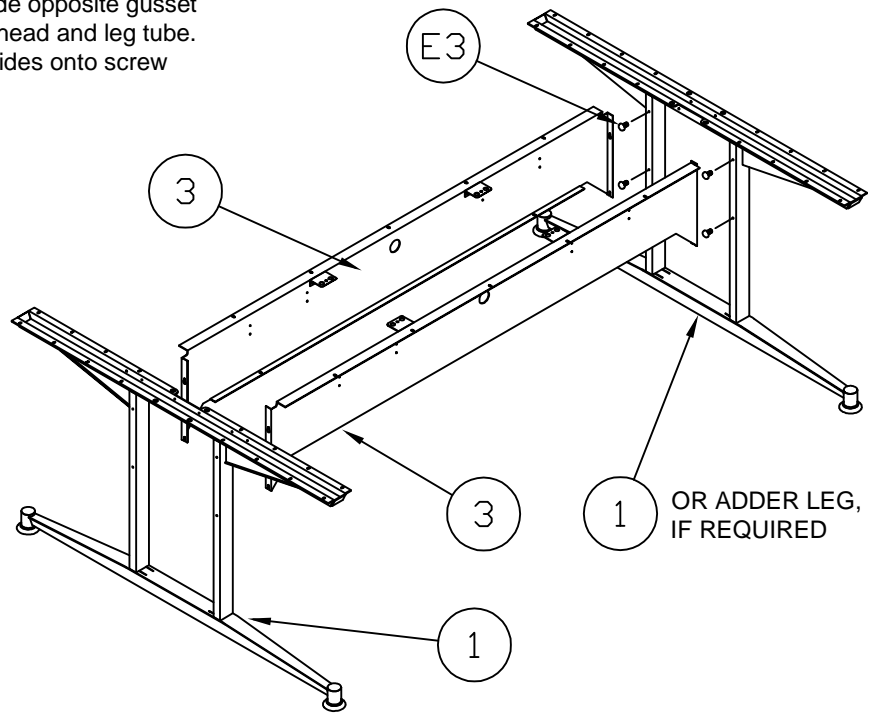
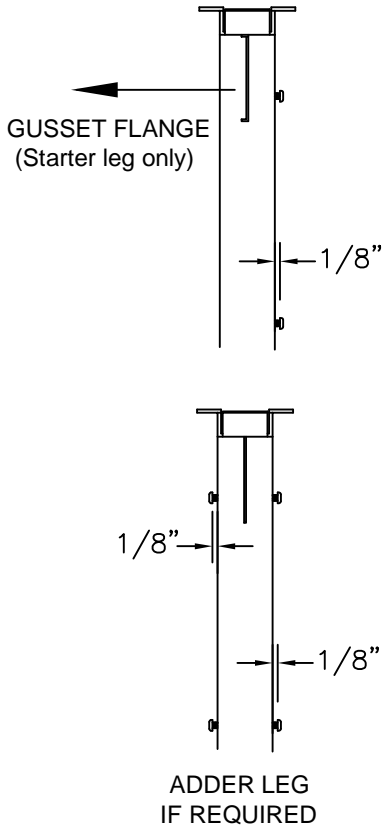

**NOTE:** If installing a table without access panels (6), proceed to Step 7.

6. Attach mounting angles (E11) to beam assembly (2) using screws (E12).
7. Install beam assembly (2) from above. Place beam (2) between legs (1) by tipping the beam into the leg flange notch. Secure beam (2) with screws (E3) and washers (E4).
8. Insert bushing (E8) into trough side (3).
9. Tighten all screws (E3) at this time.

10. Lay pan (4) onto trough side flanges (3). Secure pan (4) to trough sides (3) using pine tree clips (E10).
11. Install slam latch (E7) into inner leg panel slot (8) as shown.
12. Insert tabs in the bottom of inner leg panel (8) into slots in foot. Rotate inner leg panel (8) up so that slam latch catches flange on pan (4).
13. Install outside leg panels (7) by aligning the one flange with the inside edge of the tube and applying pressure to create a curve in the end panel that allows 2nd flange to slide inside edge of tube.
14. Insert square hole plugs (E6) and ratchet fastener (E9) into holes in beam. NOTE: This step should be done after privacy panels or monitor posts are installed in the beam.

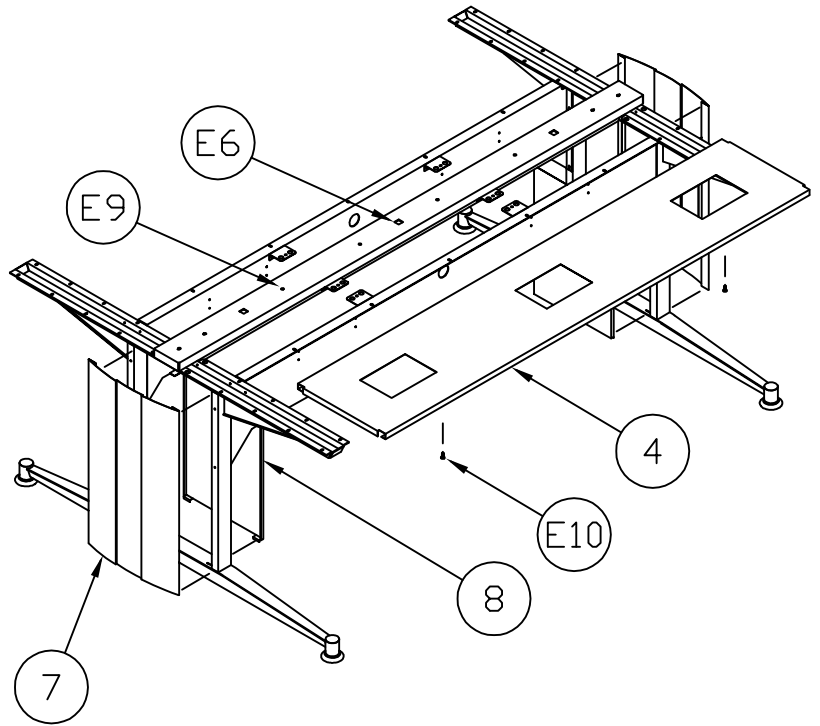
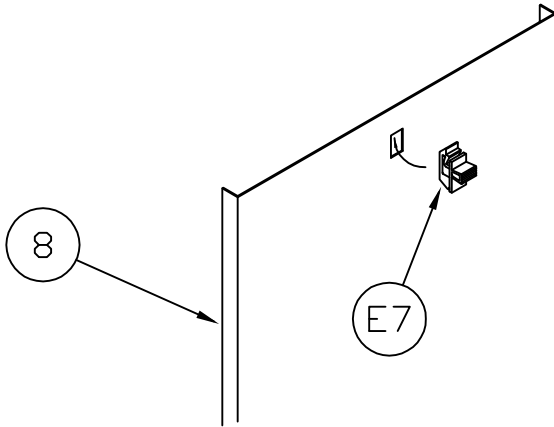

For tables "WITHOUT" Access Panels (6).

15. Position work surface (5) without access panels and secure with screws (E5).

For tables "WITH" Access Panels (6).

15. Insert dowels (E13) into holes in access panels (6) as shown below. NOTE: For 48" W tables use the positions shown in the far left and right of the view below.
16. Lay access panels (6) onto table frame so that dowels engage holes in mounting angle.
17. Insert spacers (E14) between access panels and work surfaces as shown (2 per access panel).
18. Position work surfaces and secure with screws (E5). Remove spacers.

