

ASSEMBLY INSTRUCTIONS

TRANSACTION

BASIC 6' ADDER TABLE











NOTE: Please count and inspect all pieces before disposing of any carton or packing materials.

COMPONENTS: When ordering components, specific color and/or size information may be required. Contact a Mayline Customer Service Representative. 1-800-822-8037

Item #	QTY.	DESCRIPTION	PART #
1	1	LEG, ADDER	A8132**
2	2	MODESTY PANEL	B8416**
3	1	WORKSURFACE	L7219**
4	2	PANEL, CONF. LEG	B8411**

** Denotes Color Code

HARDWARE BAG (PART No. A8128) * for individual item, order that part number

Item #	QTY	DESCRIPTION	PART #		
E1	2	TUBE INSERT, 5/16-18	T139*		
E2	2	GLIDE	Q608*		
E3	8	SCREWS #10-32 x 1/2"	X204*		
E4	28	SCREW #10 x 3/4	X11*		
E5	2	SLAM LATCH	Q643*		

1. Install threaded inserts (E1) into Adder Leg (1).
2. Thread Glides (E2) into threaded inserts installed in Step 1.

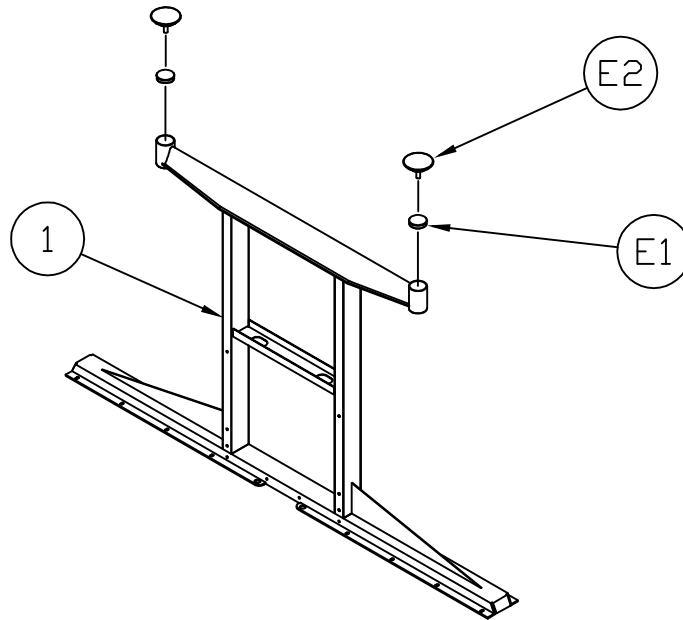

3. Partially install Screws (E3) into the second holes from the top and the bottom holes on **both sides** of the Adder Leg so that the screw heads are approximately 1/8" from the leg.

4. Using the key hole slots in the ends of the Modesty Panels (2), attach the Panels to Adder Leg. TIGHTEN FOUR SCREWS holding panels at this time.

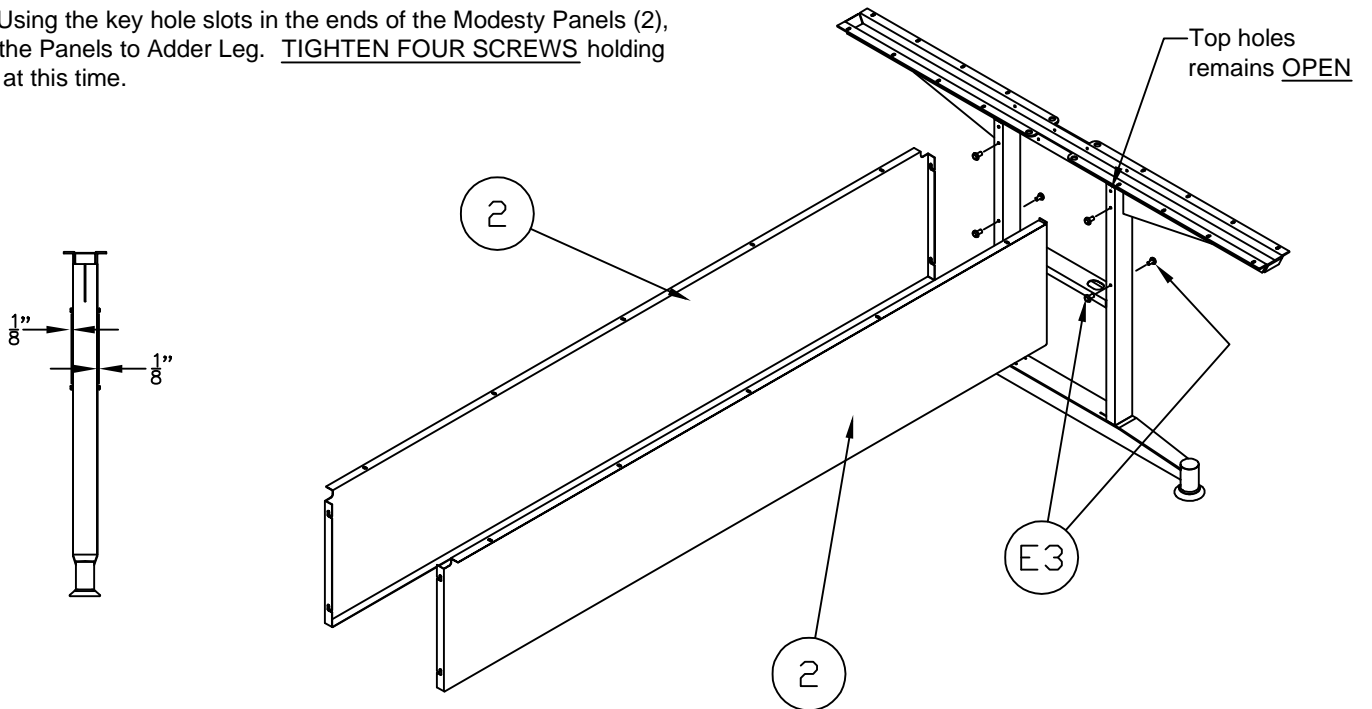

5. Assemble Starter Base per instructions included with that product.

6. Move assembled Adder Base into position. Using the key hole slots in the ends of the Modesty Panels (2), attach the Panels to the assembled Starter Base. TIGHTEN FOUR SCREWS holding panels at this time.

7. Continue the Conference Table assembly by joining another Adder Base or complete the Conference Table by joining the final section.

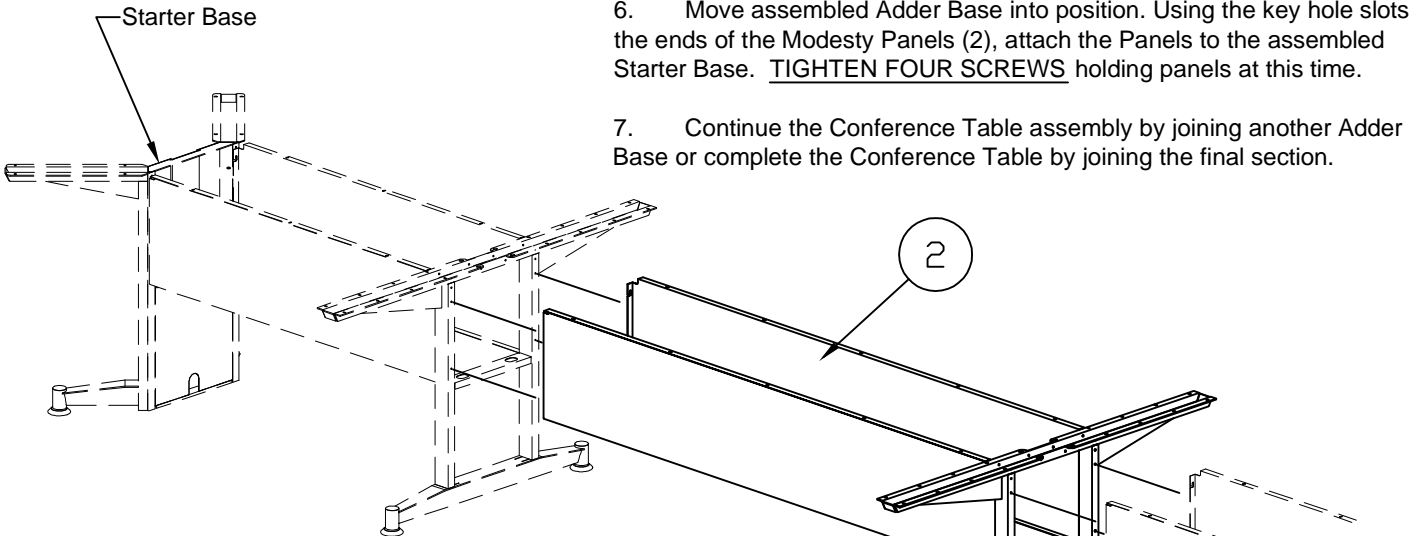

8. Position Starter Worksurface over Starter Base and loosely fasten in place using hardware and instructions supplied with that product. Position Adder Worksurface (3) on Adder Base and loosely fasten using Screws (E4) through leg and side panels.

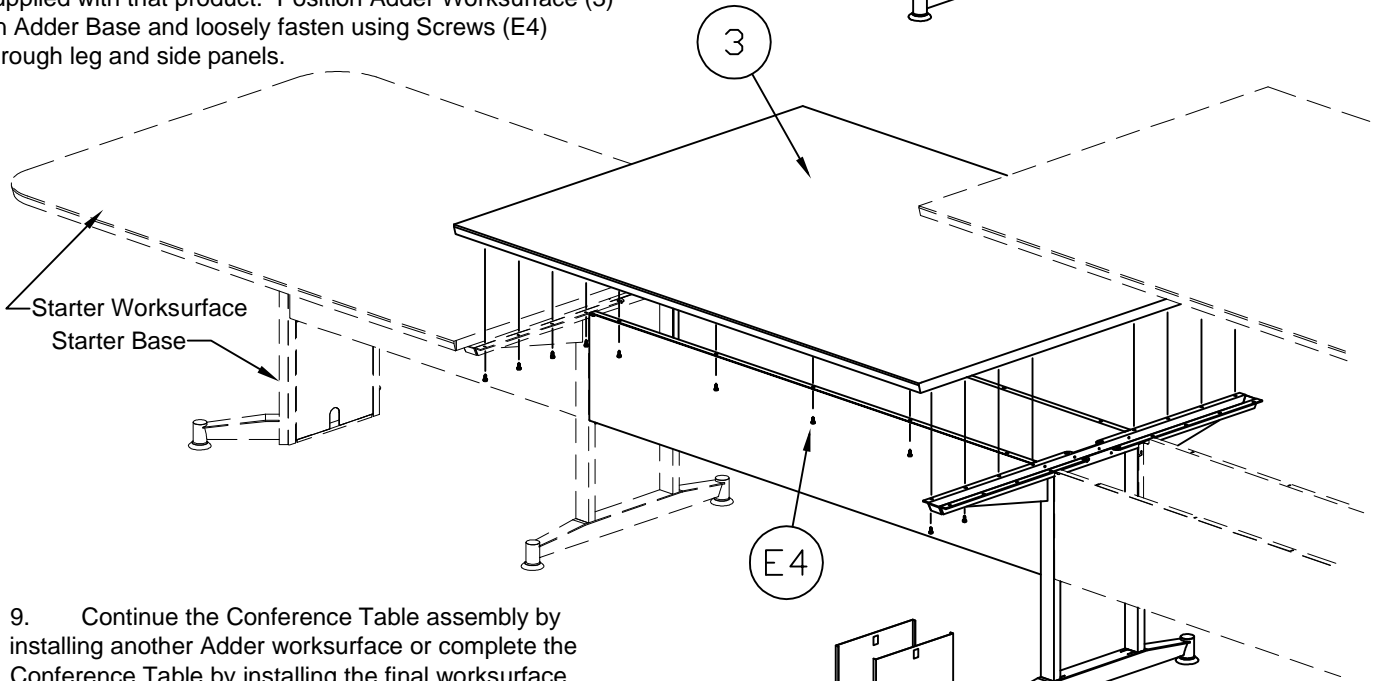

9. Continue the Conference Table assembly by installing another Adder worksurface or complete the Conference Table by installing the final worksurface.

Once **ALL** tops are installed and aligned, tighten all screws.

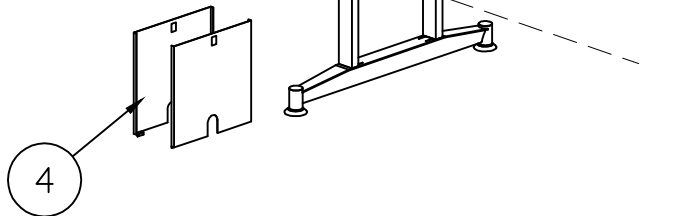
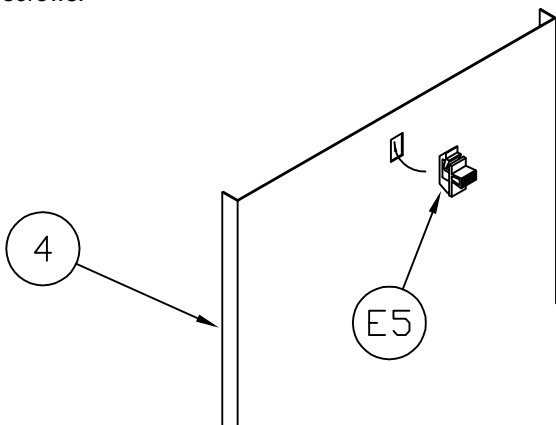

10. Install Slam Latch (E5) into Leg Panel (4) cutout as shown.

11. Insert Leg Panel (4) into Adder Leg slots. Rotate Leg Panel till slam latches catch.

(3)