

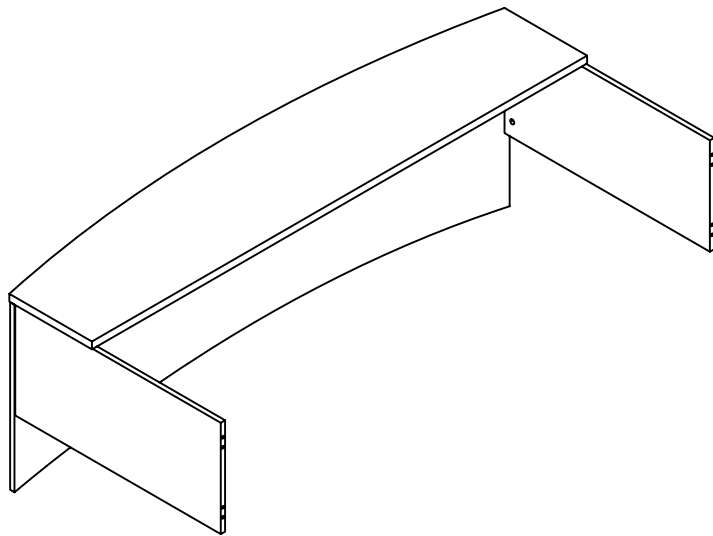

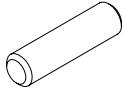



Brighton Series™
 Reception Counter
 Model No. BTRDTC

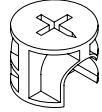

ASSEMBLY INSTRUCTIONS
CALL 1-800-822-8037 FOR ASSISTANCE

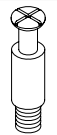
PARTS LIST

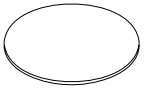
Name	Part	Qty.	Spare Qty	Name	Part	Qty.	Spare Qty
A	 REALS004 Wood Dowel	6	1	E	 REALS103** Cam Sticker 12mm	4	1
B	 REALS001 Cam	12	1	F	 REALS248 Foam Tape	2	
C	 REALS002 Cam Post	12	1		 BTRDTCB		
D	 REALS102** Cam Sticker	12	1				

Items with HB are in hardware box.
 **Denotes Color Code

PARTS LIST

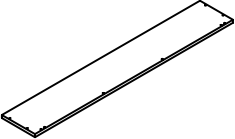
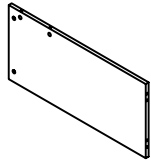
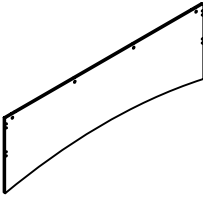
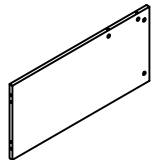
Name	Part	Qty.	Name	Part	Qty.
K	 BTRDTCK** Top	1	M1*	 BTRDTCSP** Right Side Panel	1
L	 BTRDTCL** Fascia	1	M2*	 BTRDTCSP** Left Side Panel	1

*NOTE: When ordering replacement Side Panels (BTRDTCSP**) you will receive both R.H. and L.H. Panels

**Denotes Color Code

2

- 1** Insert Wood Dowels (A) into ends of the Side Panels (M1 & M2). Insert Cams (B) into the Side Panels (M1 & M2). Install Cam Posts (C) into threaded inserts in Fascia (L). Attach Side Panels (M1 & M2) to Fascia (L) by turning Cams (B).

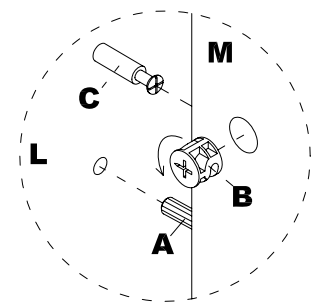
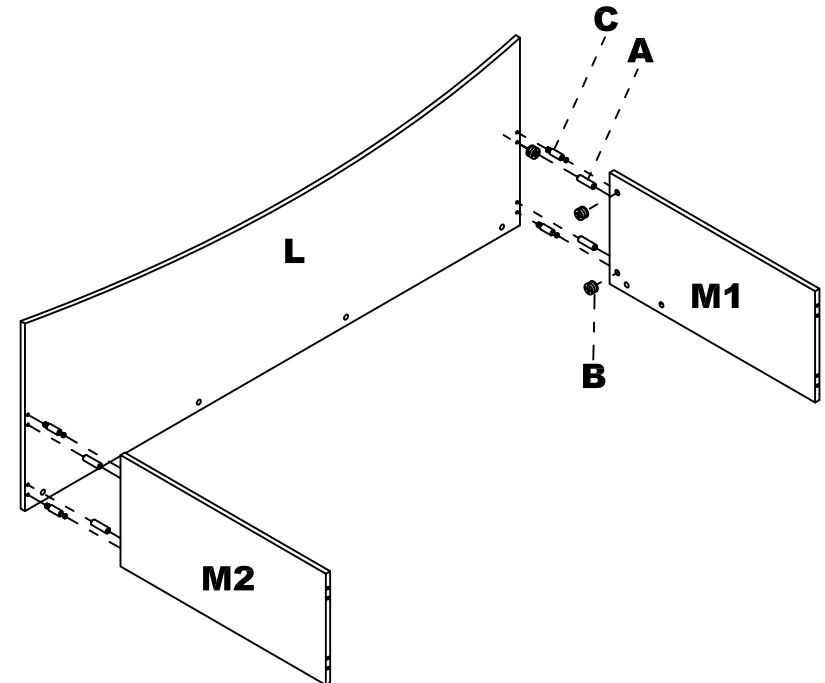

NOTE: The arrow on the face of the Cam (C) should point towards the Cam Post (B) for proper alignment.

3

- ② Flip assembled frame and temporarily position onto the desk.

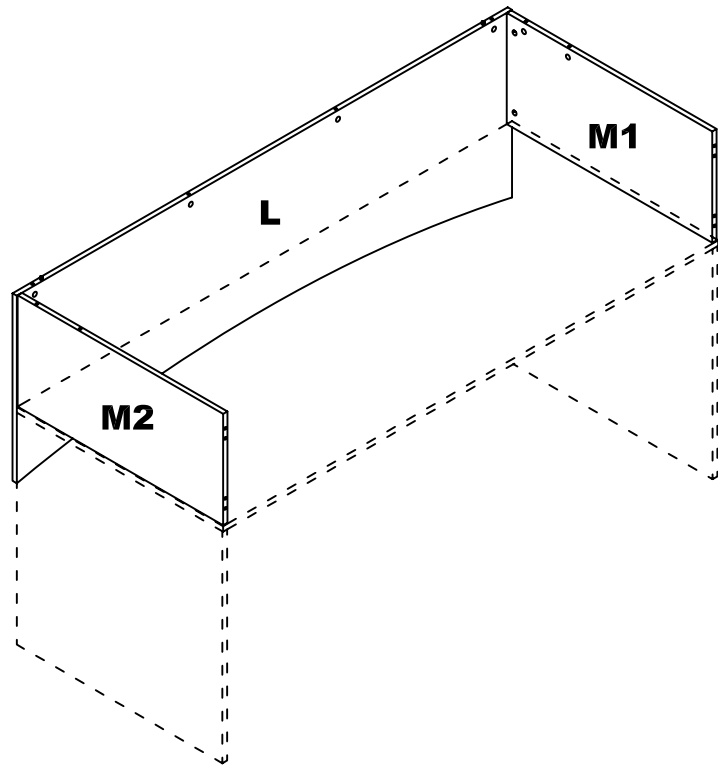

4

- ③ Install Cam Posts (C) into threaded inserts in underside of Top (K).

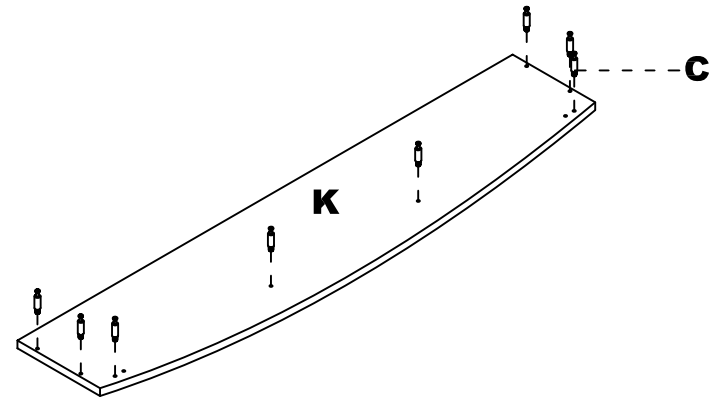

5

4

Insert Dowels (A) into edge of Fascia. Insert Cams (B) into Fascia (L) and Side Panels (M1 & M2). Attach Top (K) to Fascia (L) and Side Panels (M1 & M2) by turning Cams (B). Apply Cam Stickers (D) to Cams (B). Adhere Cam Stickers (E) to holes on end of Side Panels (M1 & M2).

Tilt Reception Counter forward and remove protective backing from tape (F) on bottom of Side Panels (M1 & M2). Center Reception Counter on Desk and press in place.

