

ASSEMBLY INSTRUCTIONS

MEETING PLUS TABLES

NOTE: Please count and inspect all pieces before disposing of any carton or packing materials.

COMPONENTS

When ordering components, specific color and/or size information may be required. Contact a Mayline Customer Service Representative. 1-800-822-8037

<u>REF#</u>	<u>QTY.</u>	<u>DESCRIPTION</u>	<u>PART NO.</u>	
1	1	Top	CALL ~**	** Denotes Color Code
2	1	Modesty Panel	CALL ~**	~~Denotes Size
3	2	Leg Assembly	CALL ~**	

HARDWARE BAG (Part No. A7922**)

<u>REF#</u>	<u>QTY.</u>	<u>DESCRIPTION</u>	<u>PART NO.</u>	
E1	16	Screw, 1/4-20	700124 *	* Individual Items, Order by part number.
E2	2	Caster Wheel	700229 *	
E3	2	Caster Axle	700230 *	
E4	2	Swivel Glide	700169 *	
E5	4	End Cap	600109** *	
E6	4	Screw, #10 x 3/4"	X11 *	
E7	2	Grommet Edging	F682*	
E8	12	Washer, 9/32 x 1 x .06	W83	

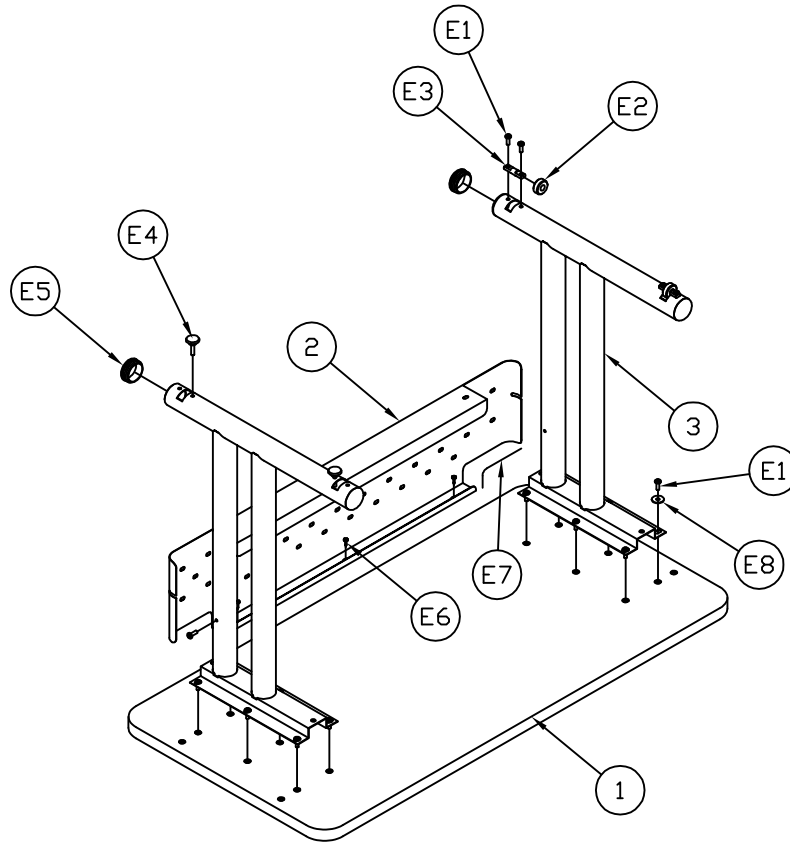

MAYLINE®

Mayline Company, LLC
 619 N. Commerce, P.O. Box 728
 Sheboygan, WI 53082-0728
 Toll Free: 1-800-822-8037
 FAX: 920-457-7388
 On Line: www.mayline.com

Assembly:

1. Assemble Glides (E4) into inner most threaded holes in Leg (3). Install End Caps (E5) into Leg (3). See Fig.#
2. Slide the Axle (E3) into the Wheel (E2) and attach Axle (E3) to Leg Assembly (3) using Screws (E1). See Fig. #2
3. Attach the Grommet Edging (E7) to Modesty Panel (2) on each end. See Fig. #3

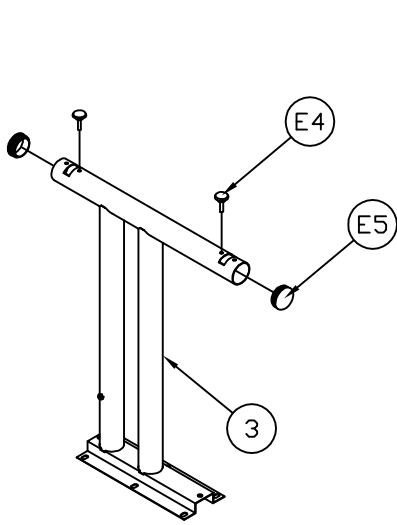

Fig. #1

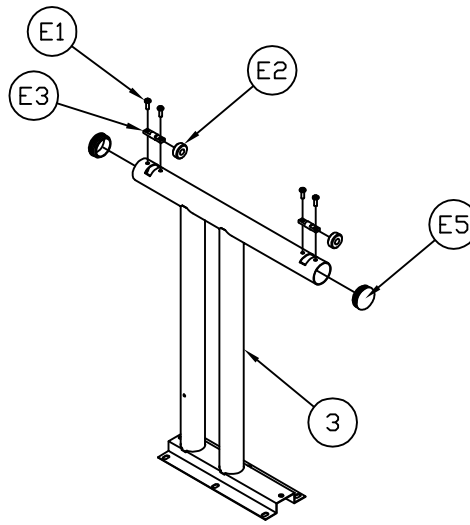

Fig. #2

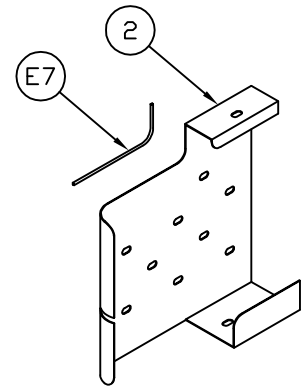

Fig. #3

4. Place Top (1) face down on a clean flat surface. Attach Leg Assembly (3) onto Top using six Screws (E1) & six Washers (E8) per Leg. See Fig. #4 DO NOT TIGHTEN AT THIS TIME.

5. Attach Modesty Panel (2) to Leg Assembly using one Screw (E1) per Leg.

Note: Screws are pre-assembled into leg during manufacturing. May need to move screw to other side of Leg. See Fig. #5.

6. Tighten all Screws (E1).

7. Attach Modesty Panel to Top using Screws (E6). No pilot hole necessary. See Fig. #5

Tip: On multiple tables always assemble the same leg on the same side. When the tables are next to each other you have wheels on one leg and levelers on the other.

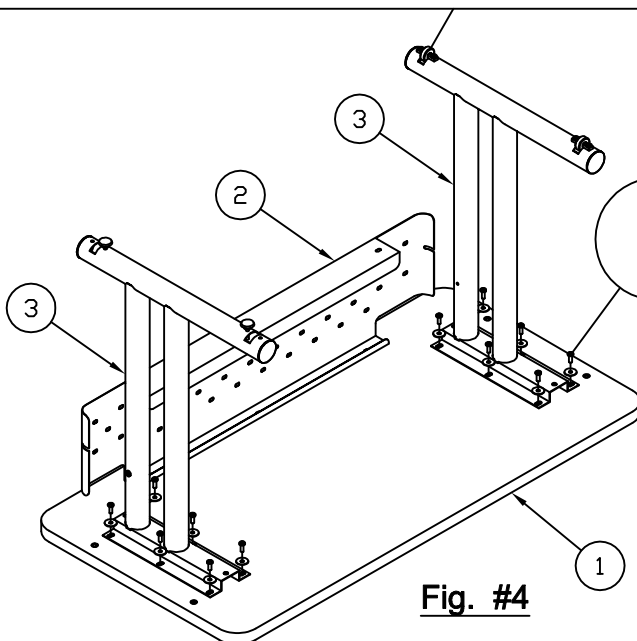

Fig. #4

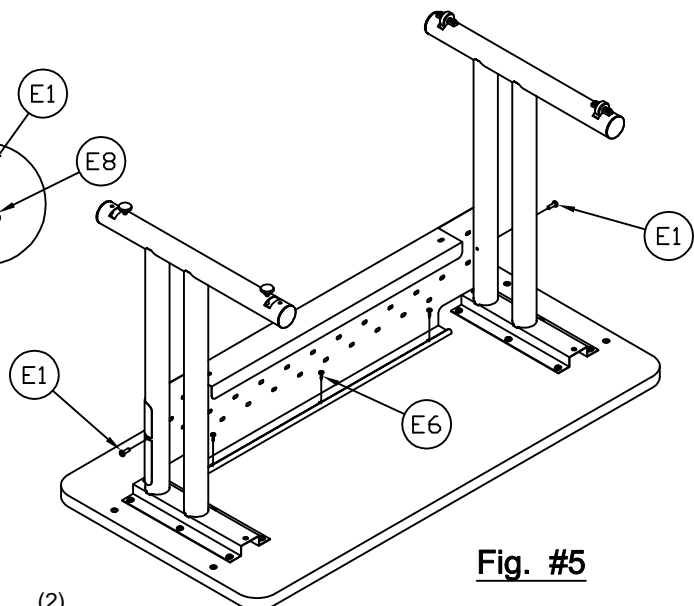
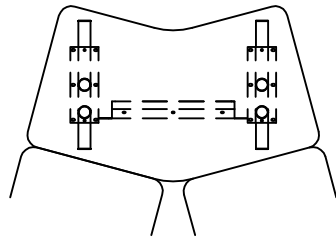

Fig. #5

Transition Table Assembly Only (Conference vs. Stadium)

Note: Modesty Panel location has two options for assembly.

1. Begin Assembly by determining if the table will be used as Conference or Stadium position. See Fig. #6
2. Follow Instructions on page 2, Steps 1 - 7



Conference position

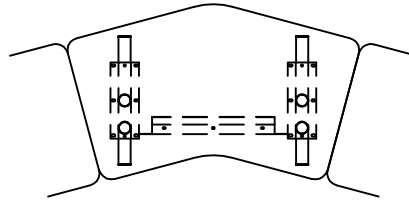

Stadium position

Fig. #6

Extra inserts on the underside of the top are for optional ganging kit 10GA & Pie connectors.

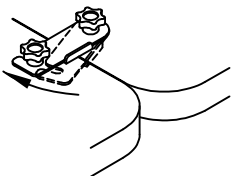

10GA Ganging Kit

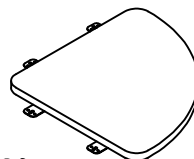

90°
Pie Connector



45°
Pie Connector



30°
Pie Connector