

ASSEMBLY INSTRUCTIONS

TRANSACTION DUAL ADDER

NOTE: Please count and inspect all pieces before disposing of any carton or packing materials.

COMPONENTS: When ordering components, specific color and/or size information may be required. Contact a Mayline Customer Service Representative. 1-800-822-8037













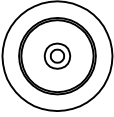
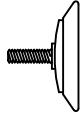





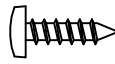

Item #	QTY.	DESCRIPTION	PART #	Item #	QTY.	DESCRIPTION	PART #
1	1	LEG, ADDER	A8046**	5	2	WORK SURFACE	Call~~**
2	1	BEAM ASSEMBLY	Call~~**	6	0/4/6	ACCESS PANEL	Call~~**
3	2	TROUGH SIDE	Call~~**	7	2	INNER LEG PANEL	B8219**
4	1	PAN	Call~~**	8	2	ANGLE, TOP JOINING	B8224**

** Denotes Color Code
~~Denotes Size

HARDWARE BAG (PART No. A8100)

* for individual item, order that part number

** HARDWARE BAG LOCATED IN BEAM ASSEMBLY **

Item #	QTY	DESCRIPTION	PART #		
E1	2	TUBE INSERT, 5/16-18	T139*		
E2	2	GLIDE	Q608*		
E3	13	SCREWS #10-32 x 1/2"	X204*		
E4	4	WASHER, EXT STAR #10	W38*		
E5	25	SCREW #10 x 3/4	X11*		
E6	6	SCREW #10 x 1	X12*		
E7	3	PLUG, SQUARE HOLE	F782*		
E8	2	SLAM LATCH	Q643*		
E9	2	BUSHING	F764*		
E10	8	PINE TREE CLIP	F483*		
E11	4	PINE TREE CLIP	F529*		



619 N. Commerce, P.O. Box 728, Sheboygan, WI 53082-0728
www.mayline.com 800-822-8037 Fax 920-457-7388

WORK SURFACE HARDWARE

TADT48, TADT60, TADT72: DUAL TRANSACTION "without" ACCESS PANELS



No additional hardware is required with these products.

TADT48A DUAL TRANSACTION STARTER "with" ACCESS PANELS

HARDWARE BAG (PART No. A8119)

* for individual item, order that part number

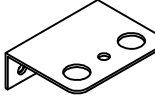
** HARDWARE BAG LOCATED IN TOP ASSEMBLY **

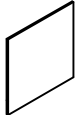

<u>Item #</u>	<u>QTY</u>	<u>DESCRIPTION</u>	<u>PART #</u>	
E12	8	ANGLE, MOUNTING	B8278*	
E13	17	SCREWS #10-32 x 1/2"	X204*	
E14	12	DOWEL PIN. PLASTIC	F783*	
E15	12	2" X 2" SPACER	E544*	

TADT60A, TADT72A DUAL TRANSACTION STARTER "with" ACCESS PANELS

HARDWARE BAG (PART No. A8120)

* for individual item, order that part number

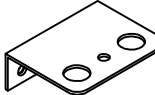
** HARDWARE BAG LOCATED IN TOP ASSEMBLY **

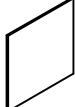
<u>Item #</u>	<u>QTY</u>	<u>DESCRIPTION</u>	<u>PART #</u>	
E12	12	ANGLE, MOUNTING	B8278*	
E13	25	SCREWS #10-32 x 1/2"	X204*	
E14	12	DOWEL PIN. PLASTIC	F783*	
E15	12	2" X 2" SPACER	E544*	

1. Install tube inserts (E1) into leg (1).
2. Screw glide (E2) into inserts.

NOTE: If the desired configuration utilizes multiple adders, substitute an adder leg for the right hand starter leg shown in the following steps.

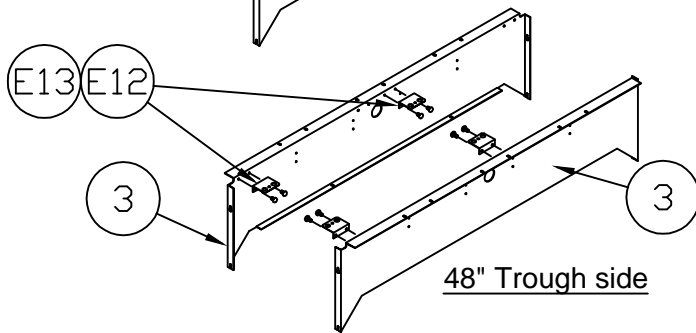
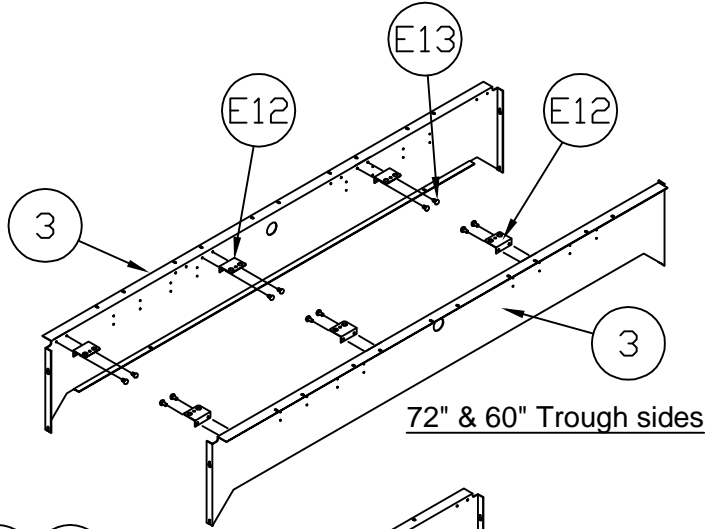
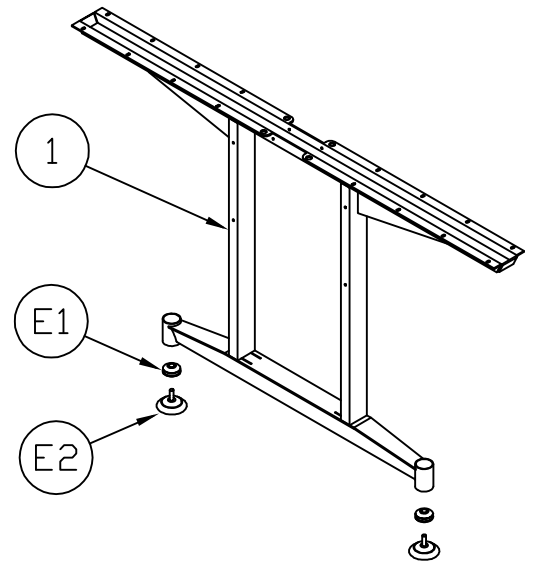

NOTE: The illustrations shown here reflect a 60\"W or 72\"W table. If installing a 48\"W, part quantities may vary.

NOTE: If installing a table without access panels (6), proceed to Step 4.

3. Attach mounting angles (E12) to trough side (3) using screws (E13).

4. Install screws (E3) to the inside of leg (the side opposite gusset flange), leaving approximately 1/8\" between screw head and leg tube.
5. Using slots in trough sides (3), hook trough sides onto screw heads on both legs. **DO NOT TIGHTEN SCREWS.**

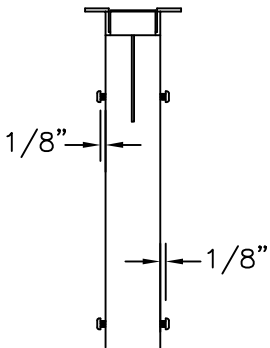
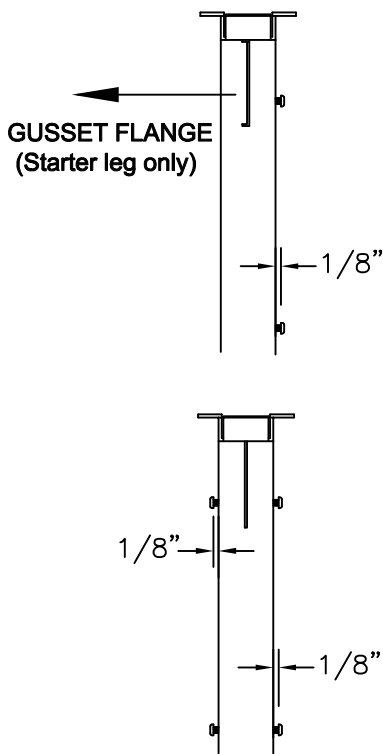

**ADDER LEG
IF REQUIRED**

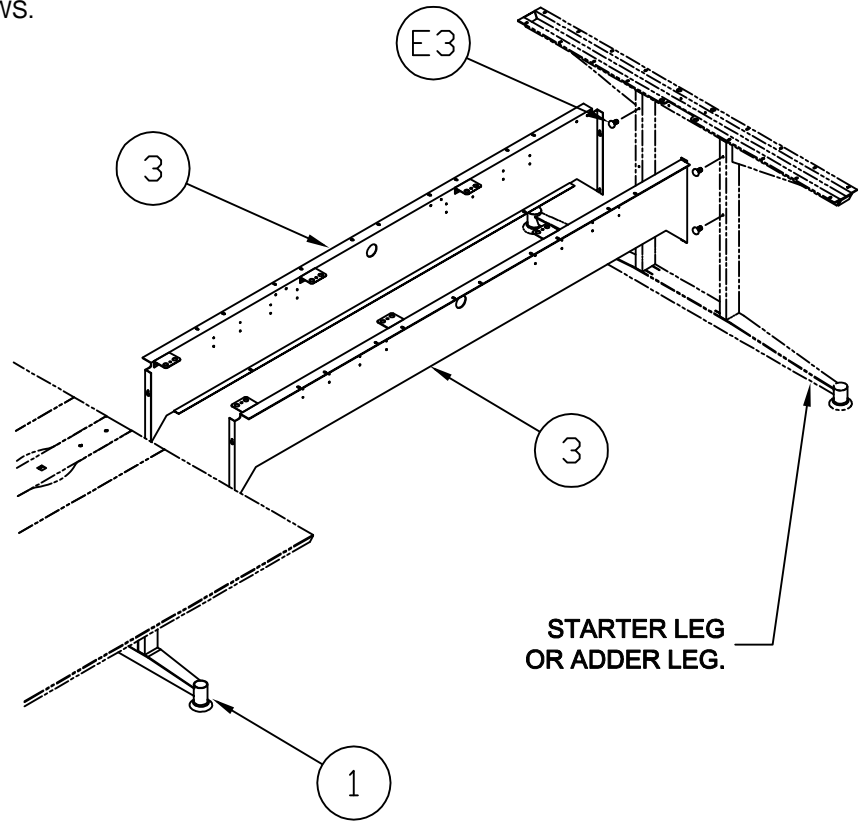

(3)

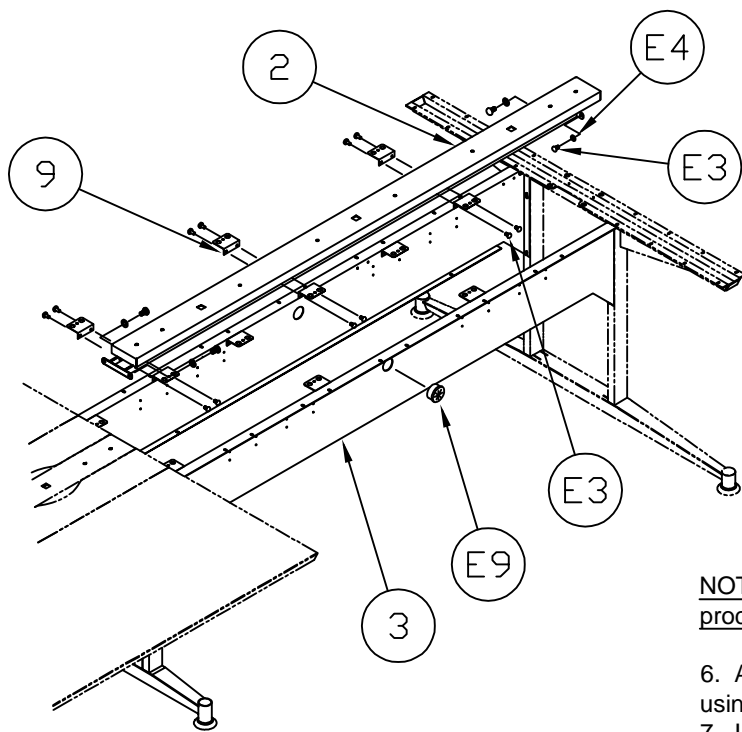

NOTE: If installing a table without access panels (6), proceed to Step 7.

6. Attach mounting angles (E12) to beam assembly (2) using screws (E13). Align with angles on trough sides.
7. Install beam (2) from above. Place beam (2) between legs (1) by tipping the beam (2) into the leg flange notch. Secure beam (2) with screws (E3) and washers (E4). Tighten all screws (E3) at this time.
8. Insert bushings (E9) into trough sides (3).

9. Lay pan (4) onto trough side flanges (3). Secure pan (4) to trough sides (3) using pine tree clips (E11)
10. Install slam latch (E8) into slot in inner leg panel (7) as shown.
11. Insert tabs in the bottom of inner leg panel (7) into slots in foot. Rotate inner leg panel (7) up so that slam latch catches flange on pan (4).
12. Insert square hole plugs (E7) and pine tree clips (E10) into holes in beam. **NOTE:** This step should be done after privacy panels or monitor posts are installed in the beam.

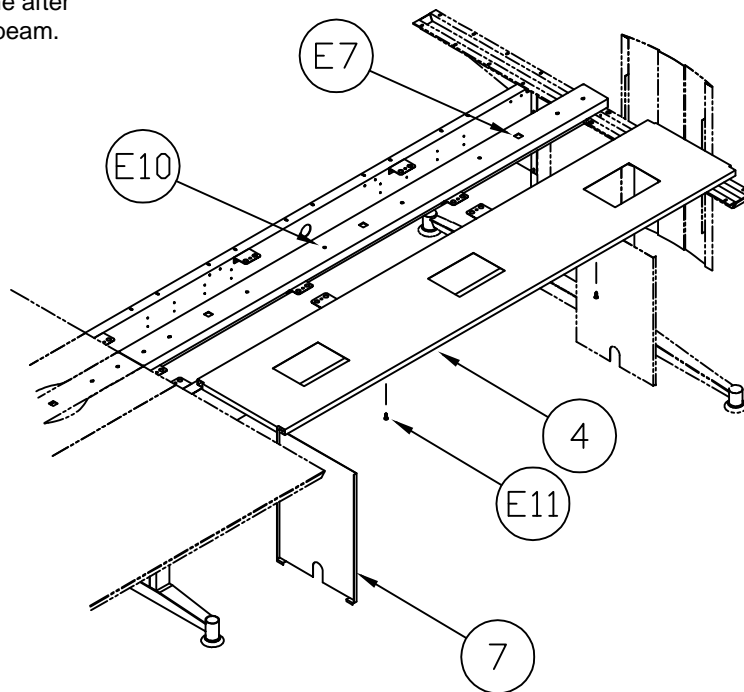
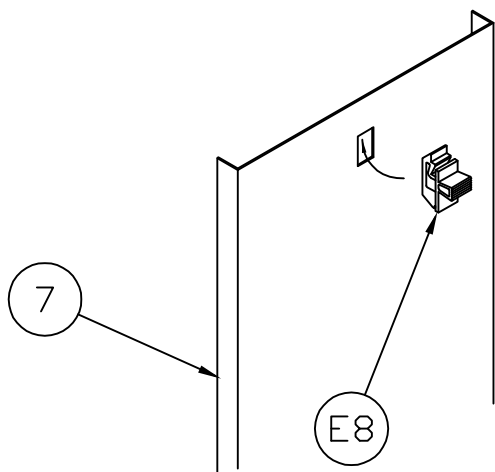

For tables "WITHOUT" Access Panels (6).

13. Position work surface (5) without access panels and secure with screws (E5).

For tables "WITH" Access Panels (6).

- 14. Insert dowels (E14) into holes in access panels (6) as shown below. NOTE: For 48" W tables use the positions shown in the far left and right of the view below.
- 15. Lay access panels (6) onto table frame so that dowels engage holes in mounting angle..
- 16. Insert spacers (E15) between access panels and work surfaces as shown (2 per access panel).
- 17. Position work surfaces and secure with screws (E5).
Remove spacers.

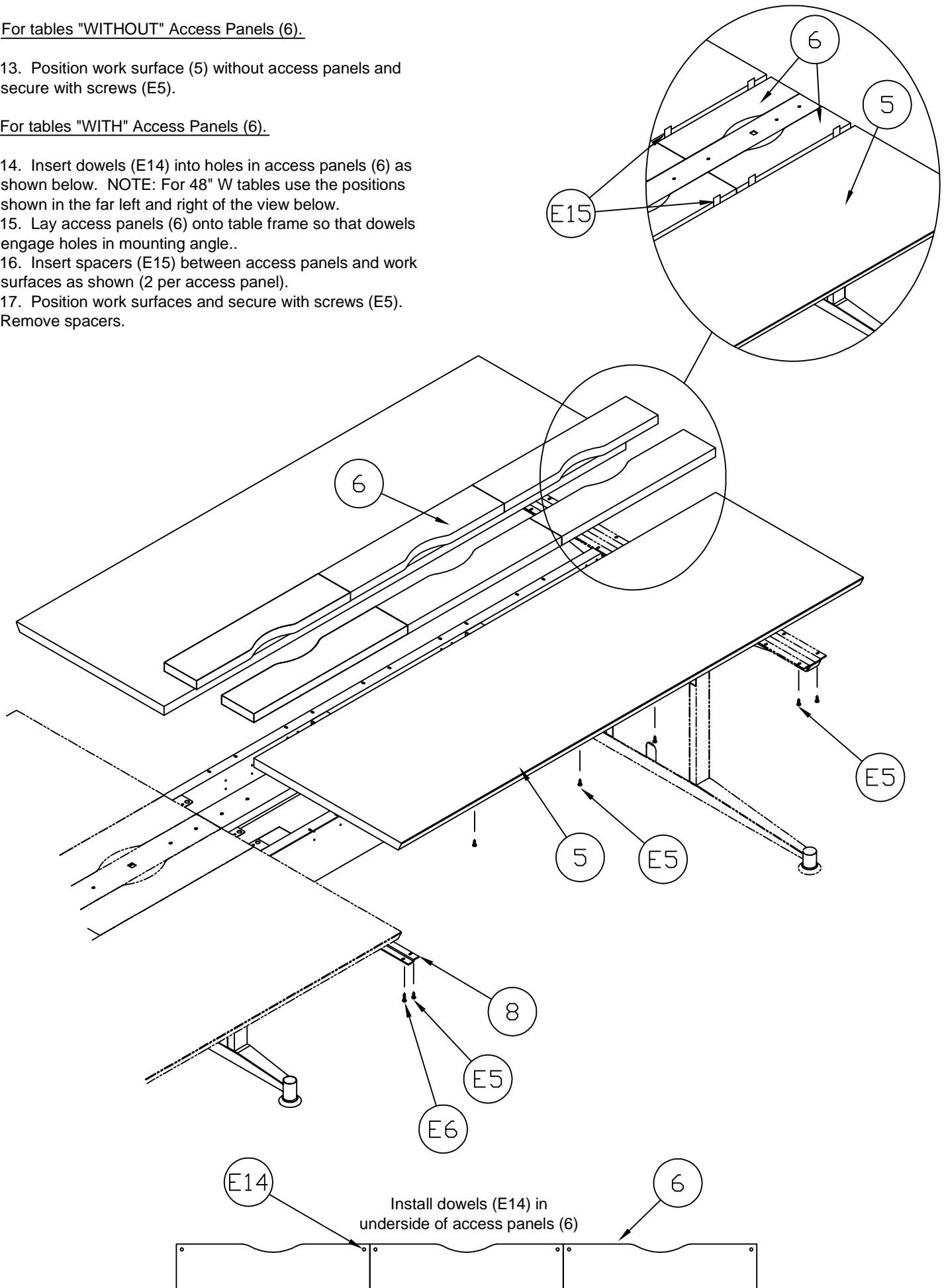

- 18. Remove screws (E5) from existing worksurface and install top joining angle (8) using screws (E6).
- 19. Position work surface (5) and secure using screws (E5).

