

# ASSEMBLY INSTRUCTIONS

## COHERE CONFERENCE TABLE A1 & A2

**NOTE:**

**PLEASE COUNT AND INSPECT ALL PIECES BEFORE DISPOSING OF ANY CARTON OR PACKING MATERIALS.**

When ordering components, specific color and/or size information may be required.  
Contact a Mayline Customer Service Representative. 1-800-822-8037

**COMPONENTS FOR A1 & A2 CONFIGURATION**

<u>REF#</u>	<u>QTY A1</u>	<u>QTY A2</u>	<u>DESCRIPTION</u>	<u>PART NO.</u>
1	1	1	Top	CALL ~**
2	2	2	Y-Leg Assembly	CALL ~**
3	0	1	Center Leg Assembly	CALL ~**
4	1	2	Bridge	CALL ~**

**HARDWARE BAG (Part No. DS250) per Y-Leg/Center Leg Assembly**

<u>REF#</u>	<u>QTY.</u>	<u>DESCRIPTION</u>
E1	8	Screw, #12 x 1" PHS

**HARDWARE BAG (Part No. DS163) per Bridge**

<u>REF#</u>	<u>QTY.</u>	<u>DESCRIPTION</u>
E2	2	Backer Plate
E3	2	Screw, 3/8-16 x 1.00

**Replacement Part not included in assembly**

<u>REF#</u>	<u>QTY</u>	<u>DESCRIPTION</u>	<u>PART NO.</u>
R1	1	Glide	DS131

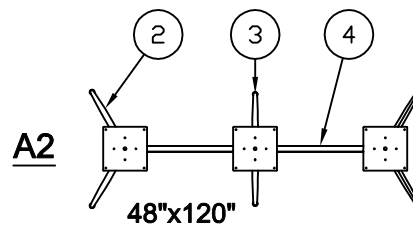
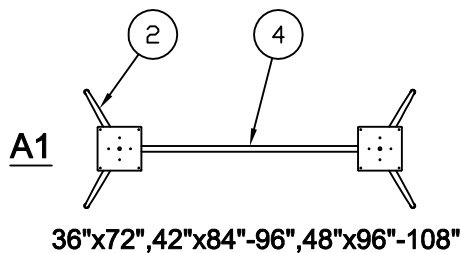

***Recommended tools for Assembly: 9/16 Open-end Wrench, #3 Phillips bit***

**A1 Configuration:**

1. Attach Y-Leg Assembly (2) to Bridge (4) using Backer Plate (E2) and Screw (E3). Repeat for each Bridge.

**A2 Configuration:**

2. Start with A1 above. Then attach Center Leg (3) to Bridge (4) using Backer Plate (E2) and Screw (E3). Repeat for each Bridge.

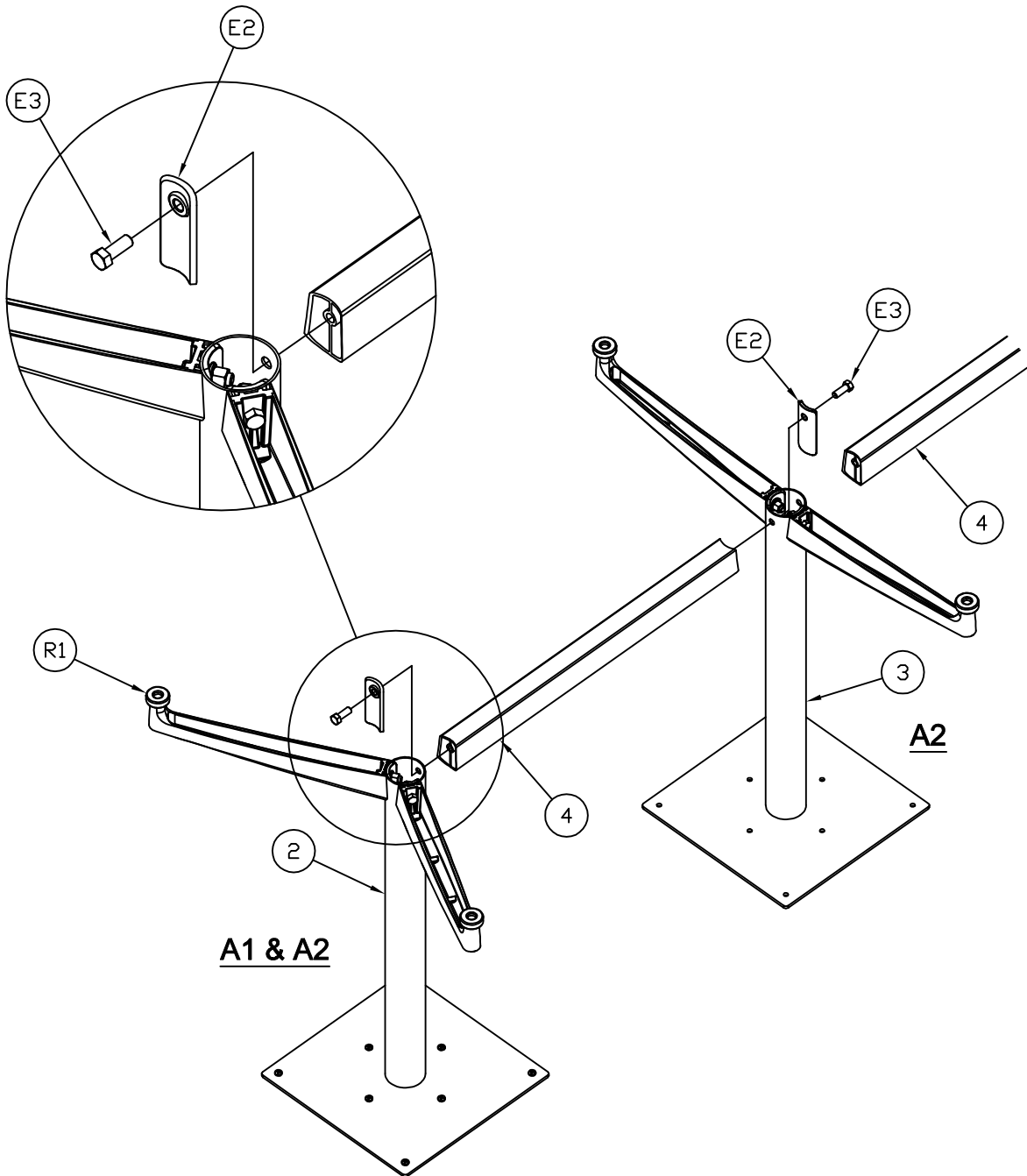

3. Place Base Assembly right side up and attach Top (1) using 8 Screws (E1) per Mounting Plate.

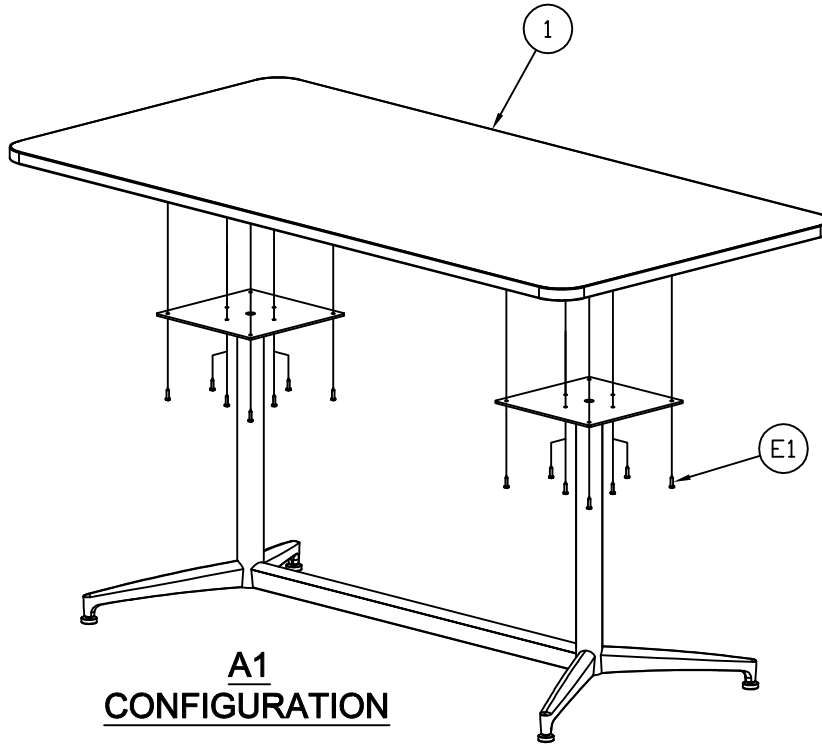

**A1**  
**CONFIGURATION**

**\*\*DO NOT\*\***  
ASSEMBLE UP-SIDE DOWN AND  
TRY TO FLIP TABLE .

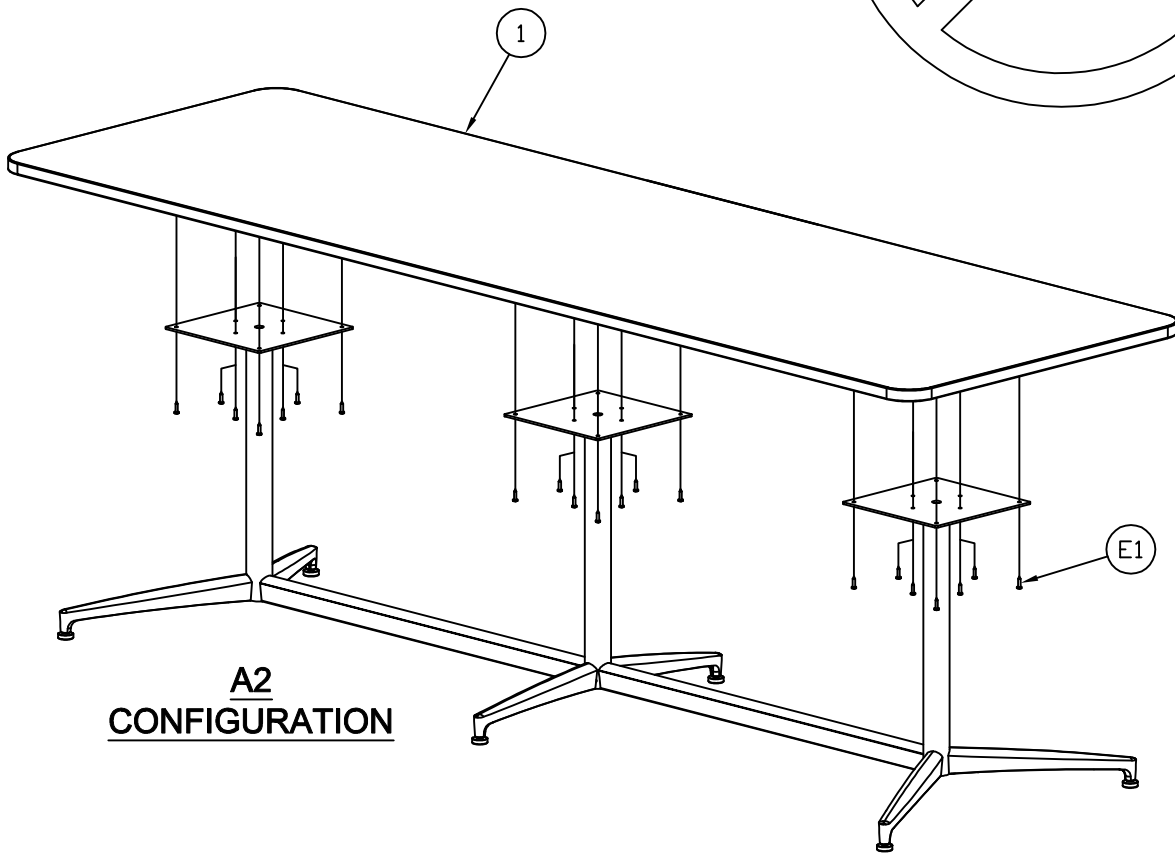
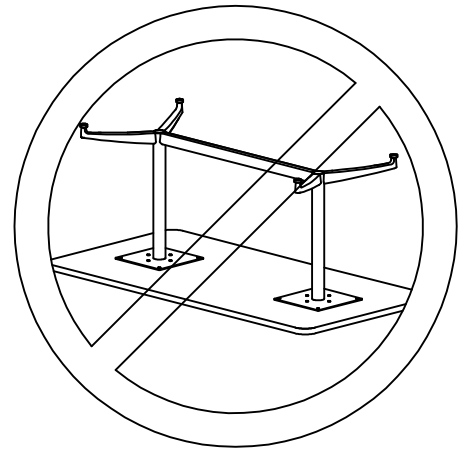

**A2**  
**CONFIGURATION**