

# ASSEMBLY INSTRUCTIONS

## COHERE CONFERENCE TABLE A3

**NOTE:**

**PLEASE COUNT AND INSPECT ALL PIECES BEFORE DISPOSING OF ANY CARTON OR PACKING MATERIALS.**

When ordering components, specific color and/or size information may be required.  
Contact a Mayline Customer Service Representative. 1-800-822-8037

**COMPONENTS FOR A1 & A2 CONFIGURATION**

| REF# | QTY. | DESCRIPTION           | PART NO. |
|------|------|-----------------------|----------|
| 1    | 1    | Top                   | CALL ~** |
| 2    | 2    | Y-Bridge Leg Assembly | CALL ~** |
| 3    | 2    | Bridge (A3)           | CALL ~** |

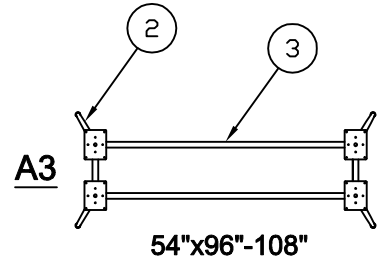

**HARDWARE BAG (Part No. DS242) per Y-Bridge Leg Assembly**

| REF# | QTY. | DESCRIPTION         |
|------|------|---------------------|
| E1   | 16   | Screw, #12 x 1" PHS |

**HARDWARE BAG (Part No. DS163) per Bridge**

| REF# | QTY. | DESCRIPTION          |
|------|------|----------------------|
| E2   | 2    | Backer Plate         |
| E3   | 2    | Screw, 3/8-16 x 1.00 |

*Recommended tools for Assembly*  
**9/16 Open-end Wrench, #3 Phillips bit**

**Replacement Part not included in assembly**

| REF# | QTY | DESCRIPTION | PART NO. |
|------|-----|-------------|----------|
| R1   | 1   | Glide       | DS131    |

**1. Attach Y-Bridge Leg Assembly (2) to Bridge (3) using Backer Plate (E2) and Screw (E3). Repeat for each Bridge.**

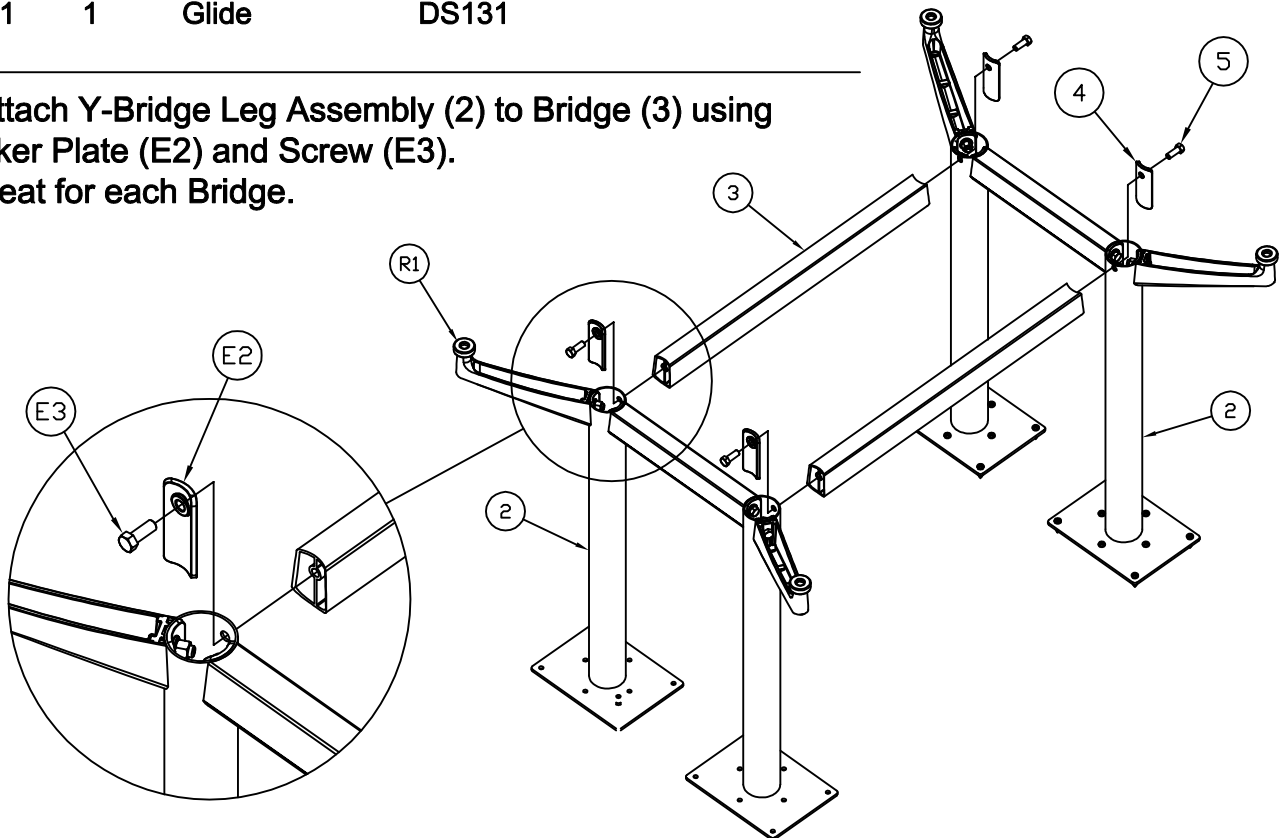

2. Place Base Assembly right side up and attach Top (1) using 8 Screws (E1) per Mounting Plate.

**DO NOT TIGHTEN SCREWS UNTIL ALL SCREWS HAVE BEEN STARTED.**

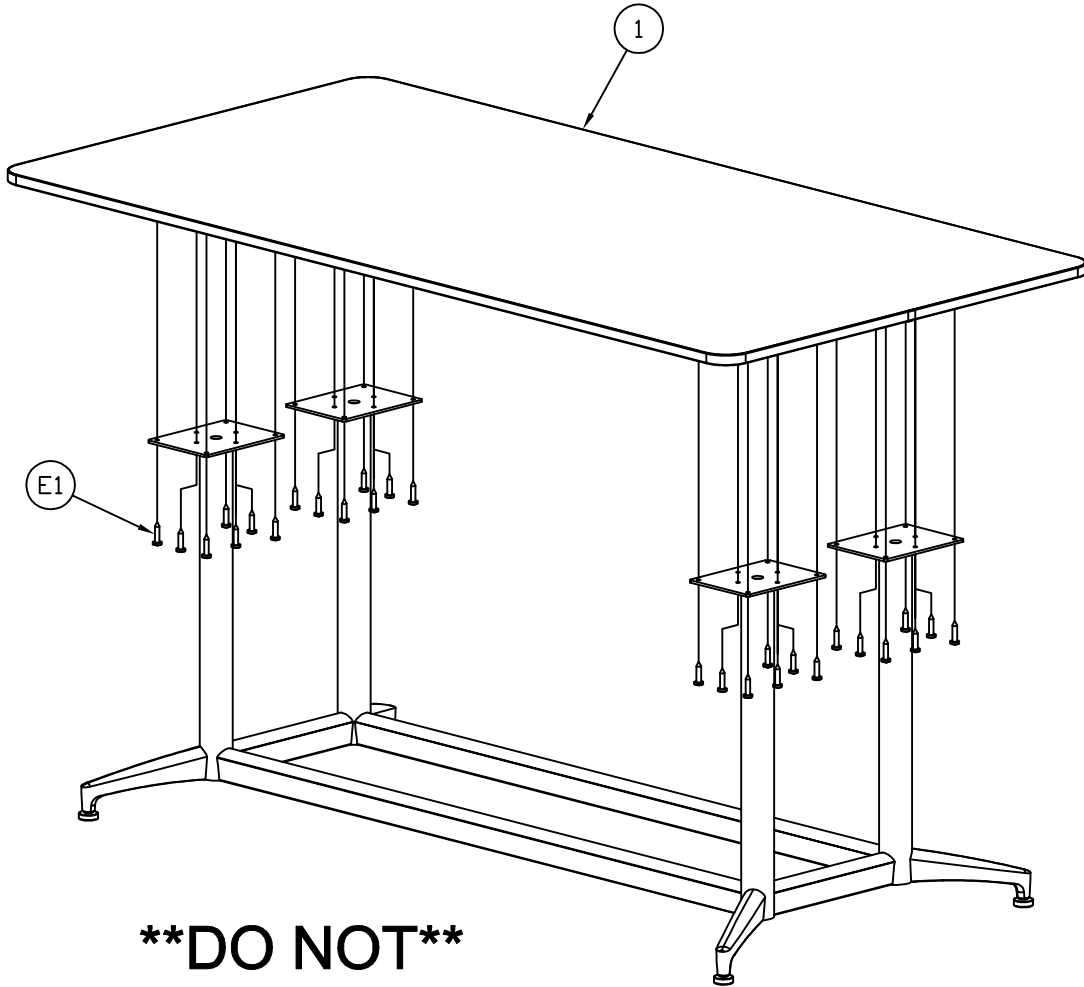

**\*\*DO NOT\*\***  
ASSEMBLE UP-SIDE DOWN AND  
TRY TO FLIP TABLE .

