

Kwik-File, LLC

Mailflow-To-Go™

TB30 Work Table

Work Table, 30"W x 30"D x 29" - 36"H

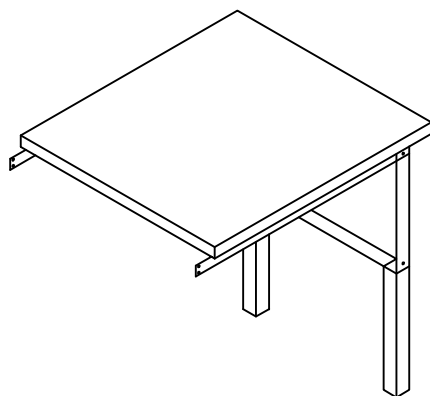



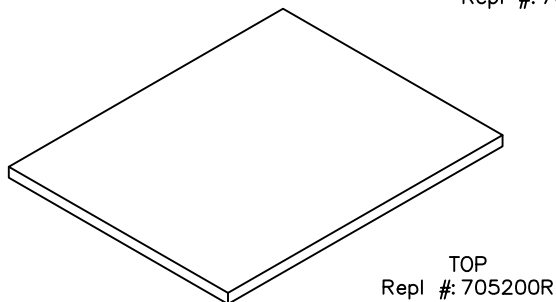
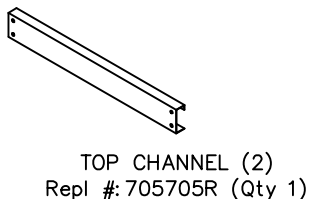
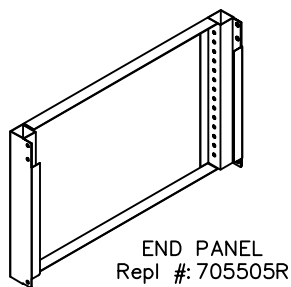



Parts list and drawings for TB30 Work Table.

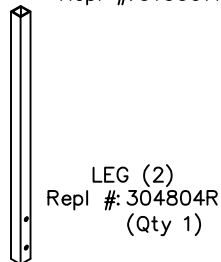

LEG GLIDE (2)
Repl #: 910080R

GLIDE INSERT (2)
Repl #: 910007R



 1/4-20 NUT (4)	 #8 x 1/2" TOP SCREW (8)
 1/4-20 PAINTED SCREW (4)	 LEG SCREW (4)
	
Hardware Bag Repl #: 705905PR	



Tools required: a blade screwdriver (allen wrench provided).

NOTE: The TB30 Work Table may be used only when connected to a TB60 Work Table, functioning either as a corner table to support the Corner Sorter, or as an extension work surface to the TB60 Work Table.

1. Unpack carton and identify all parts. Peel off protective film from the front face of all flat steel parts.
2. Place table top upside down (screw holes up) on a clean, flat, smooth surface.
3. Assemble end panel and front and back support rails; it's easiest to do this with these parts upside down on the table top. Bolt together front support rail, back support rail, and end panel against top. Be sure open flange of support rails faces inside with angled side against top. Use the four painted machine screws and kepsnuts (two for front support rail, two for back support rail).
4. Locate the assembled table frame so that the holes in the back support rails, and those in the end panel back panel line up with the pre drilled holes in the top. Insert the machine screws provided through the holes and tighten into the top. Additional top screws are self tapping and can be installed without pre-drilling.

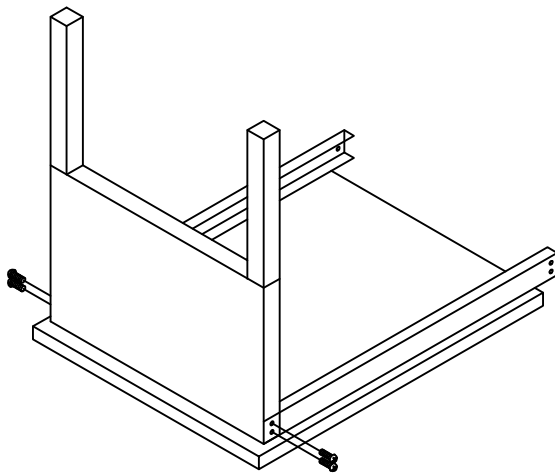

5. Using a hammer or rubber mallet, pound the glide insert into the leg. Then screw the leg glide into the glide insert. Place legs (two legs only; the adjacent TB60 Work Table provides support for the other side of the TB30 Work Table) into the leg sleeves at the front and back corners of the end panel. Each leg has two threaded holes at the upper end; legs should be inserted so that the holes line up with the adjustment holes in the leg socket. Table height can be adjusted between 29" and 36" in one inch increments.

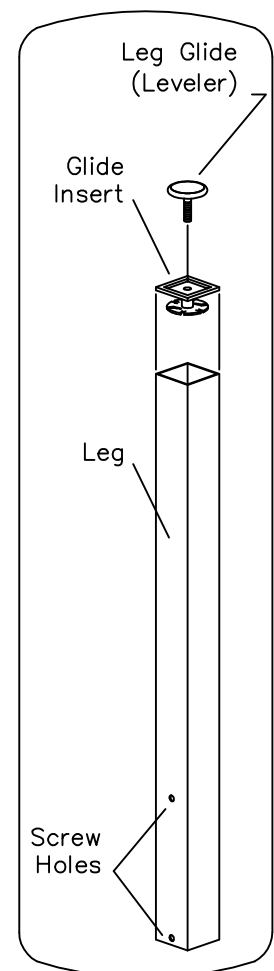

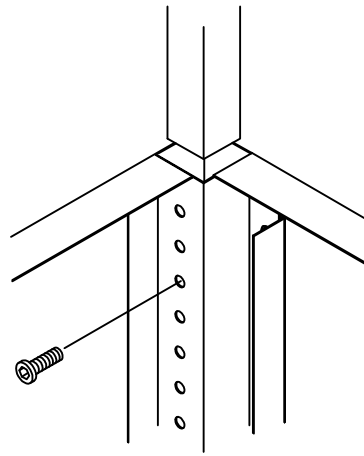
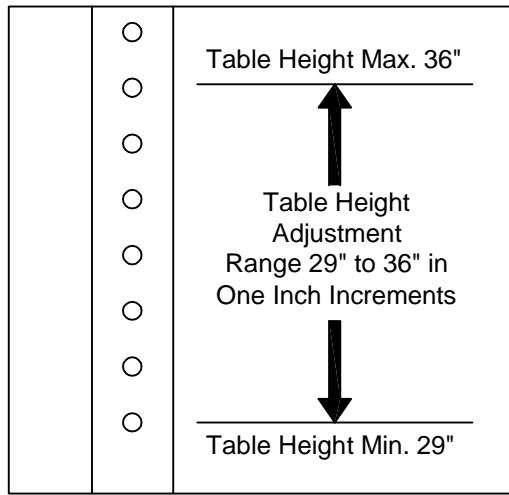

6. After deciding on table height (must be the same as adjacent TB60 Work Table), line up the threaded holes in each leg with the proper holes in the leg sleeve; use two socket-head screws to assemble each leg in place (allen wrench provided)

7. Once both legs have been assembled in place, carefully set table upright adjacent to TB60 Work Table and connect front and back support rails to the TB60 Work Table. Use the four painted machine screws and kepsnuts now holding one side of the TB60's front support rail and back panel in place.

8. Each leg has an adjustable glide. If the table needs to be leveled, turn the glide as needed to shorten or lengthen either leg.